

# PRODUCT TECHNICAL DATASHEET

# BI/008

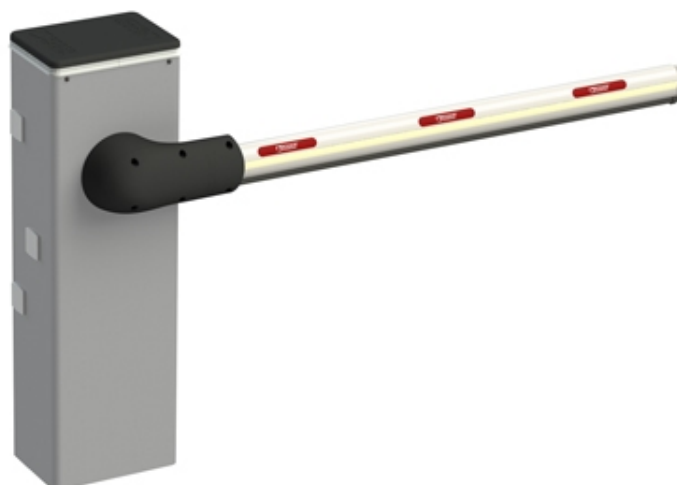

CODICE	DESCRIZIONE	PZ/PALLET
BI/008	Automatic Barrier Brushless 36V DC super intensive use up to 8 meters, with operator and and built-in digital control panel and absolute encoder on board.	4

## SPECIFICHE TECNICHE PRODOTTO

Barriers	Up to 8 mt long
Power line supply	230V AC - 50Hz
Motor power supply	36V DC
Electrical absorption	max 18A
Power rating	300W
Frequency of use	Super intensive use
Torque	10 - 400 N m
Operating temperature	- 20 + 55 C°
Protection level	IP54
Reductor Type	Irreversible
Opening time at 90°	9 ÷ 29 (sec)
Onboard control unit	CTRL Digital Controller 36V DC
Encoder	Digital native encoder + magnetic digital SENSORED, 4096 PPR
Accessories power supply	24V DC
Release system	European Key cylinder
Batteries recovery	Available (optional)
BUS synchronization Master/Slave	Yes
Operating cycles per day (opening/closing - 24 hours no stop)	2500 cycles
Maximum dimension product in mm (L x W x H)	500 x 270 x 1237

Product weight packed (Kg)	95
Number items per pallet	4

# DIMENSIONI

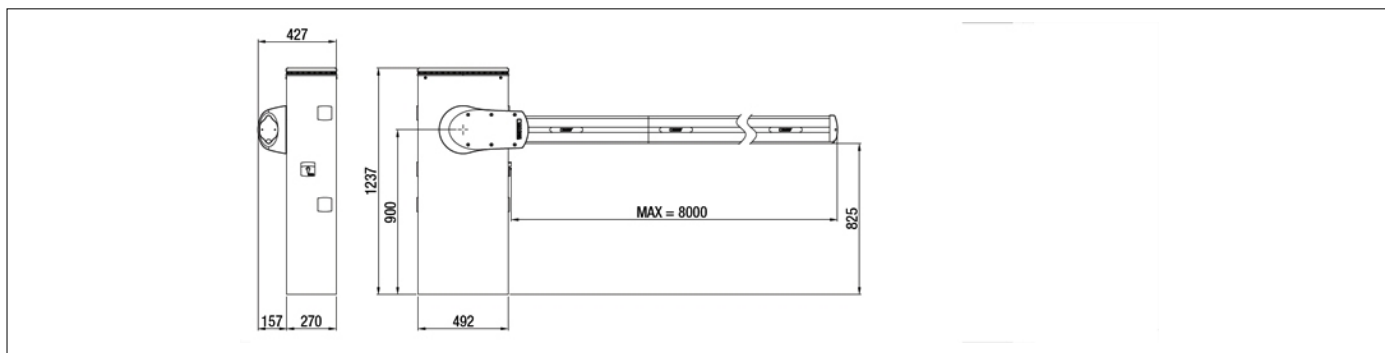

DIMENSIONS

# PRODOTTI ACCESSORI

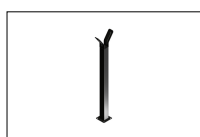

**BAFS/01**  
Fixed support for bars.



**BAFS/02**  
Fixing support, adjustable.

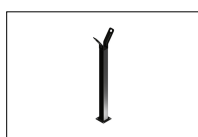

**BAFS/03**  
Fixing support with bolt predisposition for bars.

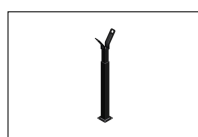

**BAFS/04**  
Fixing support adjustable, with bolt predisposition for bars.



**BAFS/05**  
Adjustable fixed end rest for barriers of the ranges with magnetic suction cup.

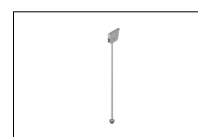

**BAMS/01**  
Mobile support for bars.

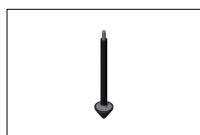

**BAMS/01/EXT**  
Extension 20cm for mobile support BAMS/01.



**BA/128/4**  
White painted aluminum rod, 4 meters long, with LED cover profile and impact resisteng rubber profile.

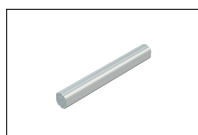

**JNT/BA/128**  
Internal boom bar joint in anodized aluminum including fixing screws for bars BA/128.

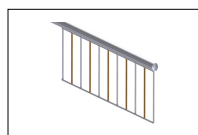

**BARK/02**  
Barrier skirting in aluminum, with stainless steel screws mounted on bronze bushings. Single module of length 2 meters.

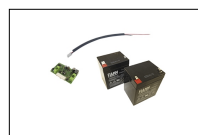

**BI/BAT/KIT**  
Kit for emergency batteries charger for brushless digital controller CTRL 36V DC with plug-in card, with 2 recovery batteries 12V DC, 4.5 Ah. Kit for BIONIK barrier.



**BI/BCHP**  
Plug-in card, batteries charger, for brushless digital controller CTRL 36V DC, without recovery batteries, for BIONIK barrier.



**BT12V45**  
Pair of batteries 12V 4.5 Ah.

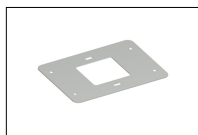

**KT244**  
Fixing plate with stay bolts and screws for BI/008.



**CRA/BAR**  
Post for photocells G90/F2ES - G90/F4ES - for spaced installation on a barrier cabinet (+23cm).



**B73/EXP**  
Signal status board, 2 output for CTRL - CTRL/P



**SP/85/AS/02**  
Assembly 2 spring diameter 85 mm for barriers.



**DLD1/24**  
Loop detector for 1 loop, 2 output, 24V AC/DC.



**DLD2/24**  
Loop detector for 2 loop, 2 output + output alarm, 24V AC/DC.

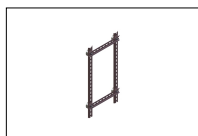

**KT239**  
Kit DIN rail with magnetic support.



**KT242**  
Cable passage kit, with magnetic support, for barriers.



**ALED/8C**  
Luminous led cord of 8 meters with connection cable for boom arms.



**R99/BASB20**  
Pack of 20 stickers for barrier.



**R99/BASB40**  
Pack of 40 stickers for barrier.