

PRODUCT TECHNICAL DATASHEET

R30/1204



CODICE	DESCRIZIONE	PZ/PALLET
R30/1204	Electromechanical motor 230V AC irreversible ideal for sliding gates up to 1200 Kg. with built-in control unit H70, optical encoder and magnetic limit switch.	44

SPECIFICHE TECNICHE PRODOTTO

Max gate weight	1200 kg
Power line supply	230V AC - 50Hz
Motor power supply	230V AC
Power rating	420W
Frequency of use	50%
Thrust	800N
Operating temperature	-20+55°C
Protection level	IP43
Reductor Type	Irreversible
Manoeuvre speed	9.5 m/min (0.16 m/s)
Motor thermal protection	150°C
Incorporated condenser	18 µF
Limit switch	Magnetic
Onboard control unit	H70/104AC
Encoder	Optical
Type exit gear	Z17/mod 4
Maximum dimension product in mm (L x W x H)	325 x 162 x 295
Product weight packed (Kg)	16,7
Number items per pallet	44

DIMENSIONI

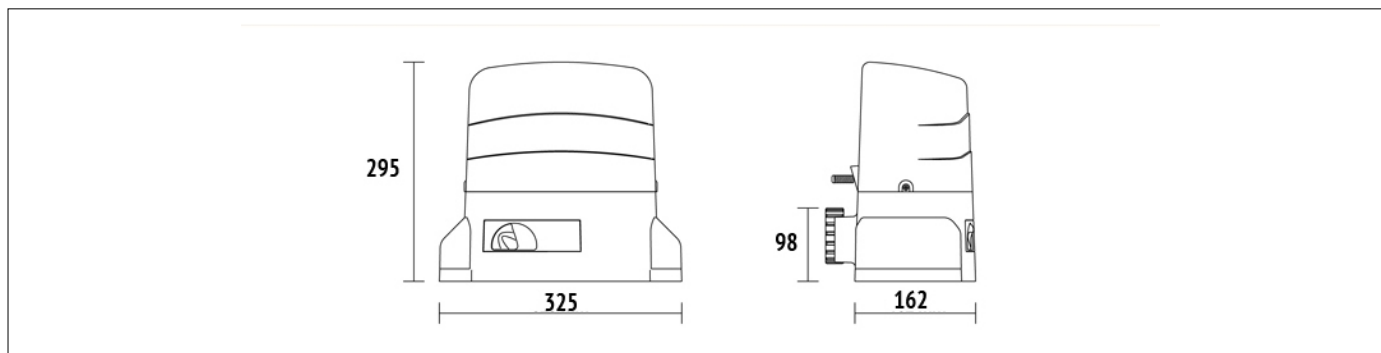

DIMENSION

PREDISPOSIZIONI INSTALLAZIONE STANDARD

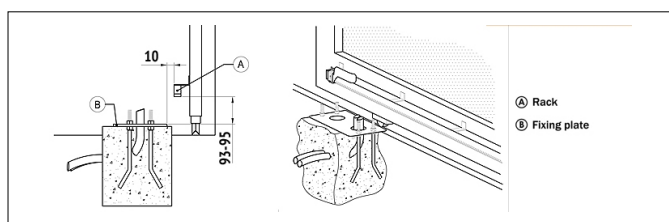

PREDISPOSITION FOR STANDARD INSTALLATION

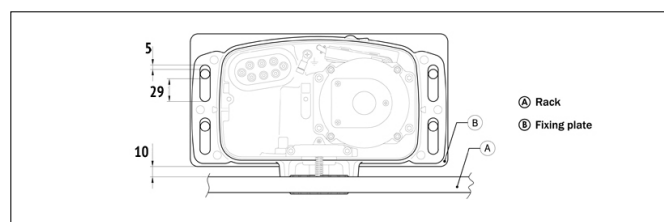

PREDISPOSITION FOR STANDARD INSTALLATION

PRODOTTI ACCESSORI

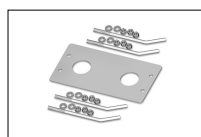

KT210
Fixing plate with stay bolts and screws for R30 series.

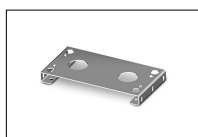

KT212
Raised fixing plate for R30 series (+3,5 cm).

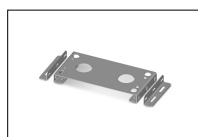

KT213
Fixing plate and angles bars kit for R30 series.



GA550
Galvanised steel rack 22x22x1000 module 4.

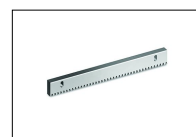

GA551
Galvanised steel rack 30x12x1000 module 4 with spacers and screws.



GA554
Pocket of 6 spacers (2,5 cm) and screws.

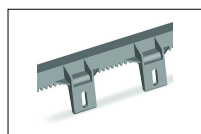

GA553
Nylon rack module 4 with 6 connectors L.1000.

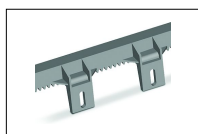

GA557
Roger Technology nylon rack module 4 with 6 connectors L.1000.

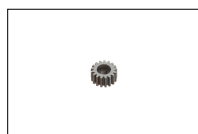

LT328
Z17 mod. 4 Pinion with increased thickness H.38 for series R30 - G30 - E30

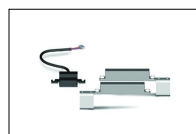

MC775
Kit magnetic limit switch for control unit H70/103AC, H70/104AC, B70/1DC, B70/1DCHP.



R99/C/001
Signboard Automatic Opening®.