



# RI.6E

## AUTOMATIONS FOR sliding gates up to 600 kg

- Self-locking electromechanical operator, suitable for residential use
- All the versions are equipped with control panel and pre-wired limit switches.
- Reduction unit submerged in oil



**control unit included**



The high quality of the components assures a long life of the product and a silent movement.



Easy to use unlock device



Pull-out terminals in order to make the installation easier and faster.

### TECHNICAL DATA

### RI.6E

Power supply	230 Vac
Motor supply	230 Vac
Absorbed Power	280 W
Max. absorbed current	1,6 A
Torque	36 Nm
Opening speed	8,48 r.p.m.
Operation cycle	40 %
Protection level	IP 54
Operating Temp.	-20°C/+70°C
Lubrication	oil
Max gate weight	600 Kg
Weight	13 Kg

# RI.624N



## AUTOMATIONS FOR **sliding gates** up to 600 Kg

- 24Vdc self-locking electromechanical operator for intensive use
- Amperometric anticrushing control
- Easy electrical connections thanks to the plug in terminals.
- The 24Vdc version includes the battery charger for the automatic use of the automation in case of power failure. It needs DA.BT2 batteries.



**intensive use  
control unit included**

### TECHNICAL DATA **RI.624N**

Power supply	230 Vac
Motor supply	24 Vdc
Absorbed Power	120 W
Max. absorbed current	6 A
Torque	20 Nm
Opening speed	9 r.p.m.
Operation cycle	intensive use
Protection level	IP 54
Operating Temp.	-20°C/+70°C
Lubrication	oil
Max gate weight	600 Kg
Weight	13 Kg



BRAIN24 control unit built-in



The 24Vdc version includes the battery charger for the automatic use of the automation in case of power failure.



The high quality of the raw materials assures a long life of the product and a silent movement.



## RI.1NA

- 1 RI.6E Operator with control unit
- 1 FTM.S Pair of photocells
- 2 T2WV Transmitters
- 1 RR.1WV receiver
- 1 LAMP1 Flashing light with built-in aerial
- 1 CH Key selectors
- 1 KE External box for key selectors
- 1 ID.TA Warning board



## RI.2NA

- 1 RI.624N 24Vdc Operator with control unit and built-in receiver
- 1 FTM.S Pair of photocells
- 2 T2WV Transmitters
- 1 LAMP124C 24 Vdc Flashing light with built-in aerial
- 1 CH Key selectors
- 1 KE External box for key selectors
- 1 ID.TA Warning board

## INSTALLATION DRAWING

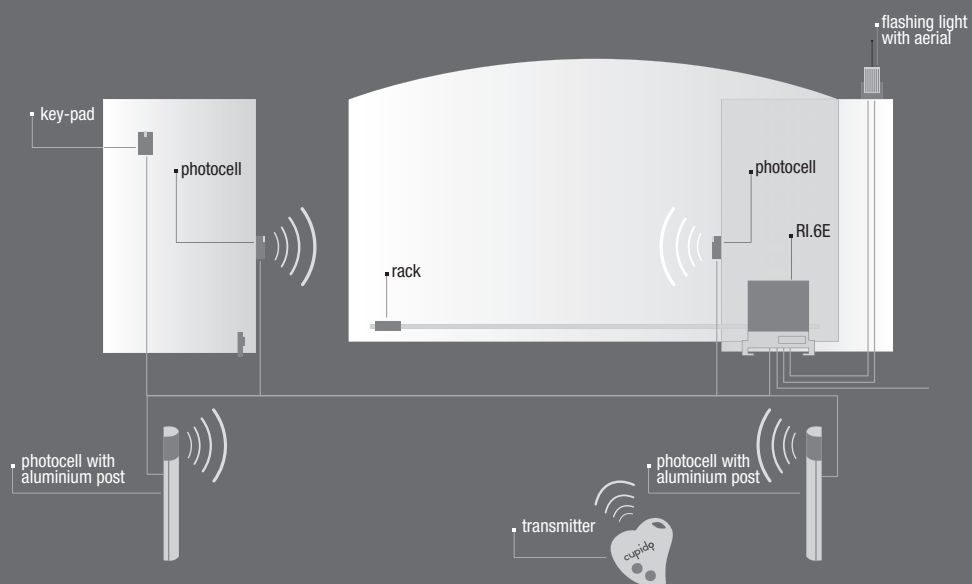

## DIMENSIONS

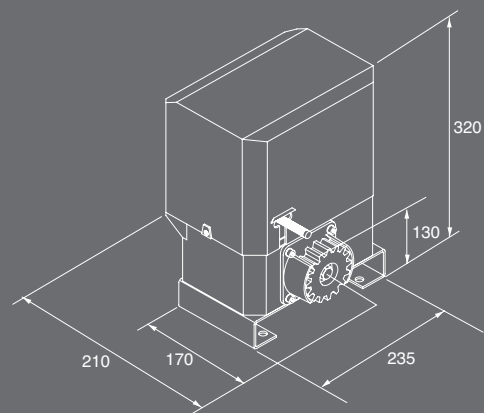

## SUGGESTED ACCESSORIES

**DA.2S**



Electronic module which allows the synchronized movement of two gates

**LB**



Standard box for control units.  
Protection level IP 55

**DA.BT6**  
**DA.BT2**



DA.BT6: Battery 6Ah 12 VDC  
DA.BT2: Battery 2.1Ah 12 VDC  
Only the batteries DA.BT2 can be placed into the operator.

**RI.M4Z**



M4 galvanized rack  
(22x22x2000 mm)

**RI.M4P**



M4 Nylon rack, provided with slots and screws  
(28x40x1000 mm)

**RI.M4F**



M4 galvanized rack with slots and screws  
(30x12x1000 mm)

**RI.SF**



Outdoor wire unlock system for gates without pedestrian entrance.

**ID.TA**



Aluminium warning board