

# Saloon

## Motorised swing turnstiles



## The ideal solution for selecting shopping cart transit

- This turnstile stands out thanks to its elegance, quality and silent operation.
- Ideal for installing in prestigious settings such as hotels, showrooms and beauty centers.
- It even comes in the double version to manage those wider passages.
- Can be coupled with modular barriers to complete installations and perfectly integrates with all Came access control systems.
- RAL 7035 enamel finish.

### Dimensions (mm)

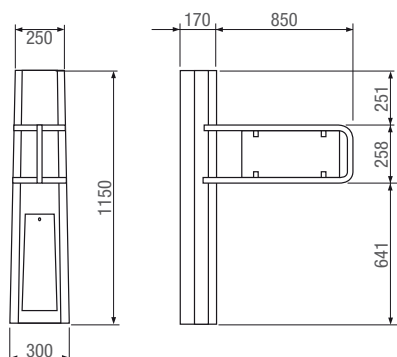

### Application (mm)

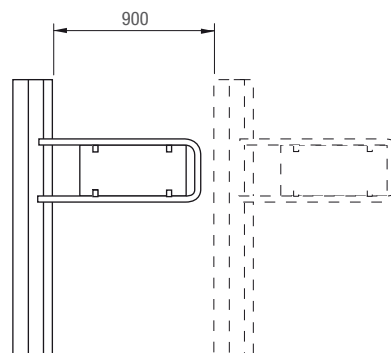
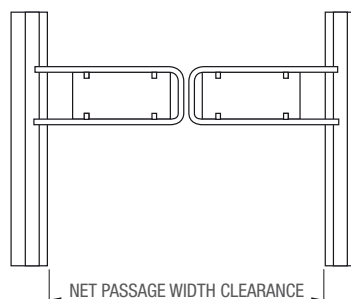

### Technical features

Type	PSEP0S00 - PSEPSS00
Power supply (V)	230 AC
Operating power (V)	24 DC
Current draw (A)	2.5
Weight (Kg)	40
Operating temperature (°C/°F)	-20 ÷ +55/-4 ÷ +131

# The complete range



Code	Description
<b>24 V DC motorised swing turnstiles</b>	
001PSEPOS00	Motorised bi-directional swing turnstile made of galvanised steel with RAL 7035 varnish finish complete with control board and push-to-open antipanic system. Leaf width L = 850 mm / 33.46 in.
001PSEPS00	Motorised bi-directional swing turnstile made of AISI 304 steel complete with control board and push-to-open antipanic system. Leaf width L = 850 mm / 33.46 in.
<b>MANDATORY accessories</b>	
001PSOPAL01	24 V DC 2.5 A switching power unit complete with IP65 casing for one turnstile.
001PSOPAL06	24 V DC 6.5 A switching power unit complete with IP65 casing for two turnstiles.
001PSMCECH	Synchro card for double passage openings.
<b>Accessories</b>	
001PSOPSF01	Bi-directional traffic light with high-luminosity LED.
001PSEPTRF	Barrier composed of: - n. 1 vertical element with built-in photocell, made of AISI 304 steel, fastening flange in galvanised steel and flange cover in chromed plastic - n. 2 horizontal elements measuring L = 1,000 mm / 39.37 in - n. 4 chromed plastic sleeves.
001PSEPTRFX	Barrier composed of: - n. 1 vertical element, AISI 304 steel fastening flange and flange cover, with built-in photocell. - n. 2 horizontal elements measuring L = 1,000 mm / 39.37 in - n. 4 AISI 304 steel sleeves with glossy finish.
001PSCSCR04	Console for remotely controlling up to max 4 access-ways.
<b>Customised treatments</b>	
001PSMLANT	Extra charge for changing width of leaf (MIN = 500 mm / 19.68 in - MAX = 1,000 mm / 39.37 in).



## NOTE

001PSMLANT Specify the custom width of the leaf (MIN = 500 mm - MAX = 1,000 mm).

001PSMCECH For synchronized opening of double access-ways it is necessary to order one synchronization card for each turnstile.