



IS194 Rev.01 05/11/2019

# BIONIK8

**Barriera automatica Brushless**  
**Automatic barrier Brushless**  
**Automatisierung für Schranke Brushless**  
**Barrière automatique Brushless**  
**Barrera automática Brushless**  
**Barreira automática Brushless**



**IT - Manuale di installazione**

**EN - Instruction and warnings for the installer**

**DE - Anleitungen und Hinweise für den Installateur**

**FR - Instructions et avertissements pour l'installateur**

**ES - Instrucciones y advertencias para el instalador**

**PT - Instruções e avisos para o instalador**

# 1 GENERAL SAFETY PRECAUTIONS



## **Failure to respect the information given in this manual may cause personal injury or damage to the device.**

This installation manual is intended for qualified personnel only.

ROGER TECHNOLOGY cannot be held responsible for any damage or injury due to improper use or any use other than the intended usage indicated in this manual.

Installation, electrical connections and adjustments must be performed by qualified personnel, in accordance with best practices and in compliance with applicable regulations.

Read the instructions carefully before installing the product. Bad installation could be dangerous.

Before installing the product, make sure it is in perfect condition: if in doubt, do not use the equipment and contact qualified personnel only.

Do not install the product in explosive areas and atmospheres: the presence of inflammable gas or fumes represents a serious safety hazard.

Before installing the motorisation device, make all the necessary structural modifications to create safety clearance and to guard or isolate all the crushing, shearing, trapping and general hazardous areas.

Make sure the existing structure is up to standard in terms of strength and stability.

ROGER TECHNOLOGY is not responsible for failure to observe Good Working Methods when building the frames to be motorised, or for any deformation during use.

The safety devices (photocells, safety edges, emergency stops, etc.) must be installed taking into account: applicable laws and directives, Good Working Methods, installation premises, system operating logic and the forces developed by the motorised door or gate.

The safety devices must protect against crushing, cutting, trapping and general danger areas of the motorised door or gate.

The European standards EN 12453 and EN 12445 define the minimum safety requirements for the operation of automatic doors and gates. In particular, these standards require the use of force limiting and safety devices (sensing ground plates, photocell barriers, operator detection function etc.) intended to detect persons or objects in the operating area and prevent collisions in all circumstances.

Where the safety of the installation is based on an impact force limiting system, it is necessary to verify that the characteristics and performance of the automation system are compliant with the requisites of applicable standards and legislation.

The installer is required to measure impact forces and programme the control unit with appropriate speed and torque values to ensure that the door or gate remains within the limits defined by the standards EN 12453 and EN 12445.

ROGER TECHNOLOGY declines all responsibility if component parts not compatible with safe and correct operation are fitted.

Display the signs required by law to identify hazardous areas.

Each installation must bear a visible indication of the data identifying the motorised door or gate.

An omnipolar disconnection switch with a contact opening distance of at least 3mm must be fitted on the mains supply.

Make sure that upline from the mains power supply there is a residual current circuit breaker that trips at no more than 0.03A and overcurrent cutout upstream of the electrical system in accordance with best practices and in compliance with applicable regulations.

When requested, connect the automation to an effective earthing system (⊕) that complies with current safety standards.

During installation, maintenance and repair operations, cut off the power supply before opening the cover to access the electrical parts.

The electronic parts must be handled using earthed antistatic conductive arms.

Only use original spare parts for repairing or replacing products.

The installer must supply all information concerning the automatic, manual and emergency operation of the motorised door or gate, and must provide the user with the operating instructions.

The packaging materials (plastic, polystyrene, etc.) should not be discarded in the environment or left within reach of children, as they are a potential source of danger.

Dispose of and recycle the packing components in accordance with the standards in force.

These instructions must be kept and forwarded to all possible future user of the system.

## 2 DECLARATION OF CONFORMITY

I the undersigned, as acting legal representative of the manufacturer:

Roger Technology - Via Botticelli 8, 31021 Bonisiolo di Mogliano V.to (TV)

hereby DECLARE that the appliance described hereafter:

Description: Automatic barrier

Model: BIONIK8 series

Is conformant with the legal requisites of the following directives:

- Directive 2006/42/EC (Machinery Directive) and subsequent amendments;
- Directive 2011/65/EC (RoHS Directive) and subsequent amendments;
- Directive 2014/35/EU (Low Voltage Directive) and subsequent amendments;
- Directive 89/106/CEE (CPD Directive) and subsequent amendments;

and that all the standards and/or technical requirements indicated as follows have been applied:

EN 61000-6-3

EN 61000-6-2

EN 13241-1

Last two figures of year in which marking was applied **CE** 18.

Place: Mogliano V.to

Date 01/10/2018

Signature

## 3 INTENDED USE

The BIONIK automated barrier is specifically conceived for installations in private or public car parks, in residential, commercial or industrial areas or in high traffic zones.

This product may only be used for its expressly intended purpose. Any other usage is prohibited.

ROGER TECHNOLOGY cannot be held directly or indirectly responsible for any damage resulting from incorrect, inappropriate or unreasonable usage of this product.

## 4 LIMITATIONS USE

BIONIK8 barriers are suitable for VERY HEAVY DUTY operation and may be used with booms up to 8 metres in length.

## 5 DESCRIPTION OF THE PRODUCT

<b>BI/008</b>	BIONIK BRUSHLESS 36V DC Barrier for bars up to 8 metres, with on-board control unit, digital absolute encoder, complete with fixing base with tie rods and screws, and boom fixing flange.
<b>BI/008/115</b>	BIONIK BRUSHLESS 36V DC Barrier for bars up to 8 metres, with on-board control unit, digital absolute encoder, complete with fixing base with tie rods and screws, and boom fixing flange. For line voltages of 115V.

## 6 STANDARD DIMENSIONS

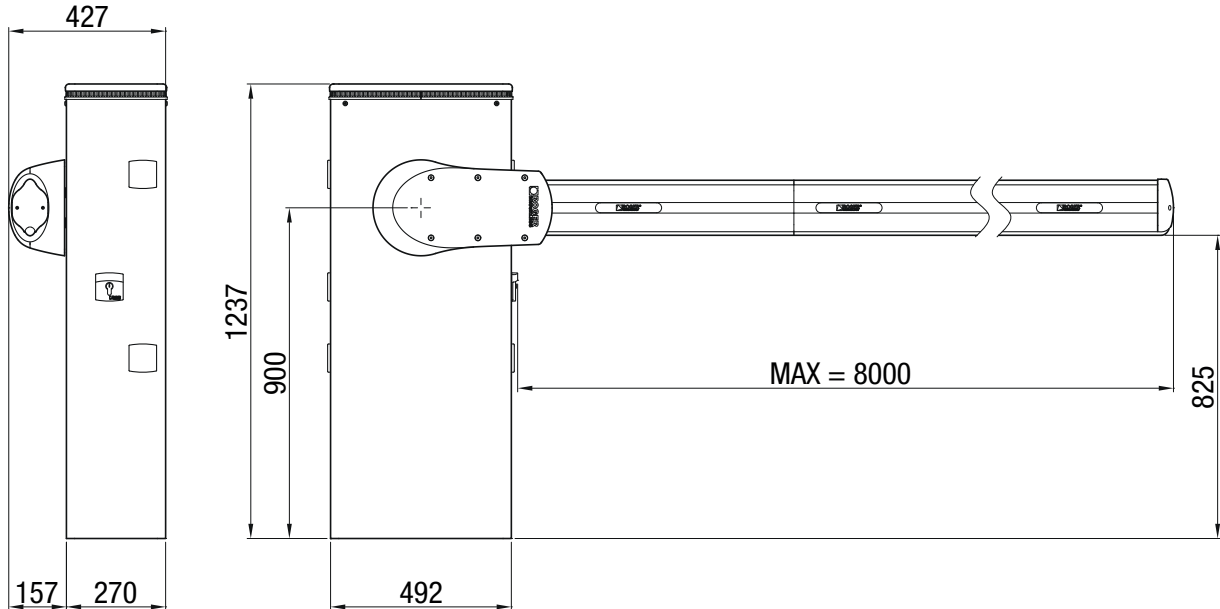

**i** All measurements are expressed in mm unless otherwise indicated.

## 7 PACKAGE CONTENT

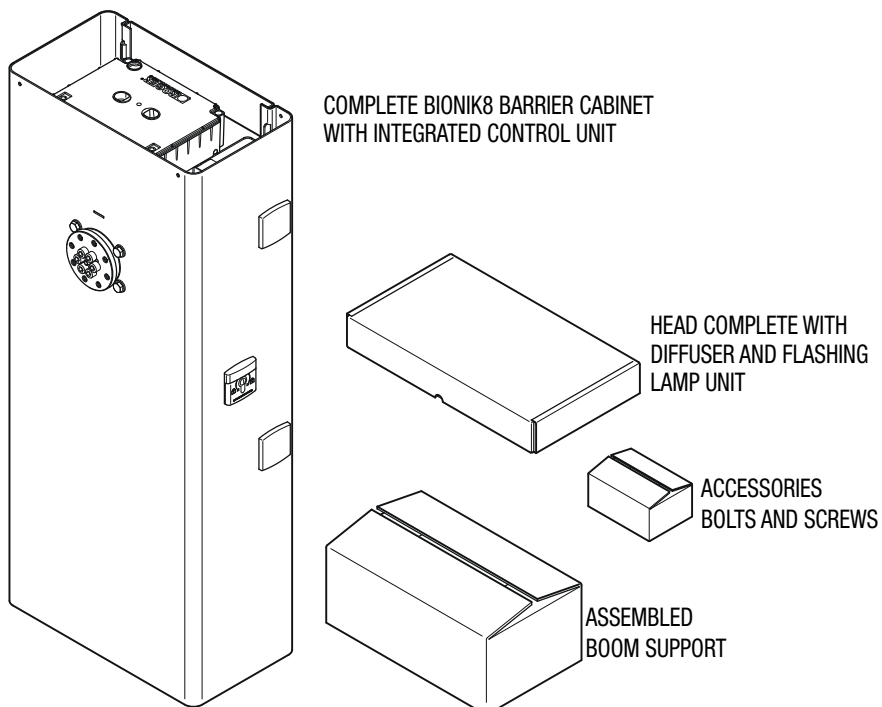

## 8 TECHNICAL CHARACTERISTICS

	BI/008	BI/008/115
POWER SUPPLY	230 Vac - 50 Hz ±10%	115 Vac 60 Hz ±10%
MOTOR POWER SUPPLY	0 ÷ 36 Vdc	0 ÷ 36 Vdc
POWER CONSUMPTION	0 ÷ 18 A	0 ÷ 18 A
POWER MOTOR	300 W	300 W
TORQUE	10 ÷ 400 Nm	10 ÷ 400 Nm
OPEN / CLOSE TIME 90 °	9 ÷ 29 sec	9 ÷ 29 sec
CONTROL SYSTEM	ABSOLUTE DIGITAL ENCODER	ABSOLUTE DIGITAL ENCODER
USE FREQUENCY	VERY HEAVY DUTY	VERY HEAVY DUTY
OPERATING CYCLES PER DAY (OPENING/CLOSING - 24 HOURS NO STOP)	2500	2500
GRADE OF PROTECTION	IP54	IP54
OPERATING TEMPERATURE	-20°C  +55°C	-20°C  +55°C
CONTROL UNIT (INTEGRATED) 36 Vdc	CTRL	CTRL
ACCESSORIES POWER SUPPLY	24 Vdc	24 Vdc
BOOM	up to 8 m	up to 8 m
EMERGENCY BATTERY	AVAILABLE (OPTIONAL)	AVAILABLE (OPTIONAL)
RELEASE SYSTEM	KEY WITH DIN CYLINDER	KEY WITH DIN CYLINDER

## 9 TYPICAL INSTALLATION

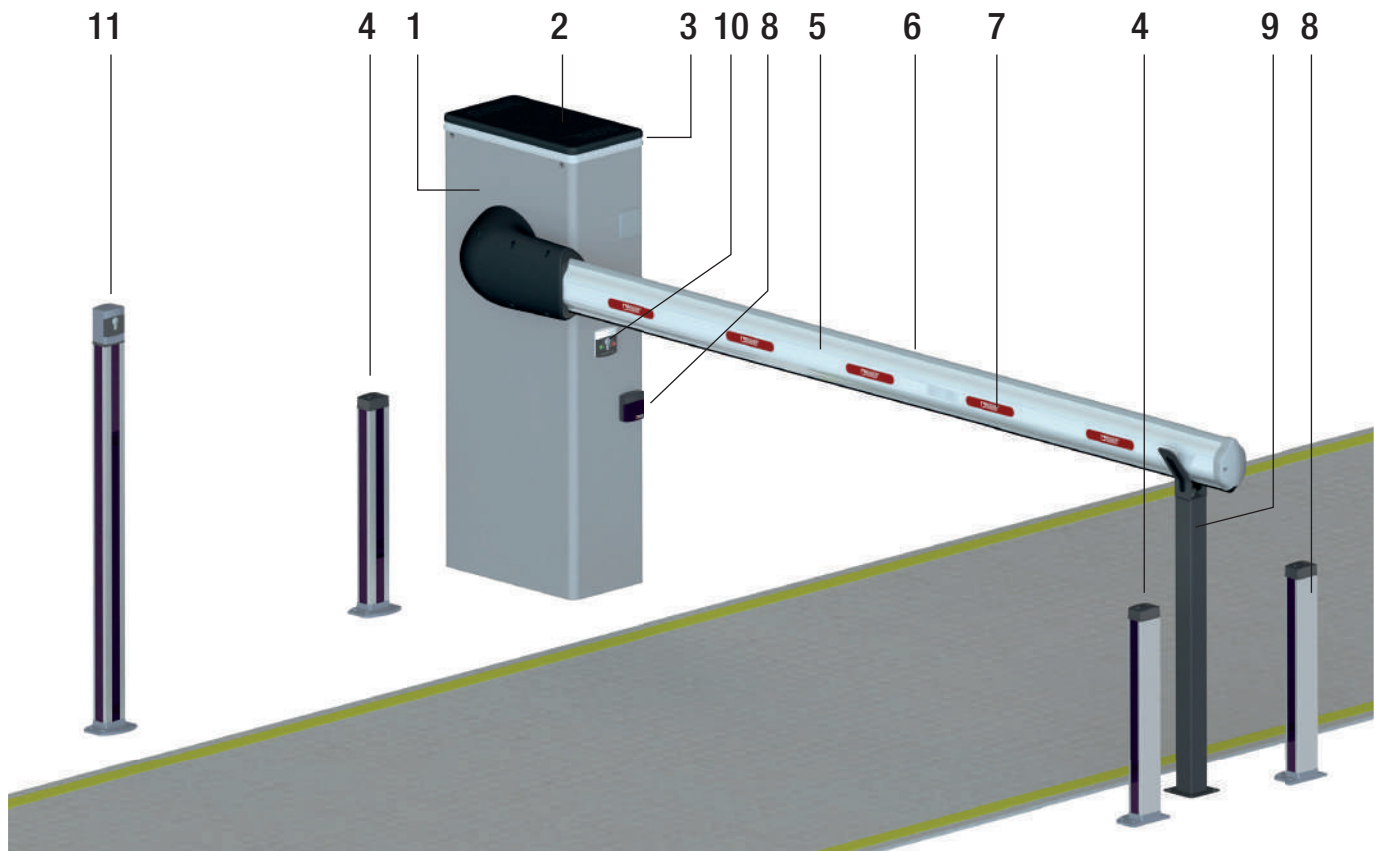

1	Automatic Barrier BIONIK
2	Integrated control unit
3	Flashing lights
4	External Photocell
5	Boom with shockproof rubber
6	Strip led

7	Reflective sticker
8	Internal Photocell
9	Boom's Fixed support for boom.
10	Release system
11	Key or keypad release switch

# 10 REFERENCES AND ACCESSORIES

EN

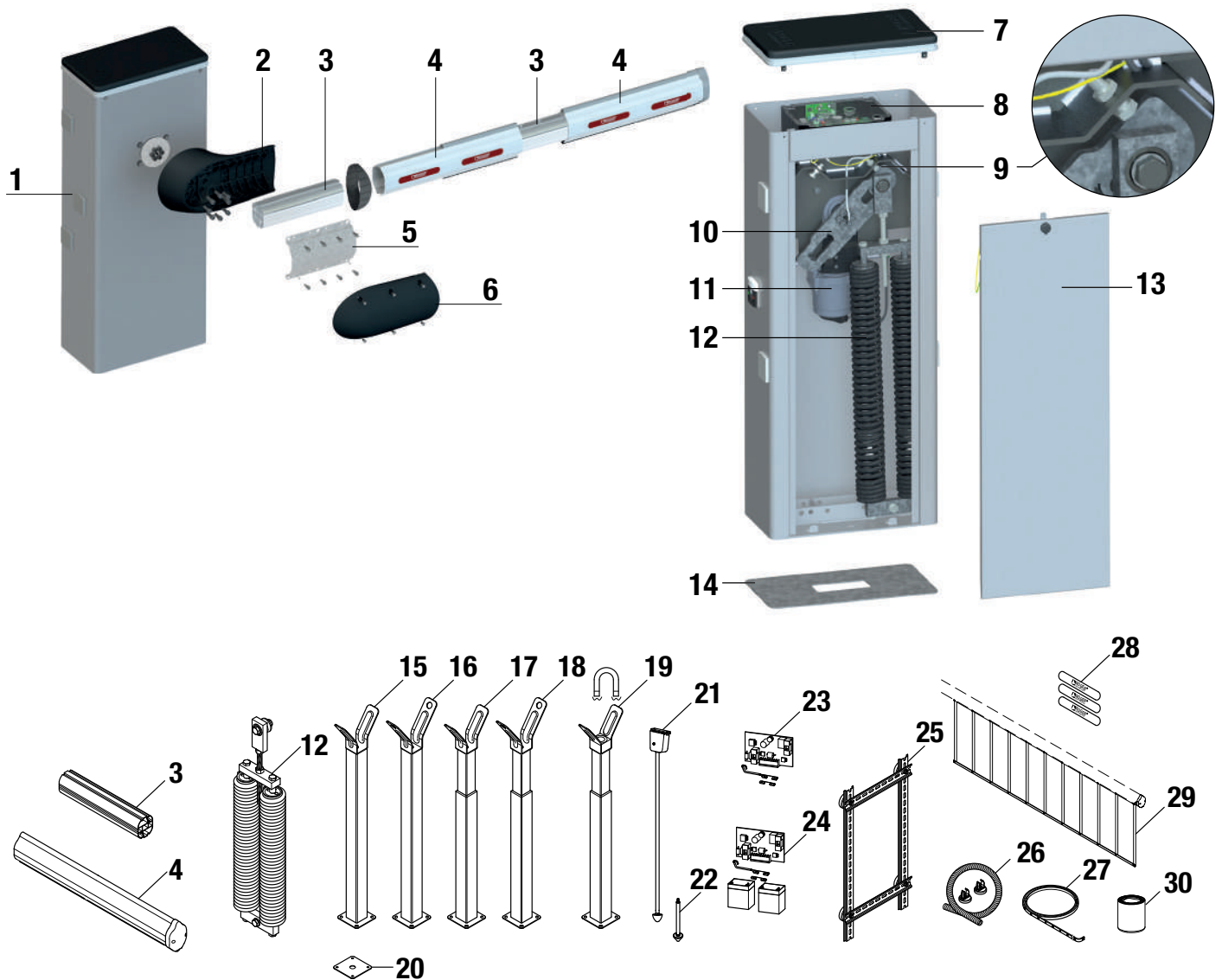

Code	Description
1	Carbon steel barrier assembly cabinet with anti-corrosion treatment, painted.
2	Aluminium boom support base, die-cast, with anti-corrosion treatment, painted.
3 JNT/BA/128	Internal connection joint made of anodized aluminium. n. 2 connection joints are mandatory.
4 BA/128/4	Boom L 4,1 m made of aluminium, with slot cover profiles and shockproof rubber.
5	Zinc coated steel boom fastening bracket
6	Aluminium boom fixing cover, die-cast, with anti-corrosion treatment, painted.
7	Head in die-cast aluminium with anti-corrosion treatment and painted, complete with diffuser in transparent polycarbonate and BI/BLED/8 led lights.
8 CTRL	Digital control unit
9	Mechanical stop in opening and closing.
10	Galvanized steel springs fixing arm.
11	Geared motor complete with brushless motor and absolute encoder.
12 SP/85/AS/02	2 Ø85 springs for booms up to 8 m.
13	Corrosion-resistant steel closing door, with anti-corrosion treatment, painted.
14 KT244	Galvanised foundation plate for securing the barrier.
15 BAFS/01	Fixed support with rubber, NOT-adjustable.

Code	Description
16 BAFS/03	Fixed support with rubber, NOT-adjustable, with provision of a bolt.
17 BAFS/02	Fixed support with rubber, adjustable, telescopic.
18 BAFS/04	Fixed support with rubber, adjustable, telescopic, with provision of a bolt.
19 BAFS/05	Fixed end rest with rubber, adjustable, telescopic with rubber buffer and integrated magnet.
20 KT231	Fixed support foundation plate.
21 BAMS/01	Mobile support for boom.
22 BAMS/01/EXT	Extension for mobile support
23 BI/BAT/KIT	Emergency battery kit complete with battery charger and wiring (optional).
24 BI/BCHP	Battery charge board complete with wiring (optional)
25 KT239	DIN Bar
26 KT242	Magnetic cable passage kit
27 ALED8C	Strip LED 8 metres with connections cable.
28 R99/BASB40	Pack of No. 40 reflective adhesive strips for the boom.
29 BARK/02	Painted aluminium rack in 2 metres modules.
30 RS/GR1/100	Lithium grease (EP LITIO).

# 11 INSTALLATION

## 11.1 Preliminary checks

- Check that the material received is in good condition and suitable for the application.
- Check that the operating limits of the product are not exceeded.
- Check that the site chosen for installation meets the overall space requirements of the product and that there are no obstacles hindering open or close manoeuvres.
- Check the concrete base for the barrier installation. The base must be cast in accordance with proper working practices, perfectly level and clean.

## 11.2 Installing base plate

- The illustrations herein are indicative only. The space necessary for fastening the automation system and the accessories may vary depending on the overall dimensions of the installation. The installer is responsible for determining the most suitable solution.
- Excavate a foundation pit measuring 1,5 m x 1 m x 0,5 m and fill with concrete reinforced with steel mesh.
- Fasten the 6 anchor ties to the plate (fig. 1). Note: the bottom nut must be tightened to the end of the thread on the screw so that the length Z is at least 40 mm.
- Sink the base plate with the anchors in the centre of the foundation pit, so that the surface is flush with the concrete and perfectly level. The corrugated cable conduits must protrude by a few centimetres from the centre of the plate (fig. 2).
- Installation on existing surfaces. Place the base plate on the surface and trace the positions of the fastener points. Drill the surface and insert 6 adequately sized expansion anchor bolts (purchased separately).

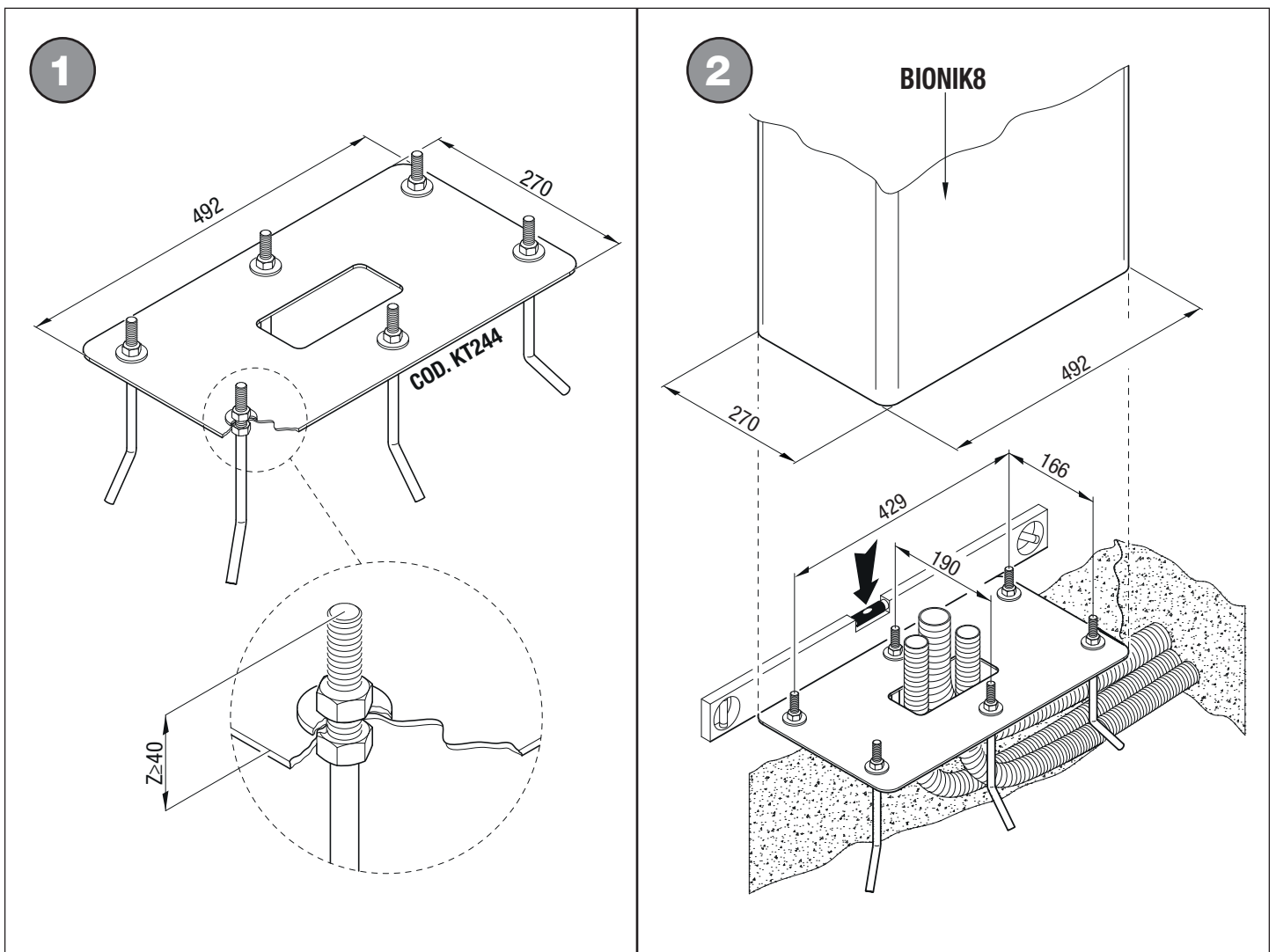

## 11.3 Installing the barrier

NOTE: the barrier is configured by default for installation on the right hand side (viewed from inspection hatch side).

- Undo and remove the washers and nuts from the anchors on the base plate (fig. 3).
- Open the inspection hatch, turning the key clockwise by 90° (fig. 4).
- Remove the inspection hatch (fig. 5).
- Place the cabinet on the plate. The anchors on the base plate must fit through the six slots.
- Fit the washers and nuts removed previously. Move the cabinet as necessary in the slots to adjust the position of the barrier correctly. Tighten the nuts securely (fig. 6).

3

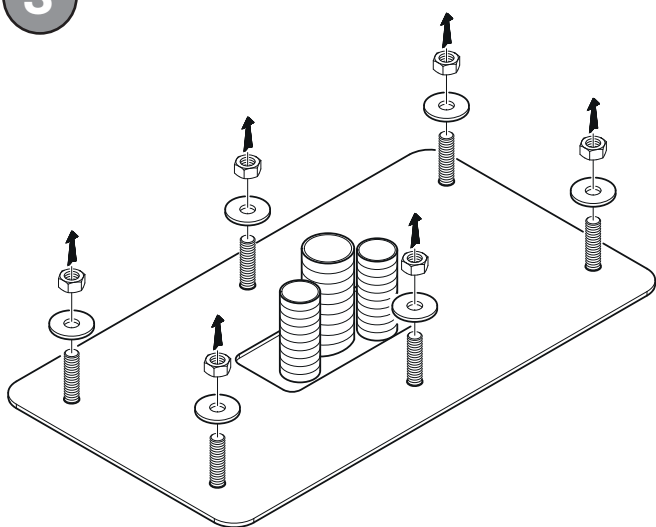

4

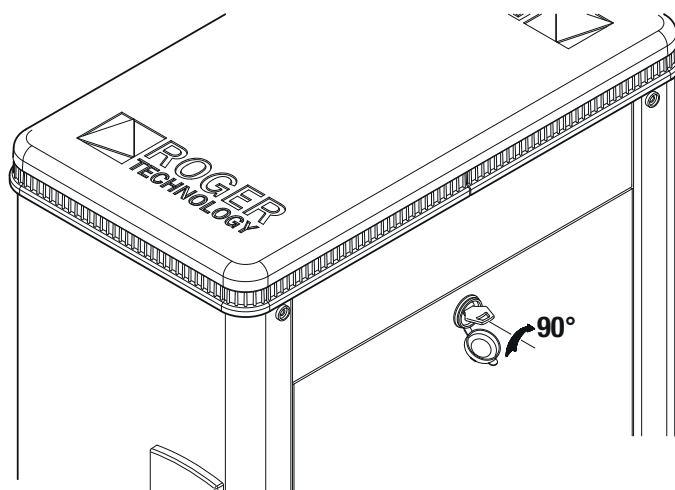

5

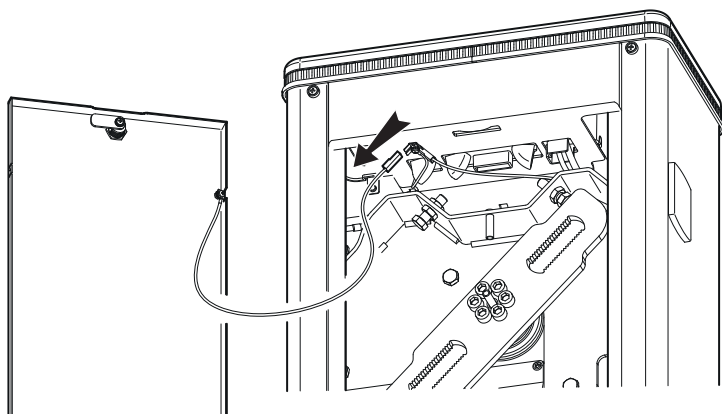

6

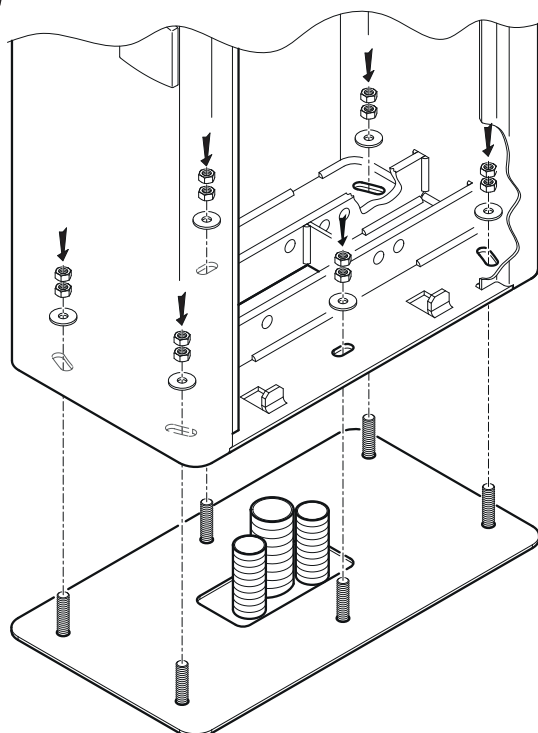

## 11.4 Selecting direction of aperture

**i** BIONIK barriers are configured by default for installation on the right hand side (seen from the inspection hatch side).

**!** Whenever corrective actions are carried out, pay the utmost attention when releasing, locking or moving the internal mechanical parts. These operations could be hazardous for the installer.

For LEFT hand installations:

1. Unlock the barrier (see chapter 23).
2. Turn the linkage lever as shown in fig. 8.
3. Move the mechanical stop (see chapter 14).
4. Lock the barrier (see chapter 23).

7

INSTALLATION OF  
THE LEFT

INSTALLATION ON  
THE RIGHT

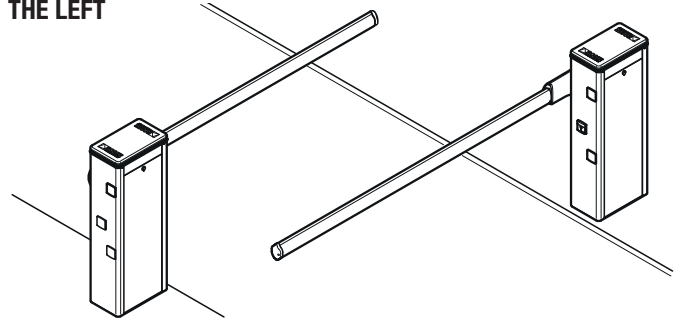

8

**BARRIER INSTALLED ON THE RIGHT (SEEN FROM THE INSPECTION HATCH SIDE) AND THE BOOM OPENING/CLOSURE GATE ON THE LEFT**

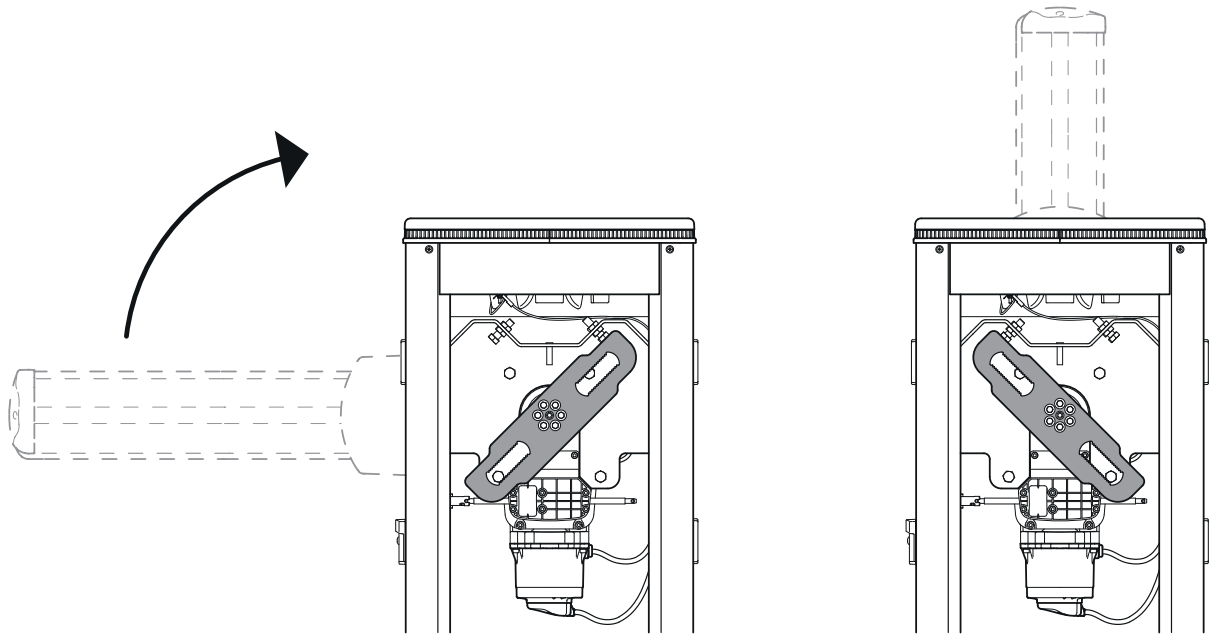

**BARRIER INSTALLED ON THE LEFT (SEEN FROM THE INSPECTION HATCH SIDE) AND THE BOOM OPENING/CLOSURE GATE ON THE RIGHT**

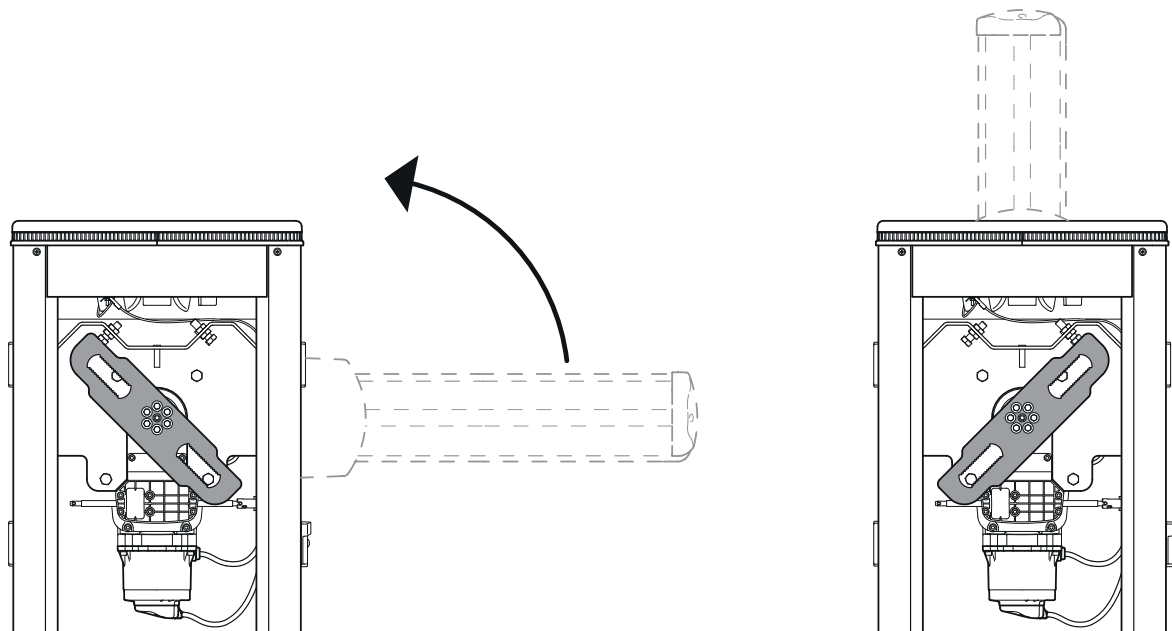



## 12 INSTALLING THE BOOM

**IMPORTANT:** The BIONIK8 barrier is supplied with two 4.1 m booms (**D1** and **D2**).

**WARNING!:** to avoid damaging the surface of the components, it is recommended to place them on a stable and soft surface.

- Unlock the barrier (see chapter 23).
- Turn the linkage lever into the position necessary for installing the boom horizontally.
- Lock the barrier.

### 12.1 D1 boom preparation (fig. 9)

- Remove the plug **Q1** and the end flange **R1**. These two parts will NOT be used again.
- Remove the led cover **N1** and shorten it by 285 mm from the side where it is fastened to the boom support.
- Remove the protective rubber **P1** and shorten it by 285 mm from the side where it is fastened to the boom support.
- Cut the excessive protective rubber at the opposite end as well.

### 12.2 D2 boom preparation (fig. 10)

- Remove the plug **Q2** and the end flange **R2**.
- Remove the led cover **N2** and the protective rubber **P2**. **CAUTION:** these two components should NOT be cut.

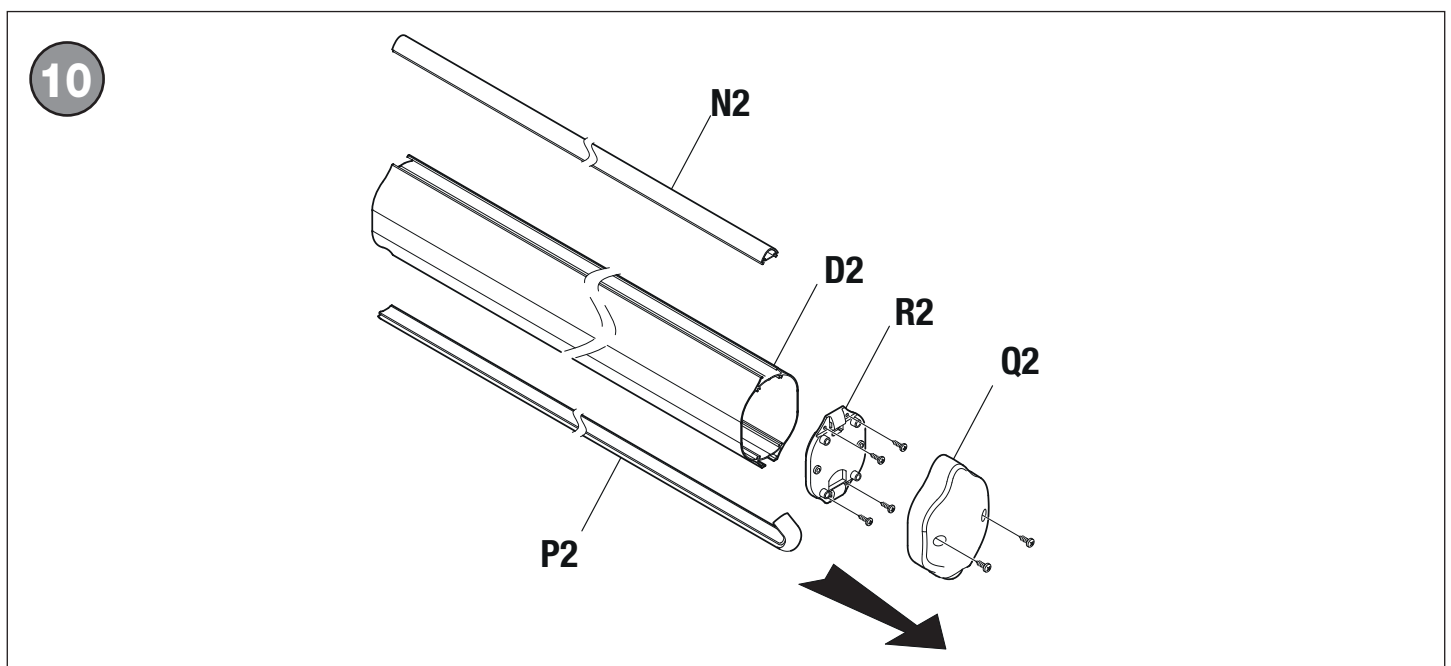
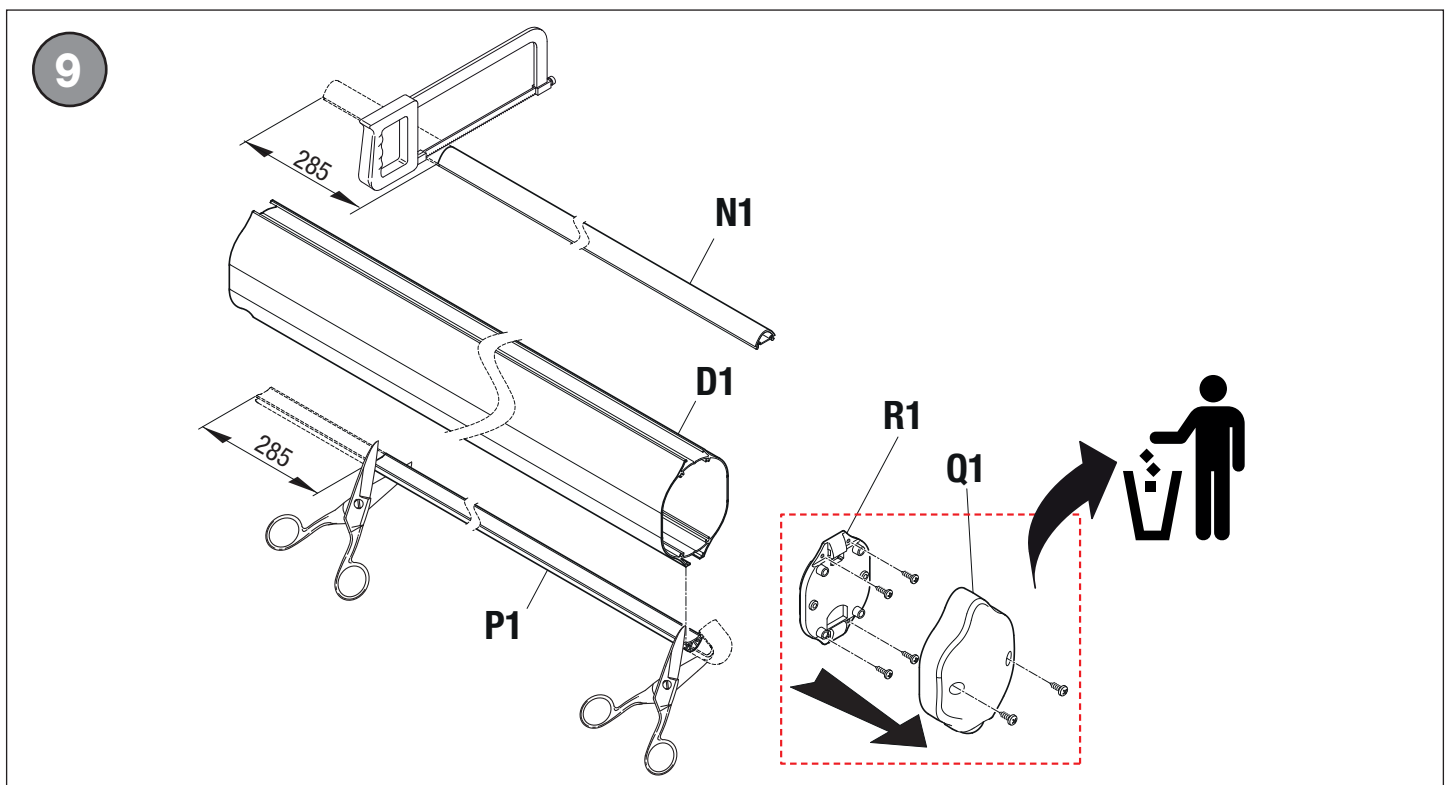

## 12.3 Installation procedure

1. Insert the connector **M1** on the boom **D1** by half of its length (375 mm), fig. 11.
2. Fasten the boom to the connector using the 10 self-drilling screws **L** included, 5 above and 5 under, along the boom axis, at a distance of 60 mm apart, fig. 11.
3. (Fig. 12) Insert the boom **D2** on the other half of the connector and fasten it according to the description above.
4. In this way, the boom will have a length of 8.2 m (fig. 12).
5. Fasten the boom support base **A** to the flange **C** with the 8 M12x30 zinc coated screws **B** and tighten them firmly (fig. 13).
6. Insert the connector **M2** completely inside the boom.
7. Fasten the boom to the connector **M2** with the 10 self-drilling screws **L** included, 5 above and 5 under, along the boom axis, at a distance of 60 mm apart, fig. 13.
8. Insert the finishing collar **I** on the boom.
9. Insert the boom in its seat on the support **A**.
10. Fit the steel bracket **F** and screw the 8 M10x20 zinc coated screws **E** on the boom support **A** and tighten them firmly.
11. Fasten the bracket **F** with 4 self-drilling screws **L** and tighten them firmly.
12. Insert the led covers on the boom, first the **N1** and then the **N2** and then the protective rubbers, first the **P1** and then the **P2** (fig. 14).
13. Lastly, fit the aluminium cover **G** and fasten it with the 6 M8 stainless steel screws **H**, included.
14. Refit the end flange **R2** and the plug **Q2** fastening them with the two screws included.

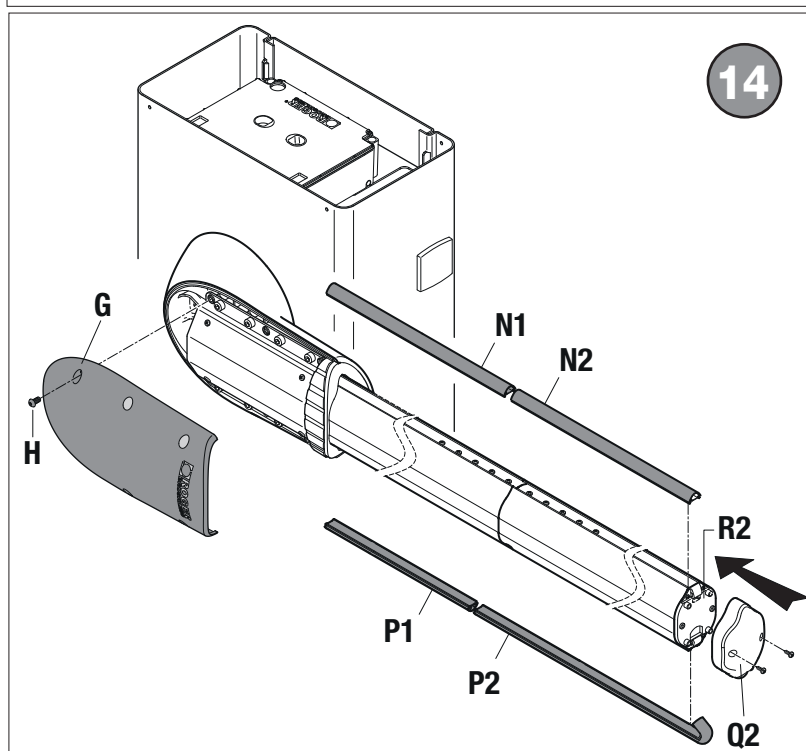
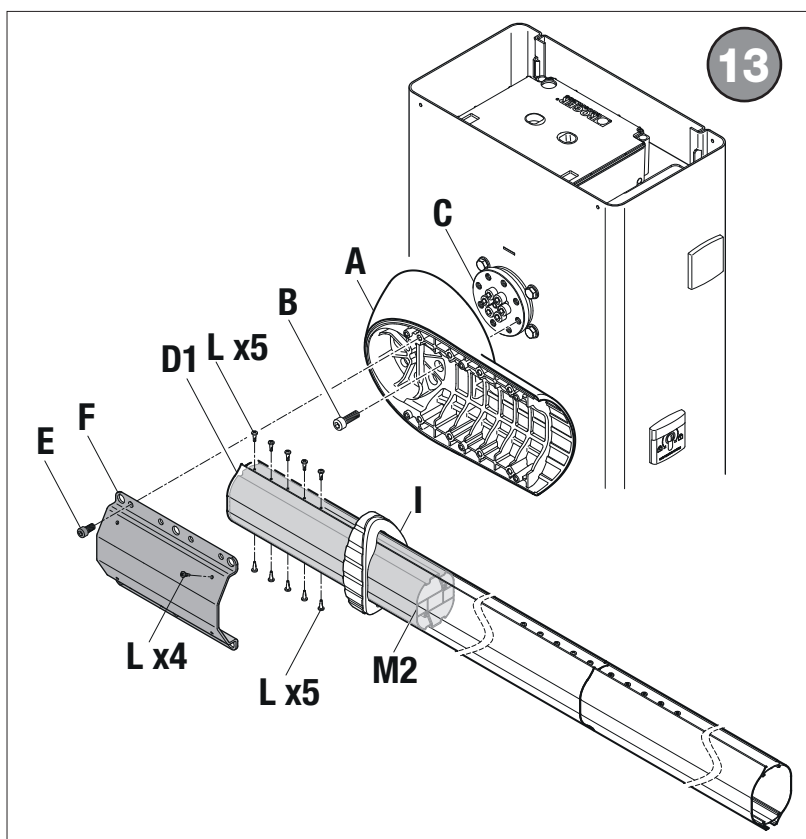
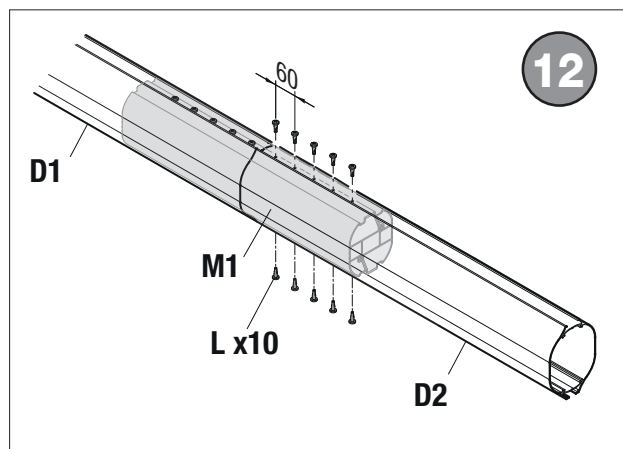
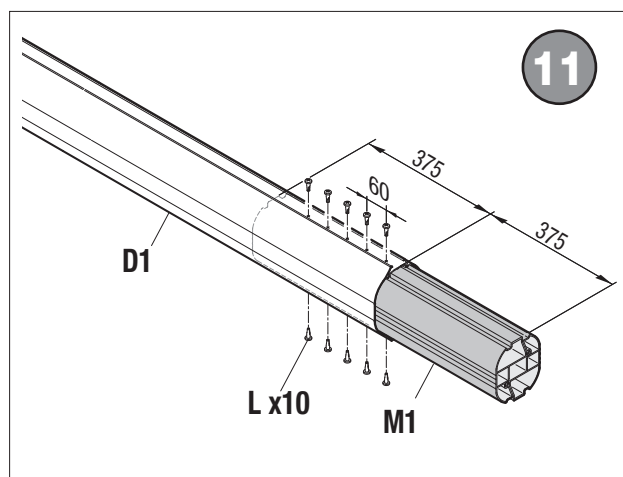

# 13 INSTALLING AND ADJUSTING THE SPRING

**i** For choosing the most suitable configuration, the booms are understood as complete with shock-resistant rubber and LED strips.

EN

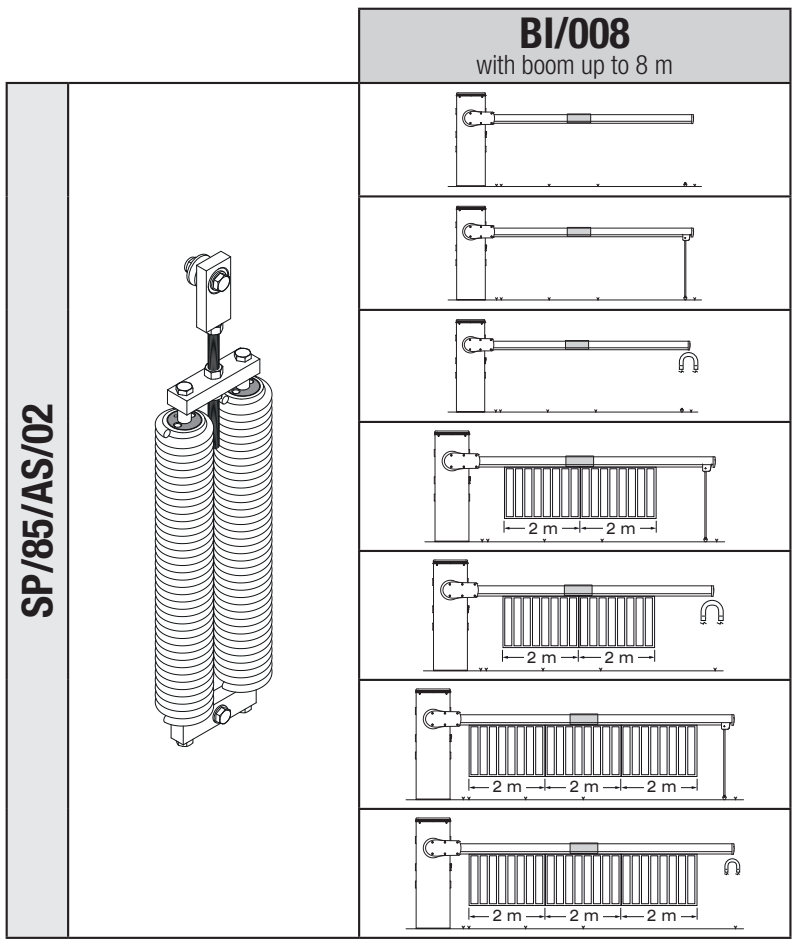

\* The adjustable fixed end rest with integrated magnet BAFS/05 must be used.

\* The adjustable fixed end rest with integrated magnet BAFS/05 must be used.

\* The adjustable fixed end rest with integrated magnet BAFS/05 must be used.

**! WARNING!** For booms of 4 m or more, it is mandatory to use the BAFS fixed end rest or the BAMS hinged end rest.

## 13.1 Installation and adjustment of the balancing unit

- The balancing unit is composed of a linkage lever, a slider [CU] and a spring unit.
- The linkage lever has two 4 mm pitch toothed windows, on which the [CU] slide will be fit.
- On one of the holes on the slider [CU] the SPRING SET SP/85/AS/02 will be fit.
- The supplied sliders are of two types **CU1** and **CU2** and can be distinguished by the identifying marks (see \* and \*\*). The two types of sliders allow millimetre adjustment of the spring travel, since the spacing between the holes is different (26-24 mm), see details in fig. 15 and 16.
- Fit the most appropriate slider **CU** for a correct balancing of the boom.

## 13.2 Slider selection

- ⚠ The correct position of the slider is determined by the boom weight: the heavier the boom is (weight determined by the totality of the accessories installed), the more to the outside the slider should be installed.
- Reversing the insertion direction of the slider, rotating it by 180°, the hole spacing value is modified in relation to the linkage lever centre, see fig. 15 and 16 (e.g. 135, 136, 137, 138 mm values).
- To decrease the travel (extension) of the spring, move the slider **CU** inward by one pitch in the linkage lever and check the tensioning of the springs.
- Each pitch reduces the travel value by 4 mm..

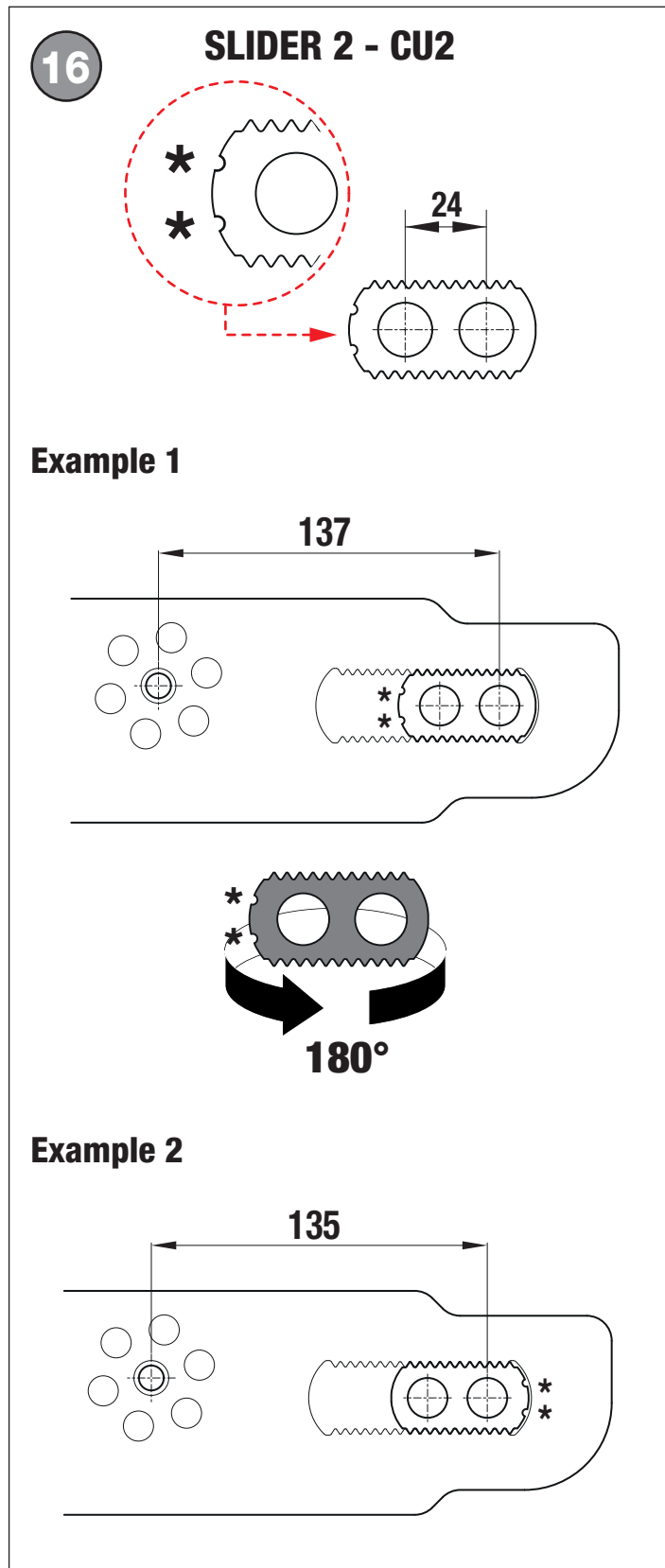
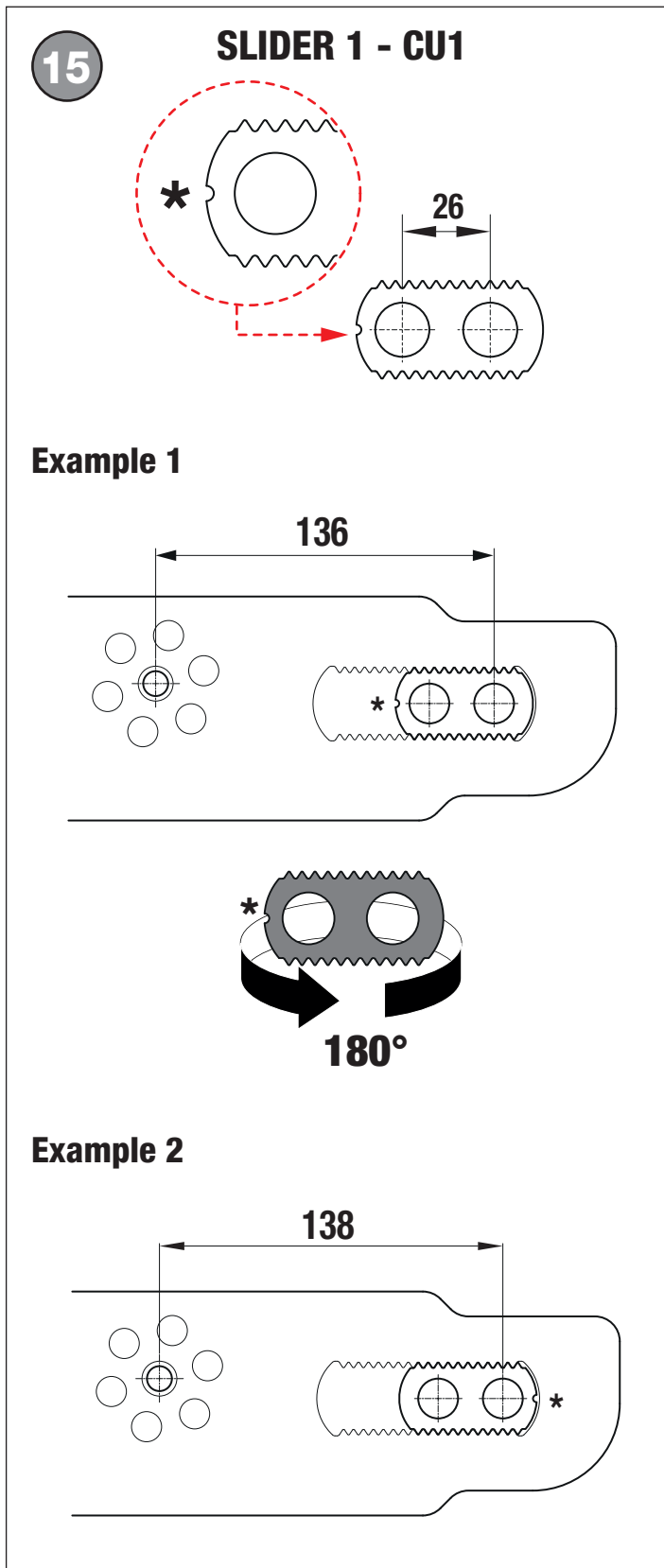

## 13.3 Spring unit installation

1. Unlock the barrier (see chapter 23) and move the boom into the completely open vertical position.
  2. Fasten the spring unit **SP/85/AS/02** to the linkage lever using the screws included (fig. 17), according to the opening direction and in the position that allows the correct movement of the barrier. The internal roller bearing **[S]** is composed of 3 modular elements which, if incorrectly assembled, inhibit the correct operation of the barrier.
- CAUTION:** using the slider hole that is the farthest from the linkage lever centre, during barrier operation, the springs will be more tensioned, while, vice versa, when using the slider hole that is the closest to the linkage lever centre, the springs will be less tensioned.
3. Fasten the springs to the fixed structure (fig. 18) on the steel cross bar of the barrier, using the screws included. The heavier the boom is (totality of the accessories installed), the more to the outside the springs should be installed (hole **A**).
  4. Check the correct operation of the balancing system.
    - Lift the boom manually to an angle of 45° and let go. If the boom rises or falls, try another position of the slider **CU1**. Whenever this is not sufficient, the slider can be rotated by 180°, to change the 2 mm holes pitch (fig. 15 - values 136 and 138).
    - To obtain millimetre precision, replace CU1 with the **CU2** slider included (fig. 16 - values 135 and 137).
  5. Grease the points indicated in fig. 17 and 18 with LITHIUM grease (EP LITHIUM). Available upon request, article **RS/GR1/100**: 100 g can of lithium grease.

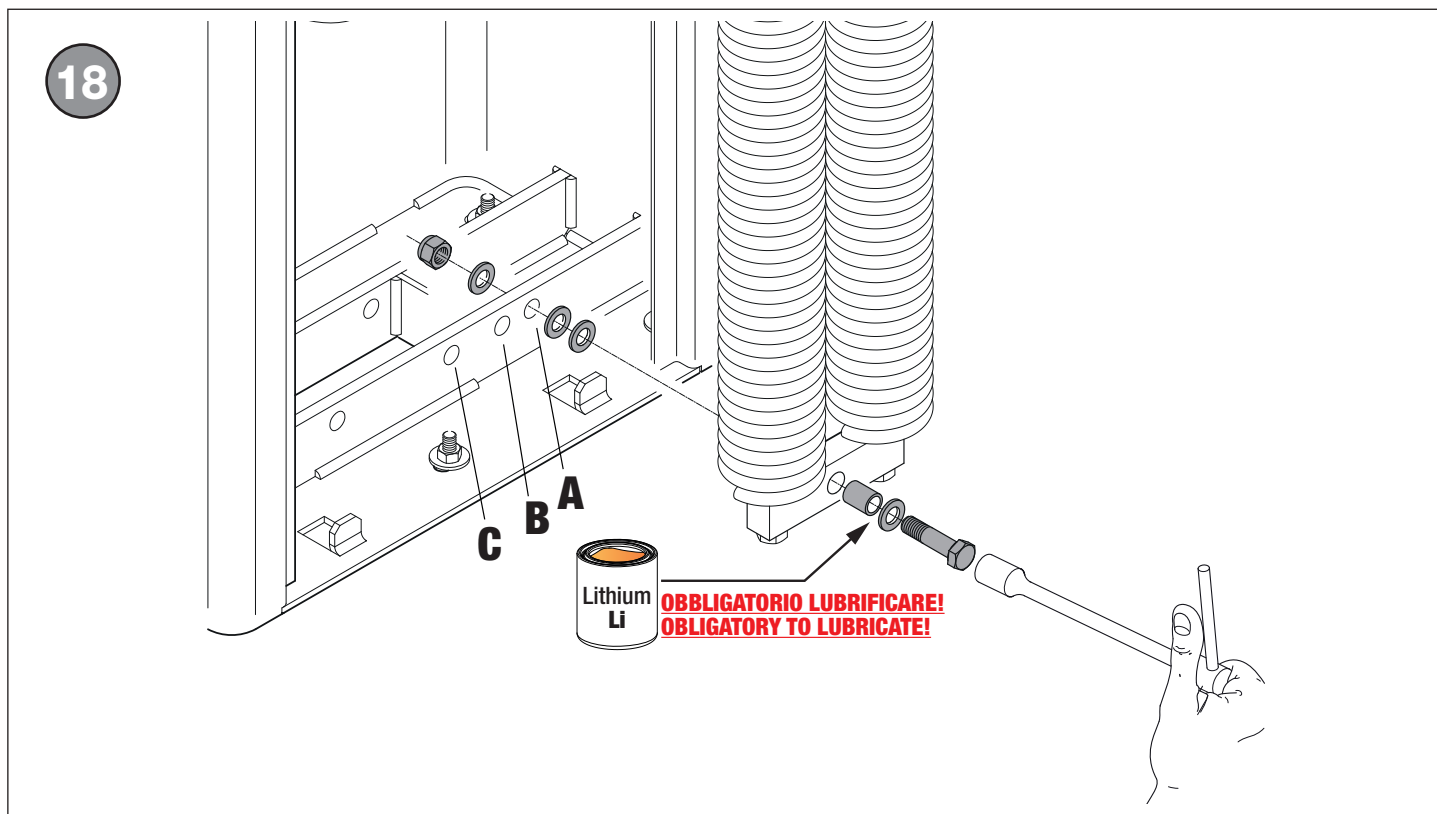
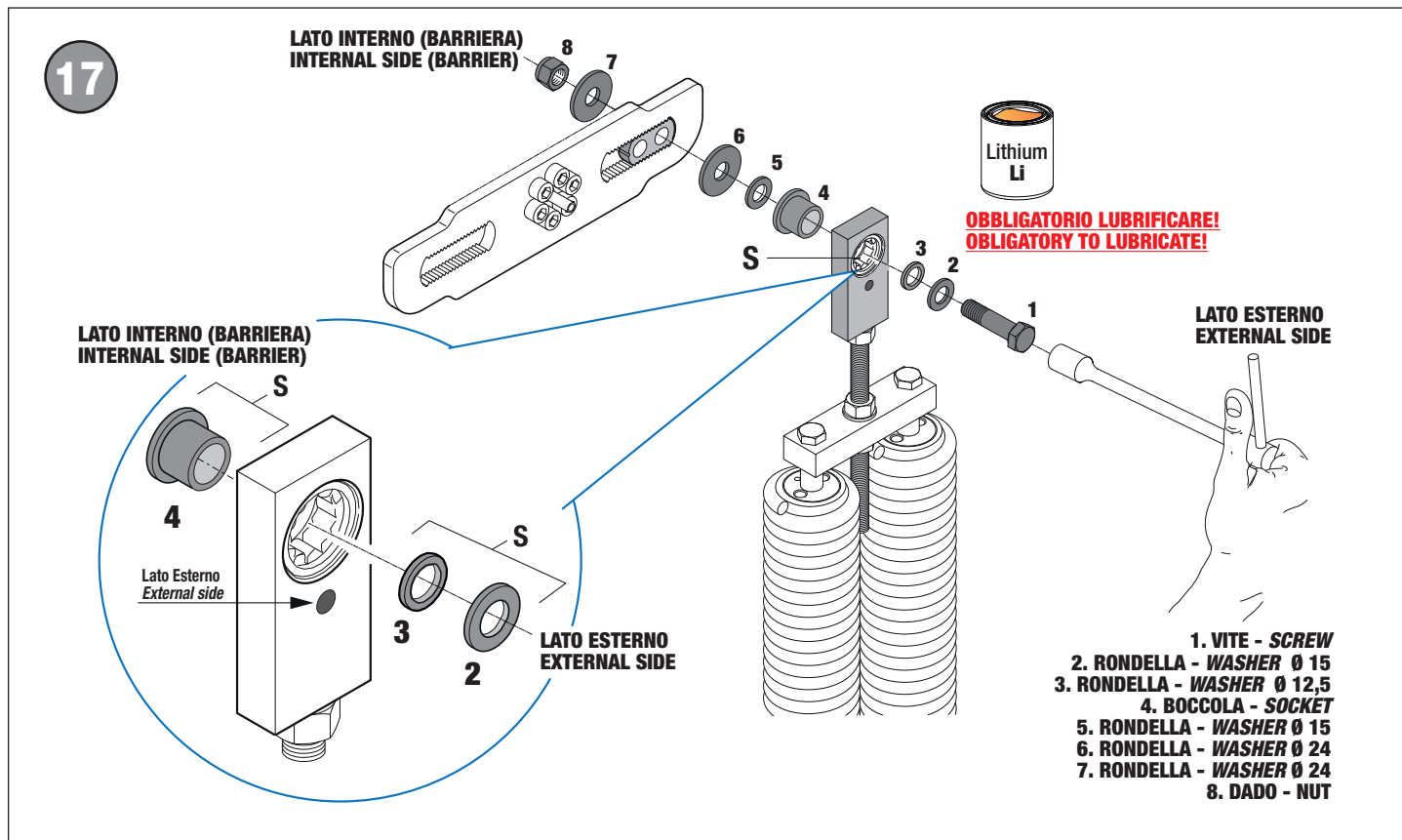

## 13.4 Spring adjustment

1. Adjust the spring tensioning by loosening the nuts **[A]** as indicated in fig. 19.
2. By moving upward the fastening cross bar **[B]**, the spring tensioning increases; vice versa, by moving it downward, the tensioning decreases.
3. Lift the boom manually to an angle of  $45^\circ$  and let go. If the boom rises, reduce the spring tension. If the boom falls, increase the spring tension (fig. 20).
4. Once the spring tension is correct, tighten the lock nuts securely.

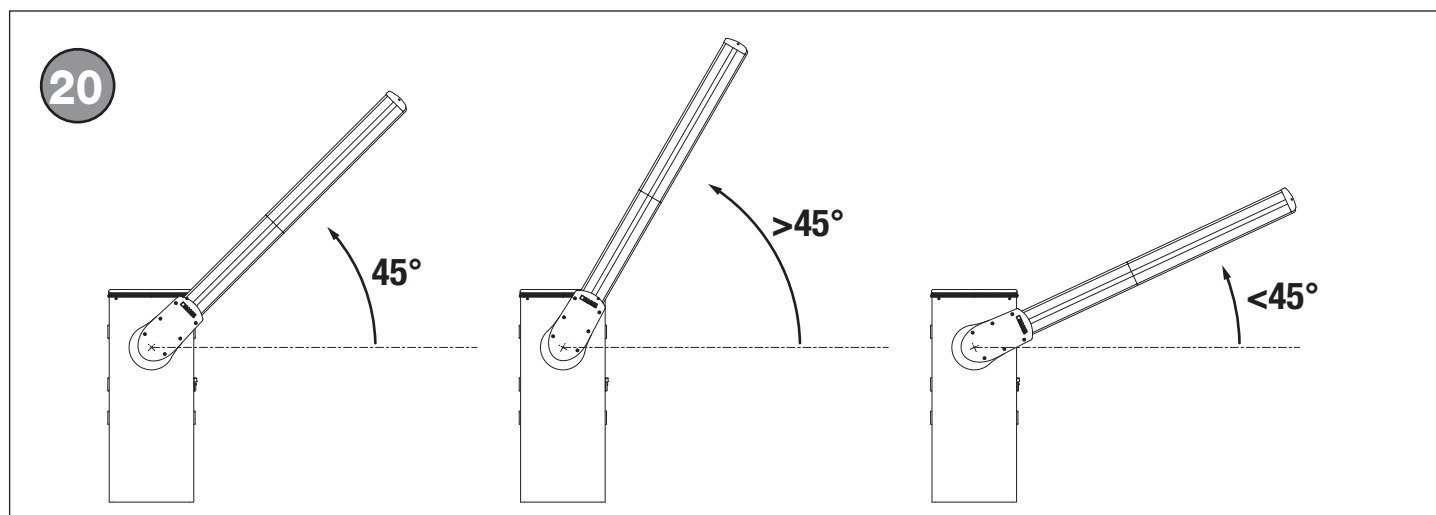
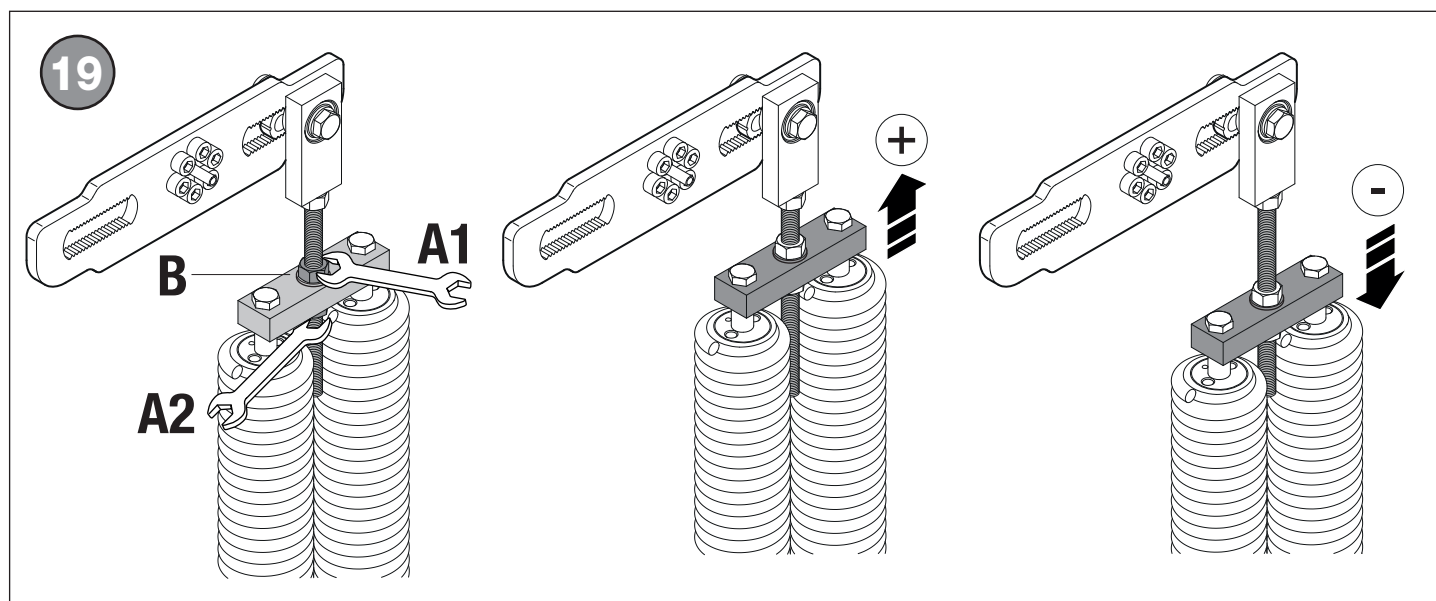

## 14 ADJUSTING MECHANICAL STOP

THE

21

Figure 21 shows the mechanical stop on a barrier installed on the RIGHT hand side. For barriers installed on the LEFT, perform the mirror images of the procedures illustrated.

- Unlock the barrier (see chapter 23).
- Set the completely open **AP** and completely closed **CH** positions by adjusting the relative mechanical stops.
- Lock the barrier (see chapter 23).

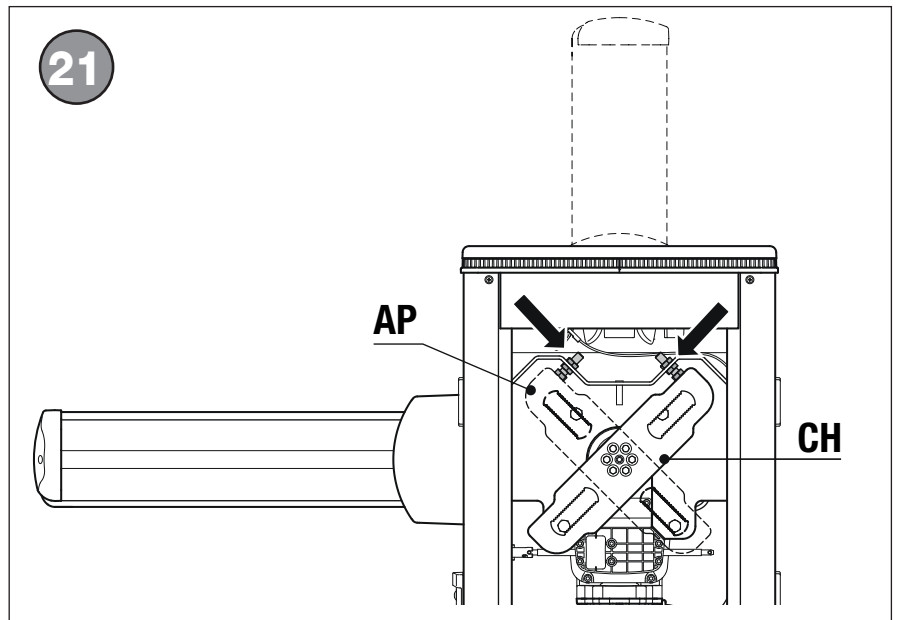

## 15 INSTALLING THE LOCK RELEASE SYSTEM

The lock release system is already installed in the factory on one of the two side of the barrier.

If it is necessary to install the system on the opposite side:

- Open the inspection hatch.
- Remove the screws fastening the plastic cover [A].
- Remove the escutcheon plate [B] of the lock release system, prising the lateral clips open to detach.
- Undo the two self-tapping screws [C] and remove the aluminium front panel [D].
- Undo the four M5 nuts [E].
- Push the steel connector [F] outwards to compress the spring and rotate by 45°.
- Detach the lock release system and install on the opposite side, taking care not to damage the safety cable.

**NOTE:** two coloured caps (red and green) are fitted to check that the lock release system is installed correctly, regardless of which side it is fitted on.

When the barrier is locked, the green cap must face towards the inspection hatch (installer view). If not, the lock release system is installed incorrectly.

- Tighten the nuts [E].
- Fit the aluminium front panel [D] and fasten with the screws [C].
- Fasten the escutcheon plate [B] on the lock release system.
- Fit the plastic cover [A] on the opposite side.

22

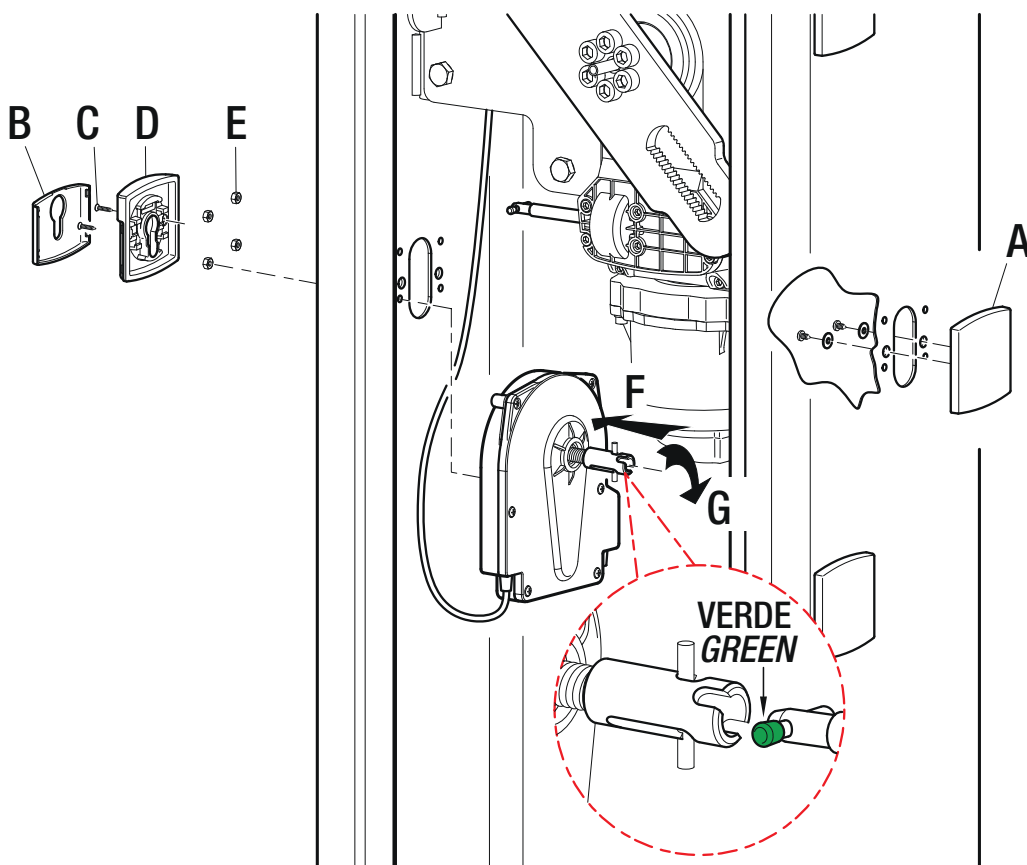

## 16 CONNECTING PHOTOCELLS

**G90/F4ES** photocells may be installed on both sides of the barrier at two different heights: (50 cm or 100 cm).

- Disconnect from mains electricity and from battery power (if applicable).
- Open the inspection hatch, turning the key clockwise by 90°.
- Undo the four screws fastening the head.
- Remove the head after disconnecting the flashing light cables.
- Open the cover of the **CTRL** control unit.
- Undo the two screws fastening the plastic cover of the photocell housing from the inside.
- Fasten the **G90/F4ES** photocells to the barrier.
- Route the connector cables upwards, taking care not to interfere with the movements of the automation system, and push them through one of the openings on the control unit box.
- Connect the photocell cables to the specific terminals as indicated in the installation manual for the **CTRL** controller.
- See the **CTRL** control unit manual for instructions on setting the photocells.
- Close the control unit cover correctly, ensuring that it is watertight.
- Refit the barrier head.
- Close the inspection hatch, turning the key anticlockwise by 90°.
- Tighten the four screws to the head.

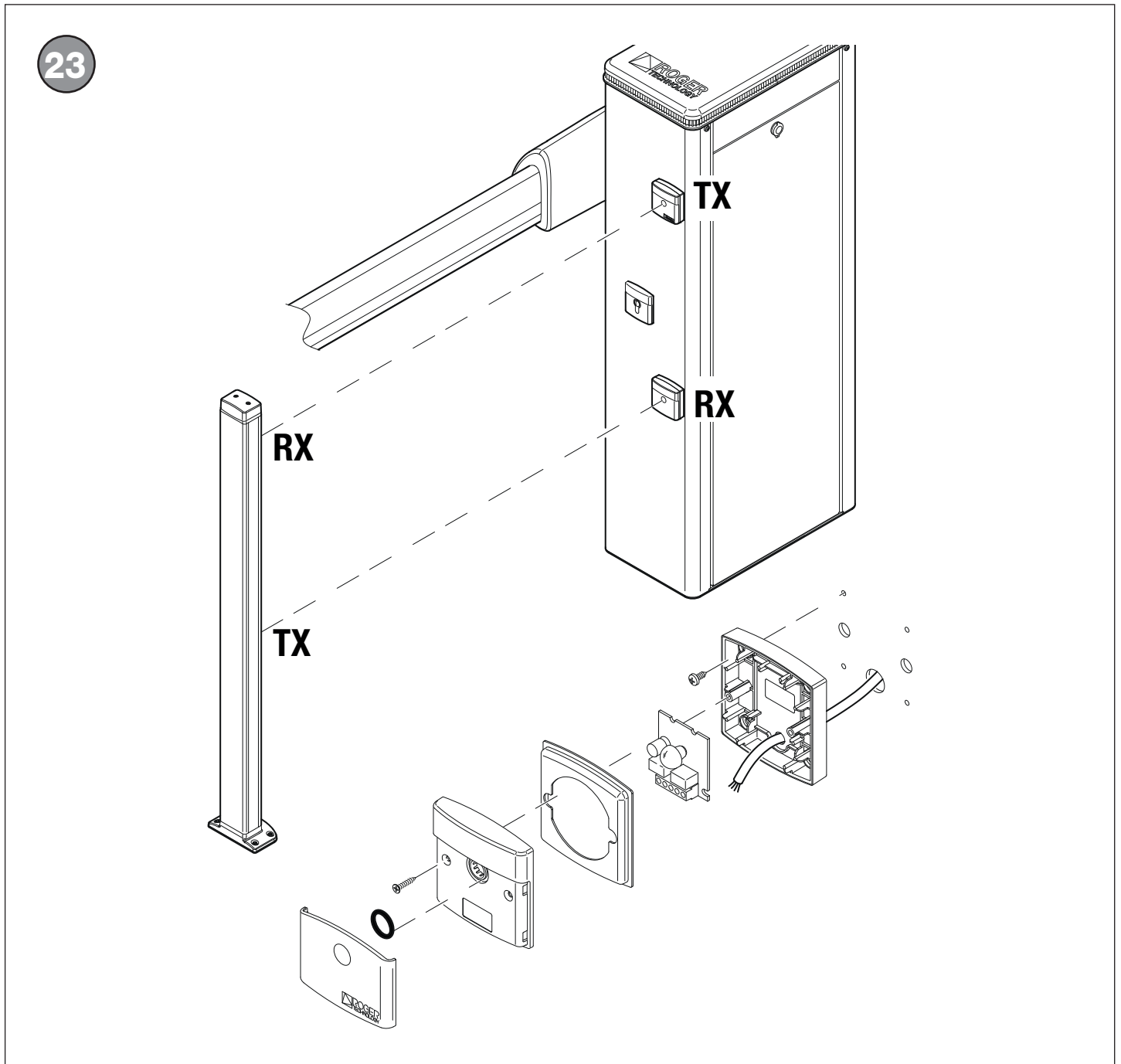



## 17 ELECTRICAL CONNECTIONS

All electrical connections must be made with the unit disconnected from mains power and, if applicable, battery power.

See the **CTRL** controller manual for instructions on making connections and programming.

Before connecting to electrical power, ensure that the mains power specifications on the identification plate match the mains power supply used.

A switch or an omnipolar cut-off switch with a contact opening of at least 3 mm must be installed on the mains power line.

Ensure that an adequate residual current circuit breaker and a suitable overcurrent cut-out are installed ahead of the electrical installation.

Use a 3x2.5 mm<sup>2</sup> double insulated cable for the mains power line.

Feed the cable on the left hand side of the barrier through the openings on the left hand side of the controller casing and connect it to the terminals L (brown), N (blue) and  $\ominus$  (yellow/green) inside the automation unit.

Fasten the power cable with the cable grips included.

At least 50 mm of the connector cable conduit must protrude from the holes in the base plate and into the automation unit.

Ensure that there are no sharp edges which could damage the power cable.

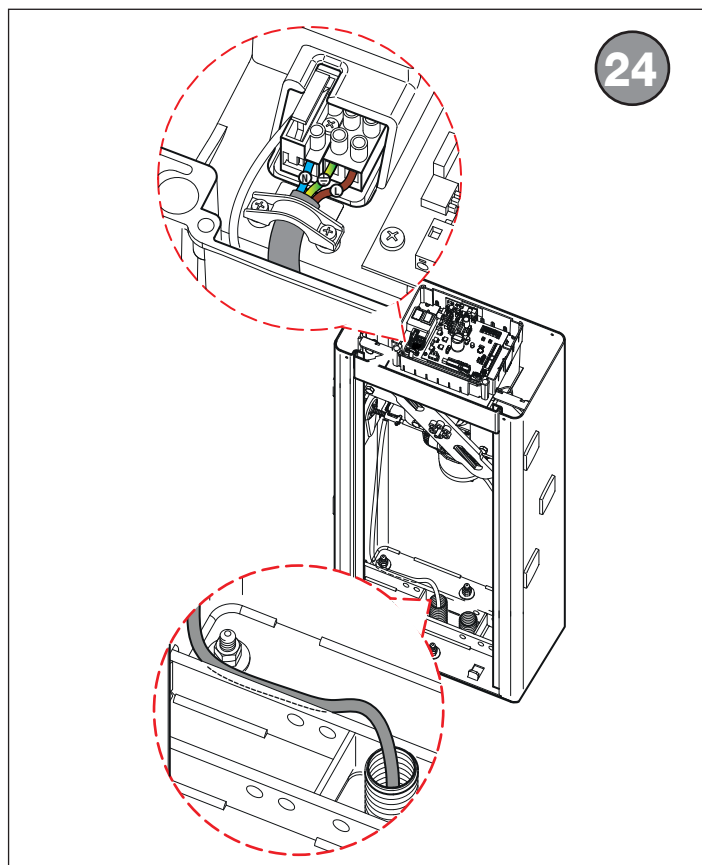

## 18 INSTALLING THE BATTERY KIT (OPTIONAL)

1. Disconnect the mains power.
2. Unscrew the four screws [Z] and remove the head [A] (if applicable).
3. Lift the cable grommet [B] and disconnect the connector [C].
4. Open the transparent control unit cover [D].
5. Switch the control unit switch to the OFF position [E].
6. Lift the control unit and insert the batteries in their housing [F].
7. Connect the red, black and blue wires to the batteries (see detailed view)
8. Connect the batteries to the **+BATTERY** terminal (red wire) and **-BATTERY** terminal (black wire).
9. Insert the battery charge board **BI/BCHP** in the plug-in connector [G].
10. Reposition the control unit.
11. Switch the control unit switch to the ON position [E].
12. Reposition the transparent control unit cover [D].
13. Reconnect the connector [C] and close the cable grommet [B].
14. Close the head [A] and tighten the four front screws [Z].
15. Reconnect the mains power.

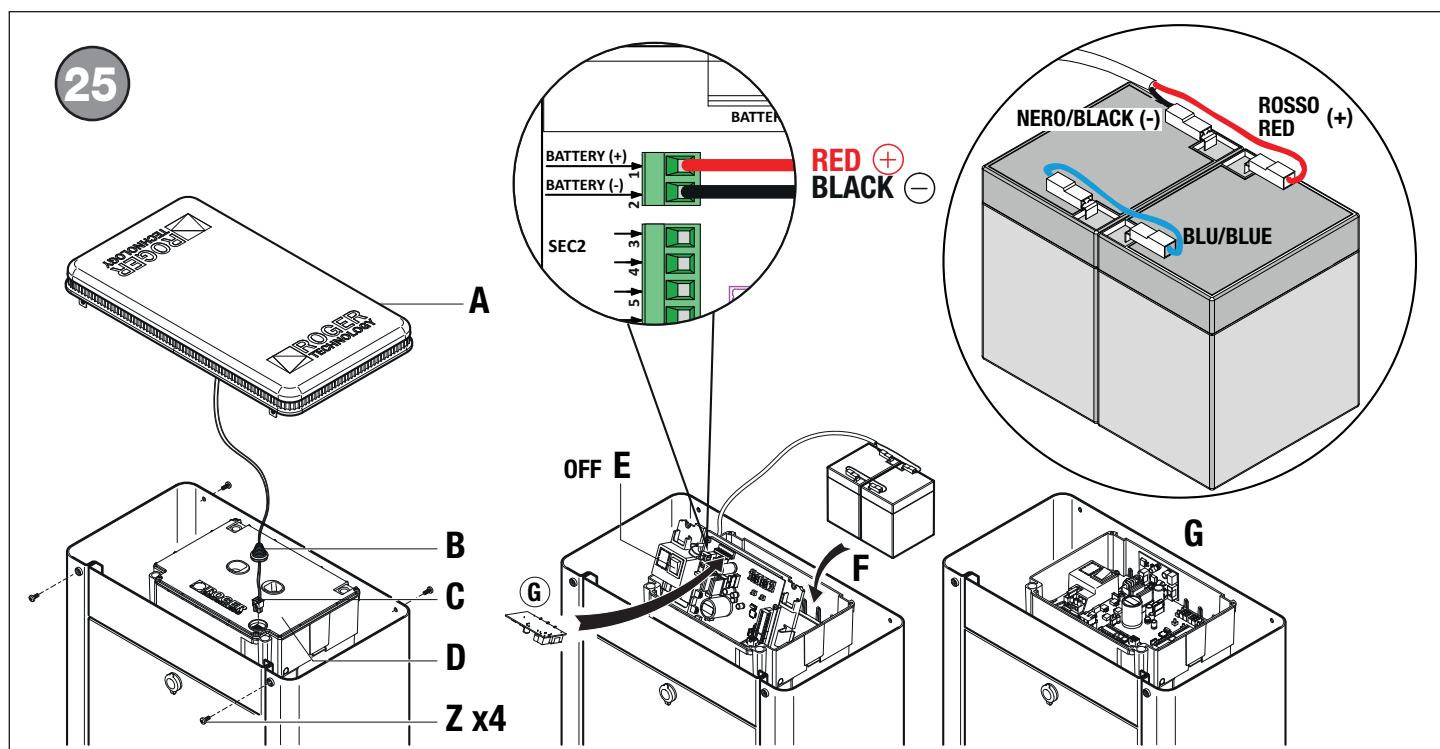

## 19 INSTALLING THE BI/BLED/8 LED FLASHING LIGHT (fig. 26-27)

The BI/BLED/8 flashing lamp unit is factory supplied already pre-installed in the head [A], packaged separately inside the BIONIK package.

1. Insert the connector [B] in the LIGHT terminal of the control unit.
2. Refer to the control unit manual for the flashing lamp unit settings.
3. Fasten the cable grommet [C], making sure it is positioned correctly.
4. Position the head [A] on the barrier.
5. Tighten the four fastening screws [Z].

### In case of replacement:

1. Disconnect the mains and battery power supplies (if applicable).
2. Unscrew the four screws [Z] that fasten the head [A] to the barrier.
3. Lift the cable grommet [C].
4. Disconnect the connector [B].
5. Remove and overturn the head [A].
6. Remove the BI/BLED/8 flashing lamp unit [D] from the diffuser.
7. Insert the new LED circuit in the diffuser, paying attention to the installation direction (fig. 27).
8. Insert the connector [B] in the LIGHT terminal of the control unit CTRL.
9. Refer to the control unit manual for the flashing lamp unit settings.
10. Fasten the cable grommet [C], making sure it is positioned correctly.
11. Reposition the head [A] on the barrier.
12. Tighten the four fastening screws [Z].
13. Reconnect the mains and battery power supplies (if applicable).

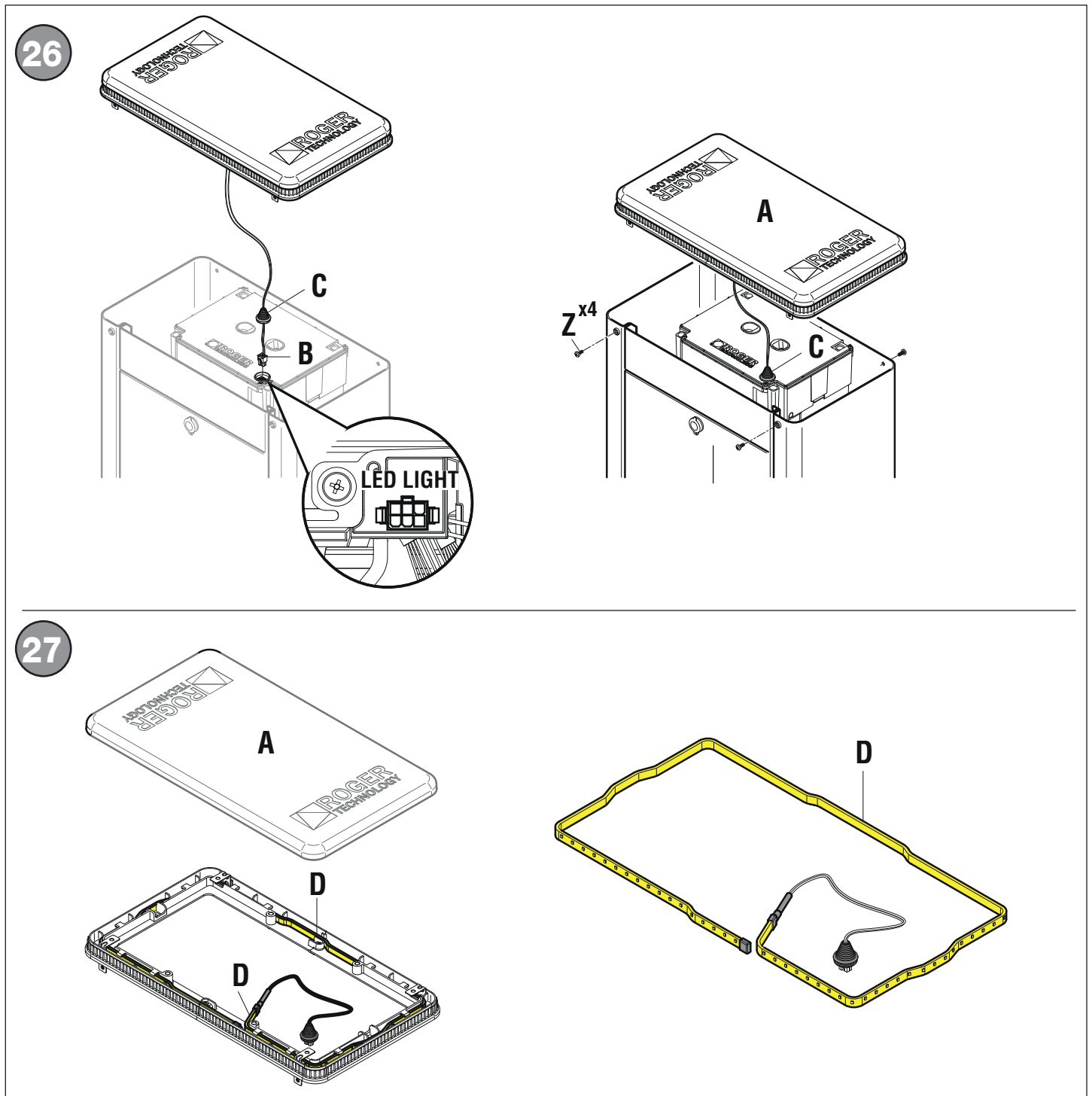

## 20 MAINTENANCE

**N.B.:** Only use original spare parts when repairing or replacing products. The installer must provide the user with complete instruction for using the motorised door or gate in automatic, manual and emergency modes, and must hand the operating instructions to the user of the installation upon completion. The installer must compile the maintenance log book, in which all scheduled and unscheduled maintenance operations performed must be indicated.

- The installation must be subject to regular maintenance. We recommend servicing at least once every 6 months.
  - Disconnect from mains electricity and from battery power (if applicable) to avoid the risk of accident or injury.
  - Check the tightness of all the fastener screws and nuts.
  - Clean the photocell lenses with a cloth moistened slightly with water. Do not use solvents or other chemical products, as these may damage the electronic components.
  - Clean and lubricate the pivot points with lithium based grease (EP LITIO).
  - Check the electrical connections.
  - Check that the manual lock release system works.
  - Check that the boom is balanced correctly as indicated in chapter 13.
  - Check that there are no plants within the radius of action of the boom which could interfere with the photocells or with the movements of the boom itself.
- Reconnect to mains power.
- Check that the safety devices and all the control functions work correctly.
  - Check that the obstacle detection function works correctly.
  - Check that there is no risk of the boom accidentally lifting persons or objects.
  - Check that the force limiting function prevent potentially dangerous situations in compliance with the standard EN 12445.

## 21 DISPOSAL



This product may only be uninstalled by qualified technical personnel, following suitable procedures for removing the product correctly and safely.

This product consists of numerous different materials.

Some of these materials may be recycled, while others must be disposed of correctly at the specific recycling or waste management facilities indicated by local legislation applicable for this category of product.

Do not dispose of this product as domestic refuse.

Observe local legislation for differentiated refuse collection, or hand the product over to the vendor when purchasing an equivalent new product.

Local legislation may envisage severe fines for the incorrect disposal of this product. Warning! some parts of this product may contain substances that are harmful to the environment or dangerous and which may cause damage to the environment or health risks if disposed of incorrectly.

## 22 ADDITIONAL INFORMATION AND CONTACT

ROGER TECHNOLOGY is the exclusive proprietor holder of all rights regarding this publication.

ROGER TECHNOLOGY reserves the right to implement any modifications without prior notification. Copying, scanning or any alterations to this document are prohibited without express prior authorised from by ROGER TECHNOLOGY.

### ROGER TECHNOLOGY CUSTOMER SERVICE:

business hours: Monday to Friday  
08:00 to 12:00 - 13:30 to 17:30

Telephone no: +39 041 5937023

E-mail: [service@rogertechnology.it](mailto:service@rogertechnology.it)

Skype: service\_rogertechnology

## 23 RELEASE AND LOCK PROCEDURE

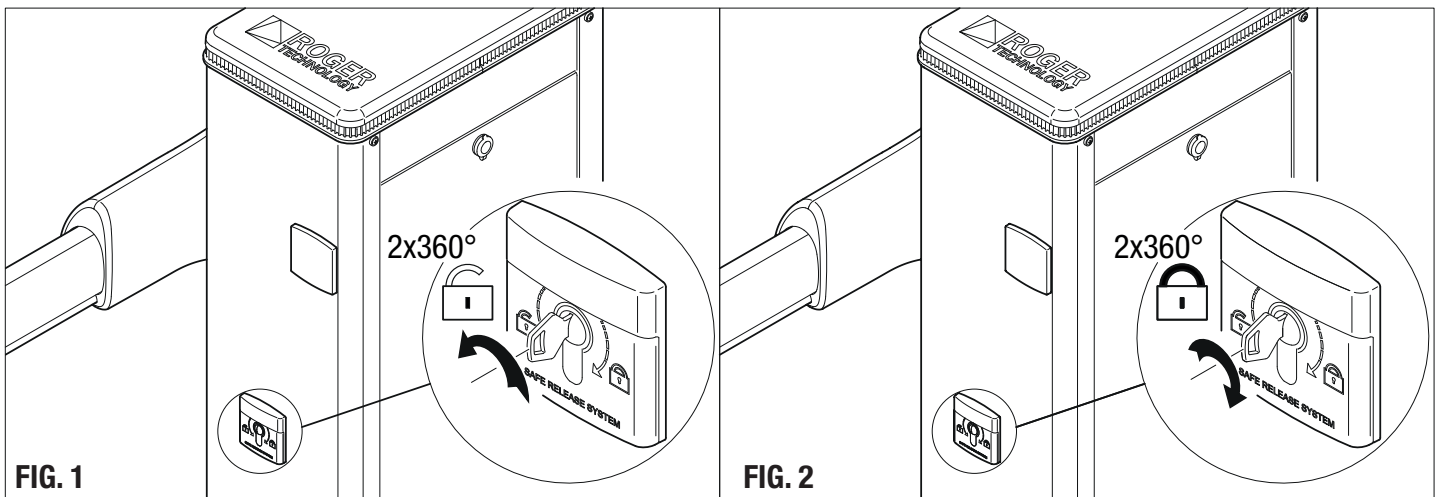

**!** Whenever corrective actions are carried out, pay the utmost attention when releasing, locking or moving the internal mechanical parts. These operations could be hazardous for the installer.

In some situations, such as in the event of a power outage or scheduled or extraordinary maintenance, it is necessary to release the automation.

The operation of the release of the automation must be carried out when the boom is stopped in the closed position (horizontal).

Moreover, ensure that at the time of release, no person, animal, item or vehicle is passing by or stopped within range of automation.

### RELEASE AND MANUAL OPERATION

Insert the key included into the lock and turn it anticlockwise by 360° making 2 complete turns, as indicated in fig. 1.

Move the boom manually.

### RESTORING AUTOMATIC OPERATION

To lock the barrier again, turn the key clockwise by 360° making 2 complete turns, as indicated in fig. 2.

Remove the key and give to the user.



