

BK

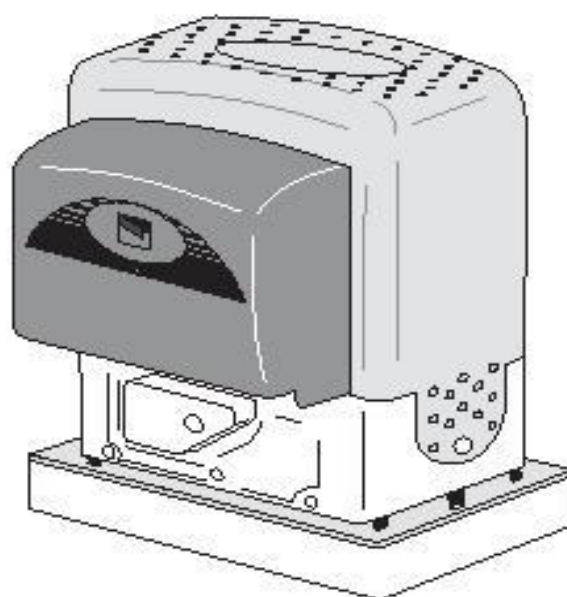

INSTALLATION MANUAL

BK 800 - 1200 - 1800 - 2200



BKE 1200 - 1800 - 2200

"IMPORTANT SAFETY INSTRUCTIONS FOR INSTALLATION"

"CAUTION: IMPROPER INSTALLATION MAY CAUSE SERIOUS DAMAGE, FOLLOW ALL INSTALLATION INSTRUCTIONS CAREFULLY"

"THIS MANUAL IS ONLY FOR PROFESSIONAL INSTALLERS OR QUALIFIED PERSONS"

1 Legend

-  This symbol indicates sections to be read with particular care.
-  This symbol indicates sections concerning safety.
-  This symbol indicates notes to communicate to users.

2 Destination and limits of use

2.1 Destination

The BK-BKE gearmotor is designed to automate sliding gates for residential and condominium complexes.

 The use of this product for purposes other than the one intended and installation carried out in a manner other than as instructed in this technical manual are prohibited.

2.2 Limits of use

Maximum gate weight 2200 kg with maximum length of 13 meters.

3 Standard followed

The following standard were complied with for this product: EN 12978, UNI EN 954-1, CEI EN 60335-1, UNI EN 12453.

4 Description

4.1 Gearmotor

The BK-BKE gearmotor is designed and built by CAME CANCELLI AUTOMATICI S.p.A. and it meets the safety standards in force. Guaranteed 24 months if not tampered with.

The case consists partly of cast aluminium, inside of which operates the non-reversible electromechanical gearmotor, and partly of a covering in ABS plastic inside of which is an electronic card and the transformer.

There are 4 versions of this unit:

- BK800 – automated unit with M4 pinion module, max capacity 800 kg;
- BK-BKE 1200/1210 – Automated unit with M4 pinion module, max capacity 1200 kg;
- BK-BKE 1800/1810 – Automated unit with M4 pinion module, max capacity 1800 kg;
- BK-BKE 2200/2210 – Automated unit with M6 pinion module, max capacity 2200 kg;

The BK-BKE gearmotor may be supplied with complementary accessories such as:

- 001 R001 - Lock cylinder with DIN keys;
- 001 BSF - Braking device for gates installed on a sloping surface;
- 001 BRC5/10/15 - Power supply cable winding device for sensitive safety profiles;
- 001 B4353 - Chain transmission device;
- 009 CGZ - Galvanized steel 22 x 22 module 4 rack;
- 009 CGZS - Galvanized steel 30 x 8 module 4 rack with fastening screws, holes and supports;
- 009 CGZ6 - 30 x 30 module M6 galvanized rack made of laminated steel for BK2200 and BKE2200 automated units;
- 009 CCT - Simple 1/2" chain;
- 009 CGIU - 1/2" chain joint.

Important! Check that the safety equipment and accessories are CAME originals; this is a guarantee that also makes the system easy to set up and upkeep.

4.2 Technical information

GEARMOTOR	WEIGHT	POWER SUPPLY	CURRENT	POWER	DUTY CYCLE	MAX TORQUE	REDUCTION RATIO	PUSH	MAX SPEED	CONDENSER	PROTECTION LEVEL	OPERATING TEMPERATURE
BK-800	21 Kg.	230 V a.c.	4,5 A	520 W	intensive service	* 28 Nm	1/31	800 N	10,5 m/min	22 µF	IP54	-20° C +55° C
BK-BKE 1200	18 Kg.	230 V a.c.	3,3 A	380 W	50%	* 31 Nm		850 N		25 µF		
BK-BKE 1210		120 V a.c.	5,6 A	310 W		* 42 Nm		1150 N		100 µF		
BK-BKE 1800	19,5 Kg.	230 V a.c.	4,2 A	480 W		* 40 Nm		1100 N		31,5 µF		
BK-BKE 1810		120 V a.c.	8 A	440 W		* 54 Nm		1500 N		140 µF		
BK-BKE 2200	21 Kg.	230 V a.c.	5,1 A	580 W		* 51 Nm		1400 N		35 µF		
BK-BKE 2210		120 V a.c.	9,1 A	500 W						160 µF		

* Obtained with CAME control panel.

All the data and information contained herein is considered subject to change at any time and at our discretion

4.3 Parts description

GEARMOTOR UNIT

- 1 - Gearmotor
- 2 - Board cover support
- 3 - End-stop flaps
- 4 - ZBK-ZBKE basic control board
- 5 - Electric board front cover
- 6 - Release door
- 7 - Base plate
- 8 - Securing screws
- 9 - Plates for securing screws
- 10 - Nuts

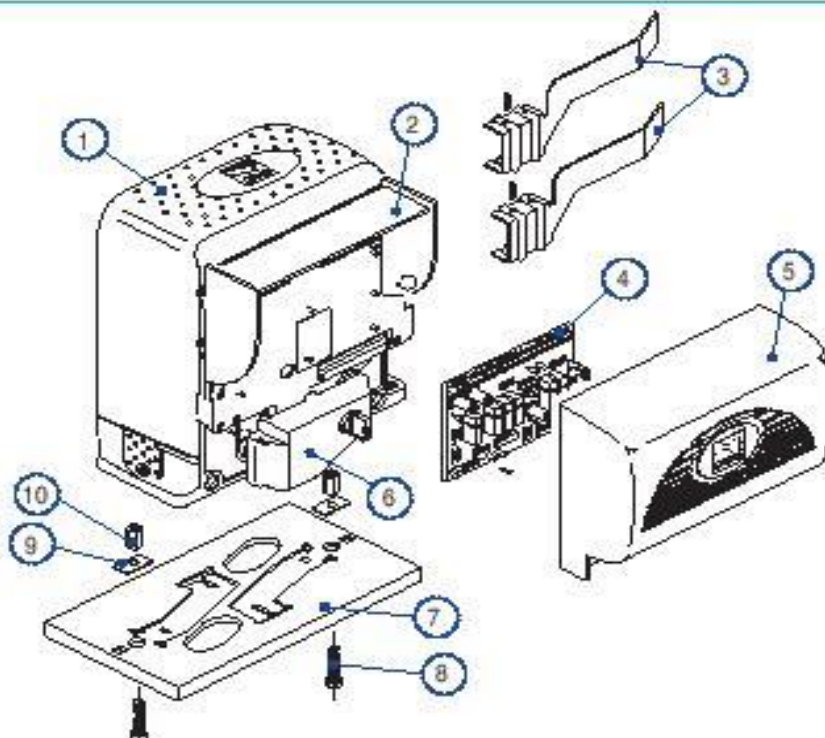

ACCESSORIES

- 1 - R001 - Cylinder lock with DIN keys
- 2 - BSF - Braking device
- 3 - BRC - Cable winding device
- 4 - B4353 - Chain transmission device
- 5 - CCT - Simple 1/2" chain
- 6 - CGIU - 1/2" chain joint
- 7 - CGZ - Galvanized steel 22 x 22 module 4 rack
- 8 - CGZS - Galvanized steel 30 x 8 module 4 rack with fastening screws, holes and supports
- 9 - CG26 - 30 x 30 module M6 galvanised rack made of laminated steel for BK2200 and BKE2200 automated units;

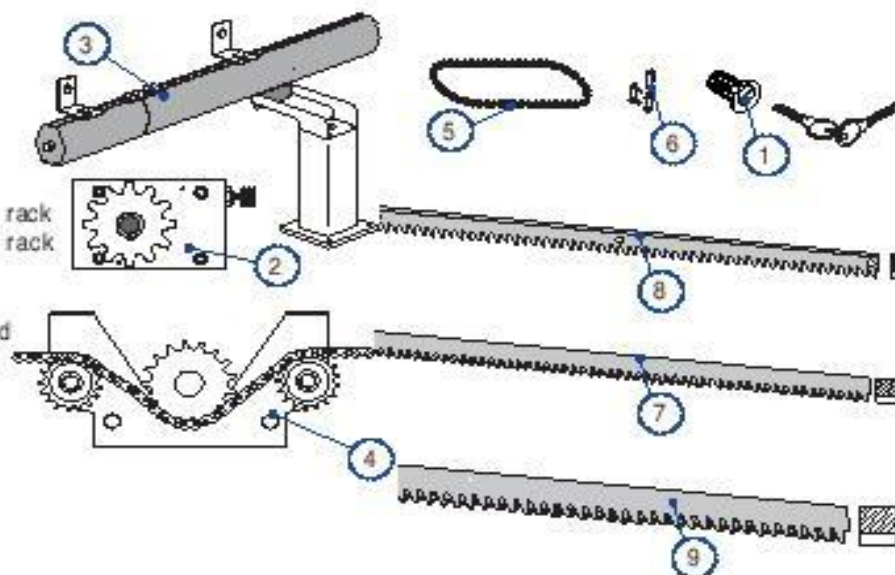

4.4 Overall dimensions

Measurements in mm

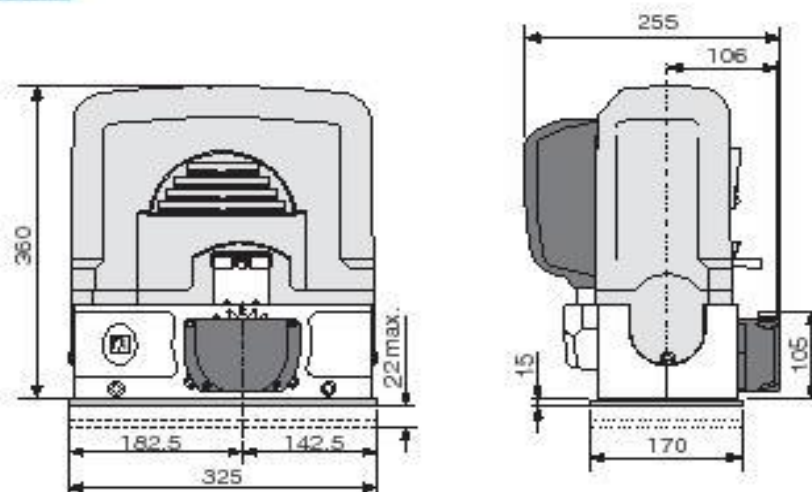

5 Installation

⚠ Only expert, qualified personnel must carry out the installation, in full compliance with the applicable law.

5.1 Preliminary checks

⚠ Before actually installing the gate operator, you are required to:

- Check that the leaf is rigid and compact and that the rollers are in good working order and properly greased;
- The gate track must be firmly set into the ground, above ground along its entire length and free of any foreign objects (debris) that may hamper the gate's movement;
- The top non-pinch rollers must not cause any friction;
- See to installing physical stops at fully-opened and fully-closed positions and the power supply line trench as per the standard installation;
- Make sure that the spot where the operator is mounted is located in an area that protects it from any impacts, and that the mounting surface be solid;
- See to installing a suitable all-pole disconnecter switch, with power isolation contacts more than 3mm apart from each other;
-  Connections inside of the casing made to provide continuity to the protection circuit are allowed, as long as they have additional isolation compared to other internal conductive parts;
- Set up suitable tubing and trenching to allow for electrical cables to pass, making sure they are free from any potential mechanical damage.

5.2 Tools and materials

Make sure you have all the tools and materials handy, to carry out the installation in total safety, according to the laws in-force. Below is a drawing of the tools you will need to install the operator.



5.3 Cable list and minimum thickness

Connections	Type of cable	Length of cable 1 < 10 m	Length of cable 10 < 20 m	Length of cable 20 < 30 m
120V-230V 2F power supply	FROR CEI 20-22 CEI EN 50267-2-1	3G x 1,5 mm ²	3G x 2,5 mm ²	3G x 4 mm ²
230V flashing lamp		2 x 0,5 mm ²	2 x 1 mm ²	2 x 1,5 mm ²
Photoelectric cells TX		2 x 0,5 mm ²	2 x 0,5 mm ²	2 x 0,5 mm ²
Photoelectric cells RX		4 x 0,5 mm ²	4 x 0,5 mm ²	4 x 0,5 mm ²
24V power supply accessory		2 x 0,5 mm ²	2 x 0,5 mm ²	2 x 1 mm ²
Control button		2 x 0,5 mm ²	2 x 0,5 mm ²	2 x 0,5 mm ²
Antenna connection	RG58	max. 50 m		

N.B.: An evaluation of the size of the cables with lengths other than the data in the table must be made based on the effective absorption of the connected devices, according to the instructions indicated by the CEI EN 60204-1 standards. For connections that require several loads on the same line (sequential), the size given on the table must be re-evaluated based on actual absorption and distances.

All the data and information contained herein is considered subject to change at any time and at our discretion

- | | |
|---|--|
| 1- BK or BKE unit | 6- Key-operated selector switch |
| 2- Control board incorporated | 7- Flashing light indicating door movement |
| 3- Radio receiver | 8- Antenna |
| 4- Limit-switch tabs (only for the BK unit) | 9- Safety photocells |
| 5- Rack | 10- Photocell column |
| | 11- Closure stop |

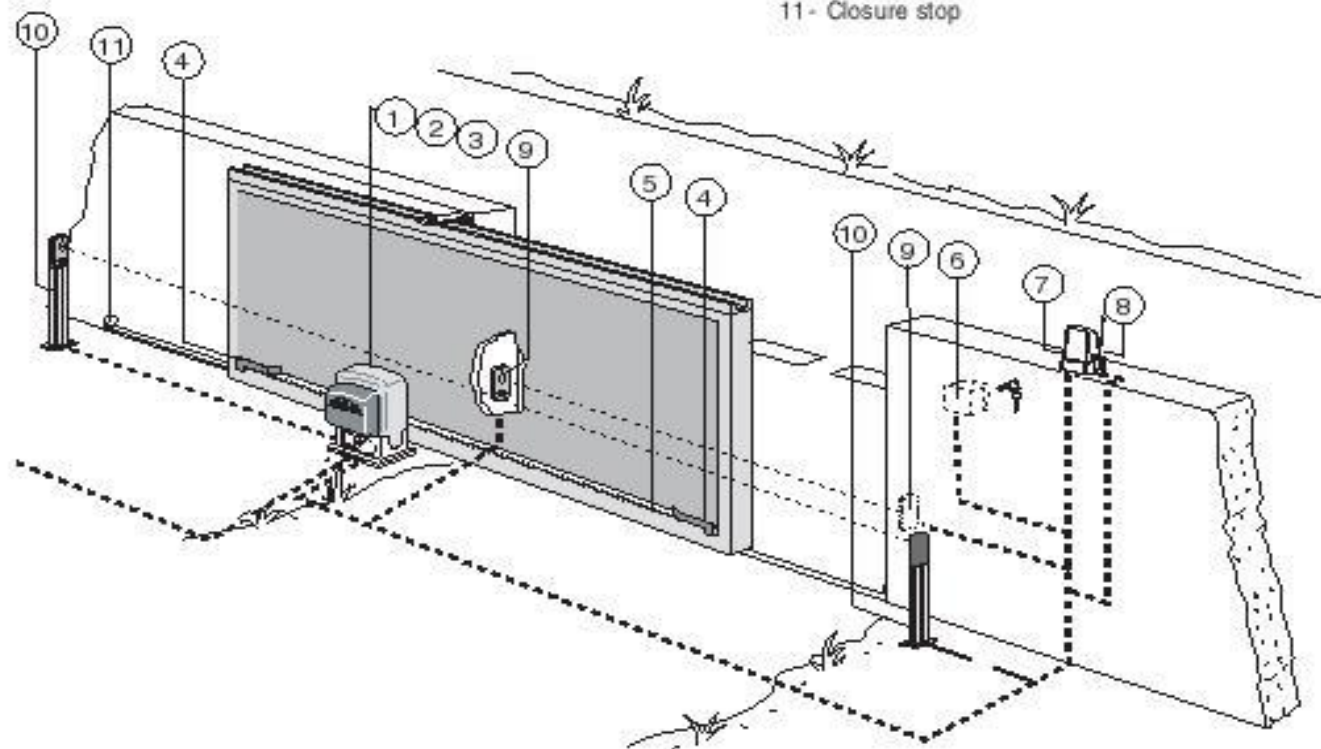

5.4 Motor to base anchorage

 The following applications are only examples, as the space required for unit installation and the accessories vary depending on dimensions and therefore it is up to the installer to select the best solution.

Install the screws in the anchor plate and fasten them with a nut, then bend the preformed clamps downwards. Construct a cement foundation that is large enough to accommodate the gear motor (it is a good idea to protrude 50 mm. from the ground). When pouring the foundation, embed the gear motor anchor plate and the relative clamps in the cement. The anchor bolts should be embedded in the concrete in the positions indicated; the drive unit is then attached to this bolts. The anchor plate must be perfectly level and absolutely clean; the bolts threads must be completely exposed.

N.B.: The flexible tubes for the electrical wiring must be embedded in the base and protrude in the correct position.

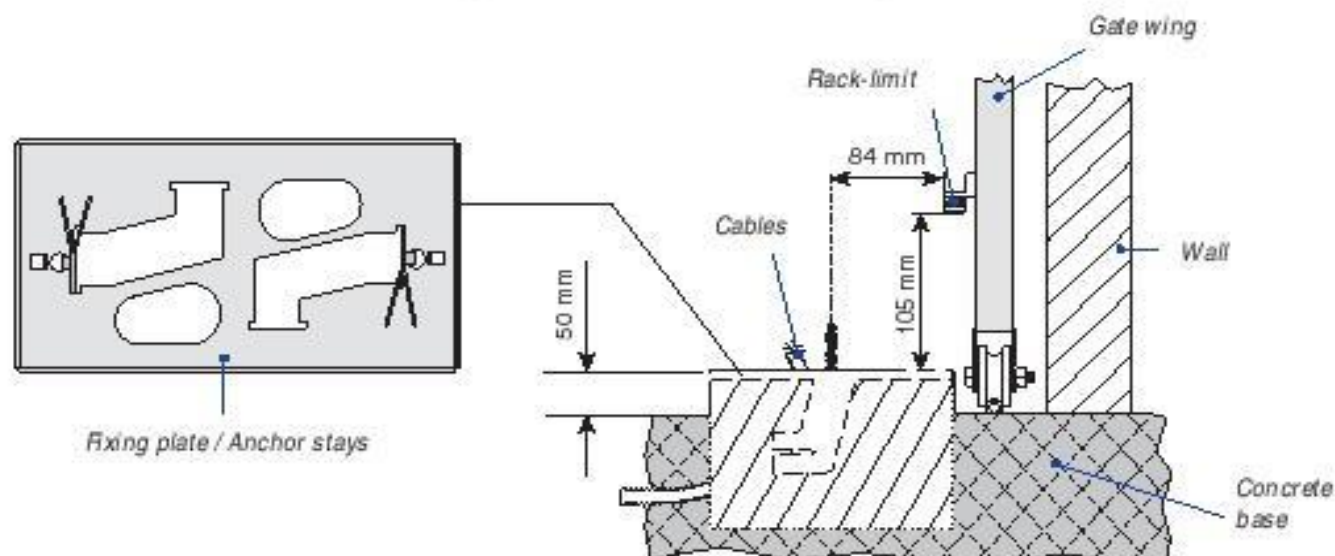

5.5 Unit installation

During the initial phase of installation, the feet should protrude by 5-10 mm. in order to allow for alignment, anchorage of the rack and further adjustments.

Perfect alignment with the guide rail is made possible by the (patented) built-in regulation system, which consists of:

- slots for horizontal adjustment;
- threaded steel feet for vertical adjustment and levelling;
- plates and bolts for anchorage to the base.

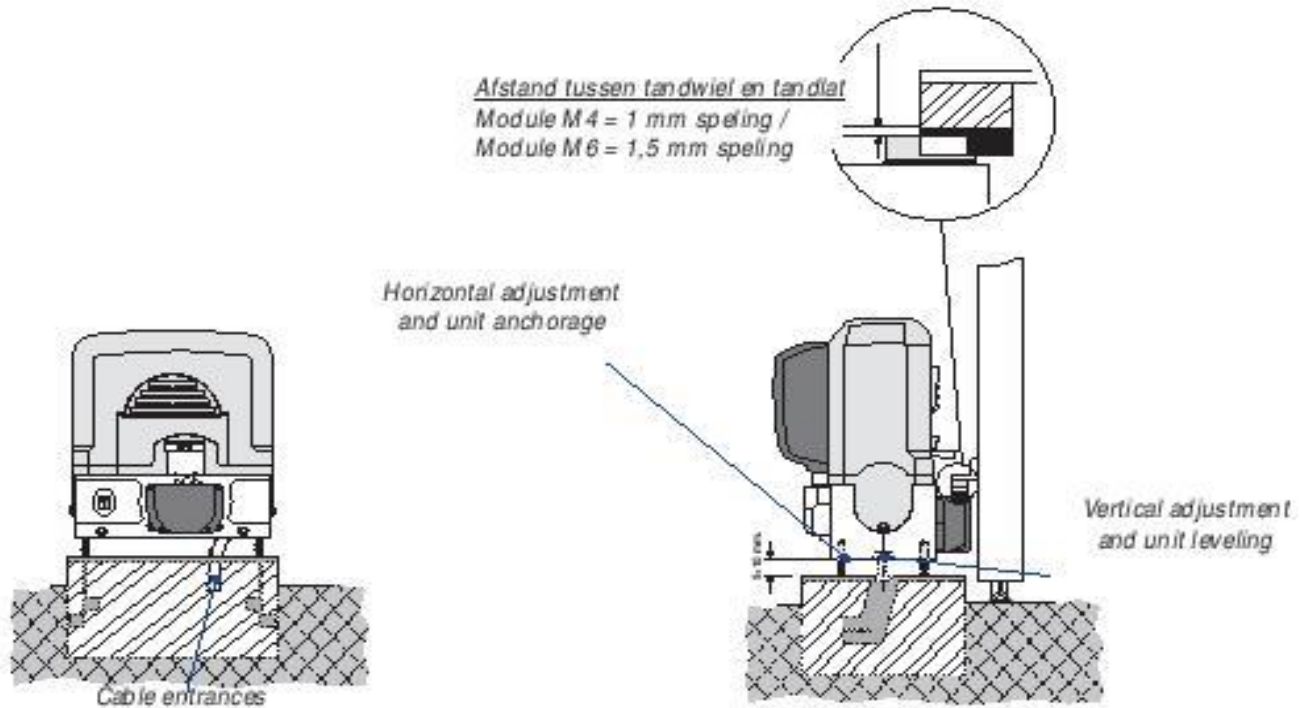

5.6 Attaching the rack/limit

Attach the rack to the gate as described below:

- Release the gearmotor (parag. 5.8);
- position the rack on the pinion of the gearmotor and slide the gate manually in order to attach the rack along its entire length;
- when the rack is attached to the gate, adjust the feet using a screwdriver until the play between the pinion and the rack is correct (1-2 mm.).

N.B.: This position ensures that the weight of the gate does not rest on the gearmotor.

- If the rack is already attached, proceed directly to the adjustment of the rack/pinion coupling.
- when the necessary adjustment have been completed, fasten the unit in position by tightening the two anchor bolts.

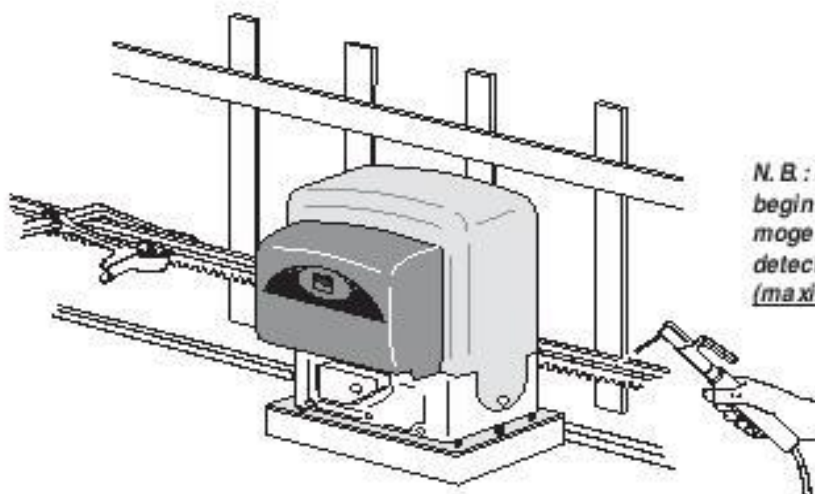

N.B.: op het model BKE moet men de tandlat beginnen installeren in de helft. Dit om het mogelijk te maken dat de ENCODER de afstand detecteert
(maximum looplengte hekken = 13 m)

5.7 Attaching the switch tabs (BK series)

Position the limit-switch tabs (whose positions determine the limits of gate travel) on the rack.

Note: do not allow the gate to strike the mechanical stops in the open or closed positions.

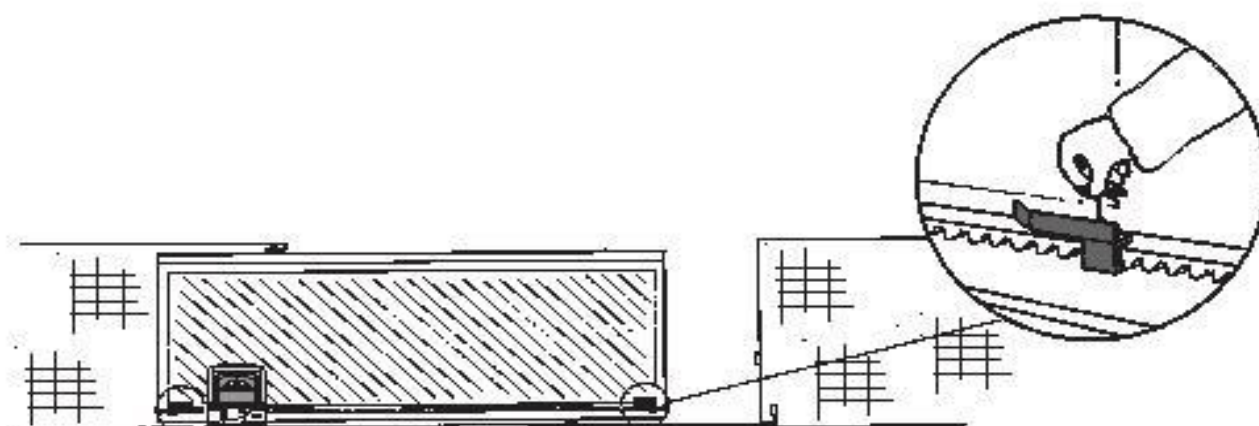

5.8 Manual release of the gearmotor

To open the access door, insert the key A, push down and rotate clockwise. Then release the ratio motor by using key B on the three-lobed pin and turning it in the direction indicated.

To re-lock the reduction gear, turn key B in the direction indicated until it will move no further, without forcing it; the three-sided pin will settle into place at the first movement.

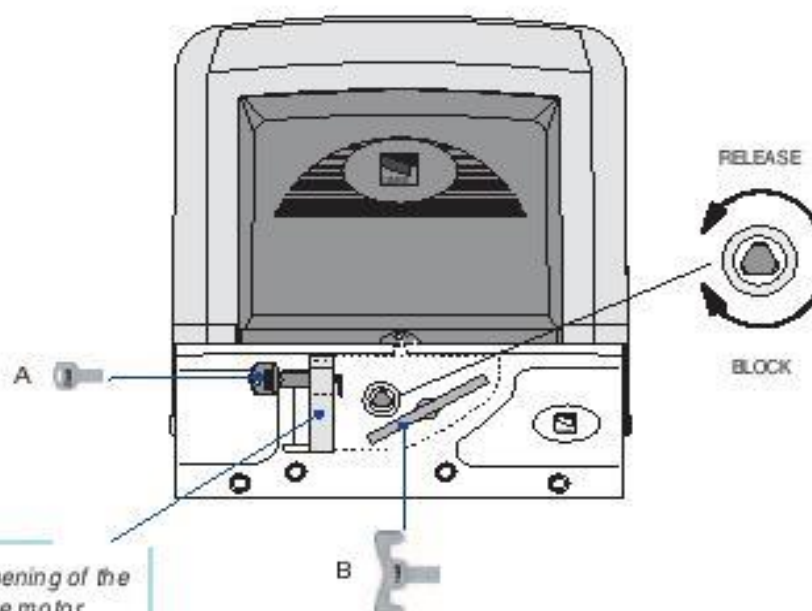

⚠ ATTENTION: the opening of the unblock panel arrests the motor.

6 Control board

6.1 Technical description

The control board is powered with (120V a.c. or 230V a.c.) across terminals L and N and is protected by fuse on the main power line (see table).

The control systems are powered by low voltage (24V) and protected by a 1A fuse.

The total power consumption of the 24V accessories must not exceed 20W.

The operating time (interval) is fixed at 150 seconds.

The photocells can be connected and set to re-open during the closing phase, re-open during the opening phase, partial stop, total stop and obstacle sensing when motor is not running.

Note: if a normally closed safety contact (2-C1, 2-CX or 1-2) is opened, this is indicated by the flashing LED (ref. point 9, main components).

The ZBKE board autonomously controls a safety function that senses any obstacles which:

- when opening, stops the gate and triggers automatic closing;
- when closing, inverts the direction of movement of the gate until it is fully opened and consequently, automatically closes it.

Warning! After the gate's direction is inverted three consecutive times, the gate remains opened excluding the automatic closing function – use the remote control or push button to close the gate.

The board also includes other selectable functions, such as: automatic closing, partial opening, pre-flashing of the opening and closing phases, "maintained action movement", phase or courtesy lamp, partial stop or re-closing during opening phase, master-slave and the following command: open-stop-close-stop, open-close-inversion or only open.

The automatic closing and partial opening times are adjustable.

Warning! Before doing any work inside of the unit, shut off the power supply.

6.2 Main components

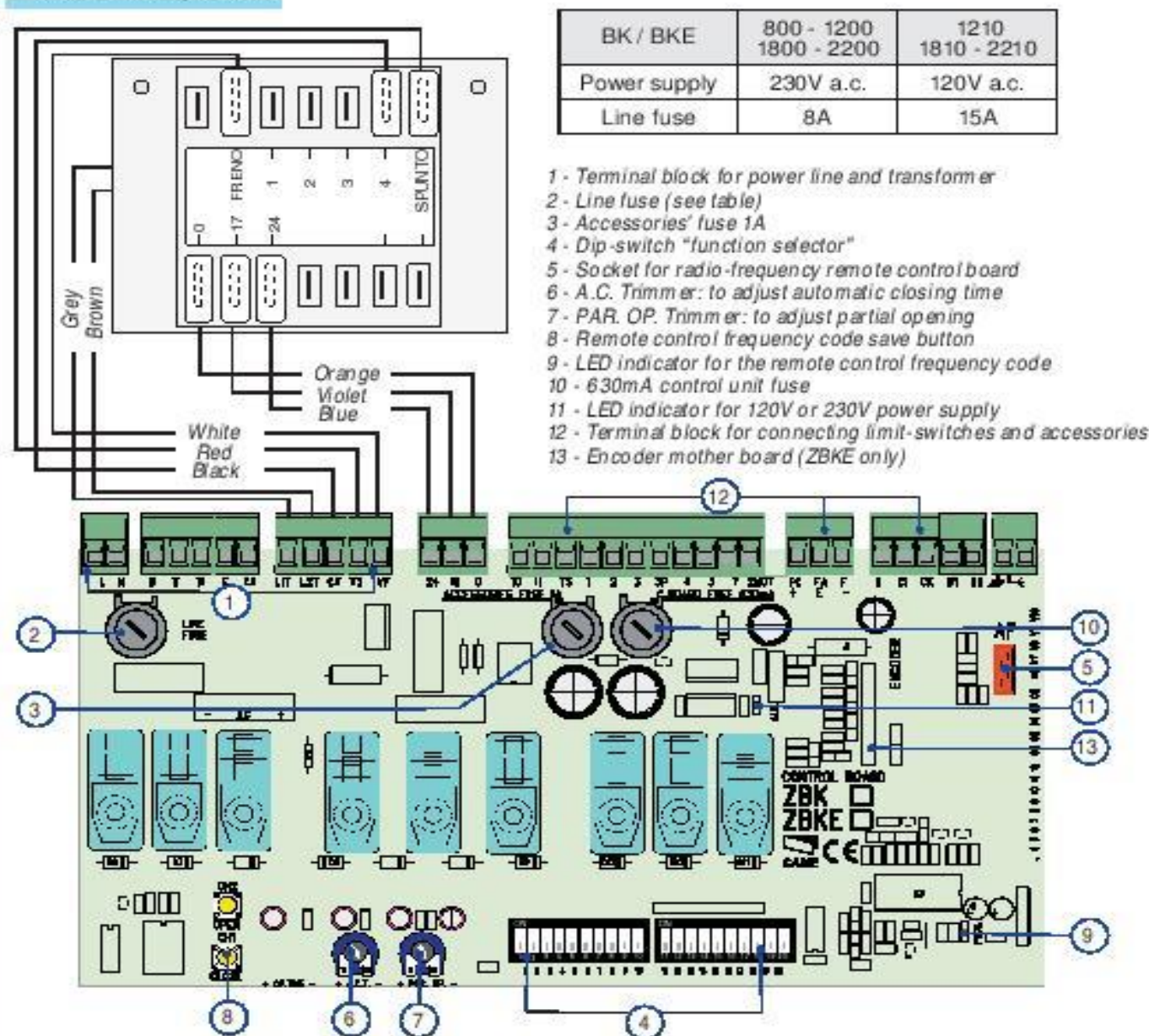

6.3 Electrical connections

Connection for gear motor, limit switch or encoder

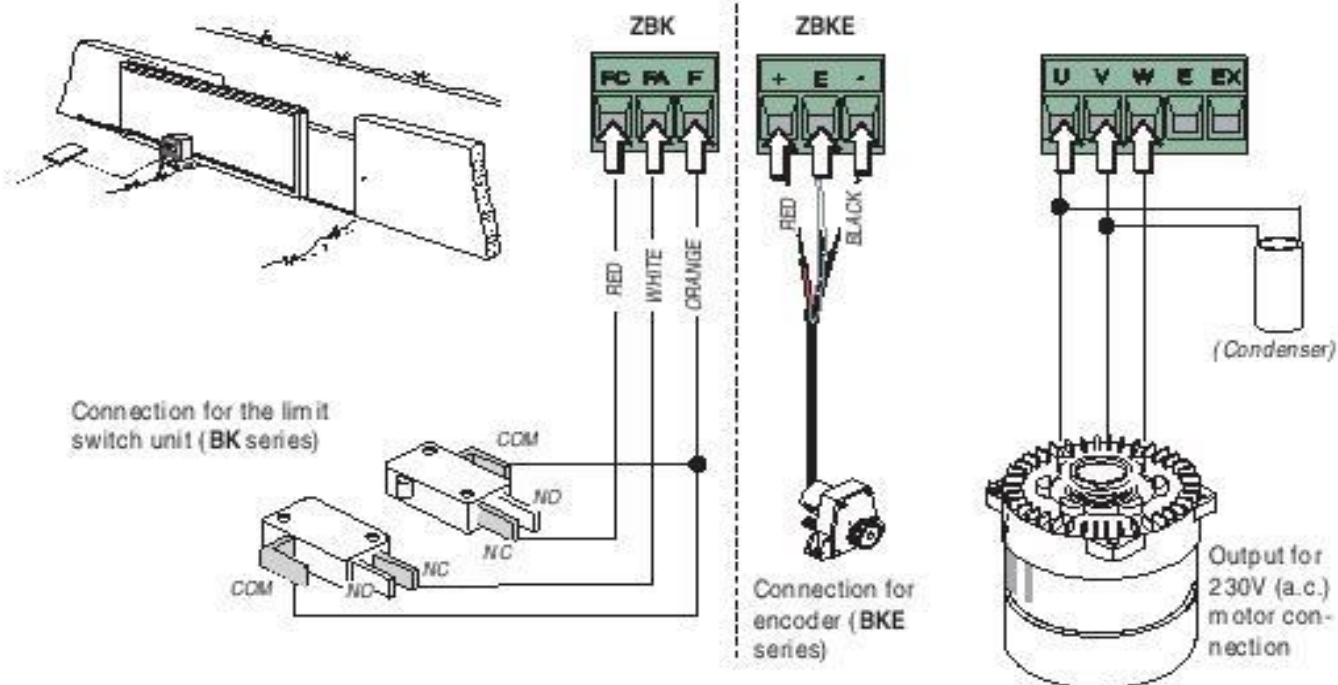

Modifications to the connection if installing the gear motor on the right side

- Invert the phases of the gear motor (U; V);
- On the BK series, invert wires (FA; FC);
- On the BKE series, invert the wires of the shielded cable (+; -)

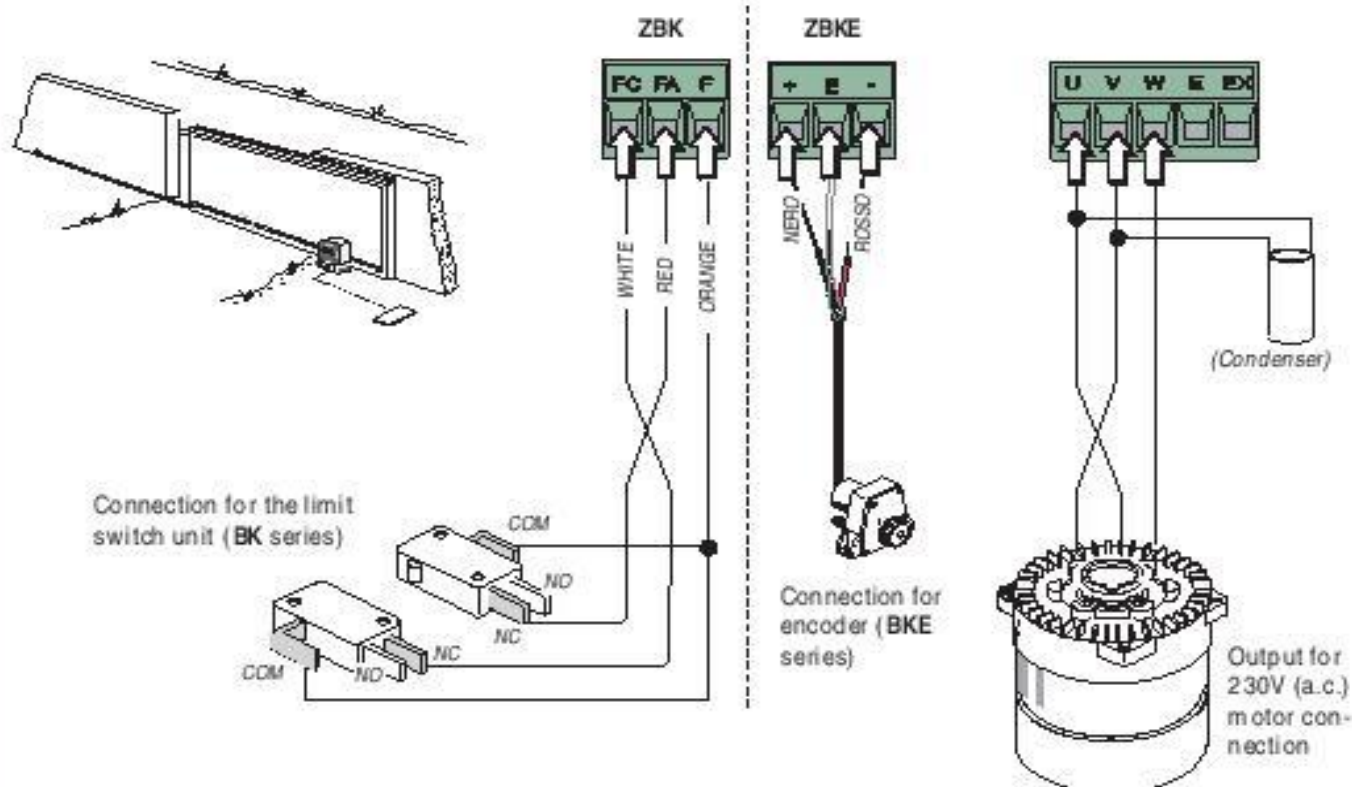

Connections to the systems

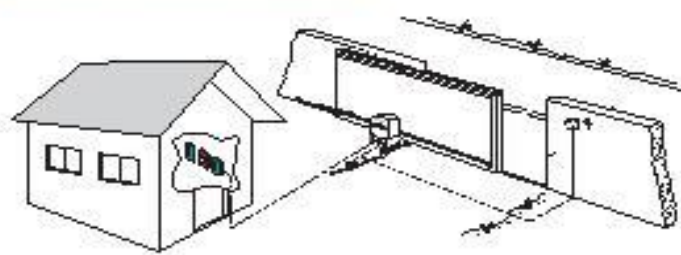

Stop button (N.C. contact) – Gate leaf stop- button with exclusion of automatic closing phase, resume motion by pressing the push button or remote control.

Key selector and/or opening button (N.O. contact) – Opens the gate leaf.

Key selector and/or partial opening button (N.O. contact) - Opens the gate leaf for pedestrian access (adjustable using the trimmer PAR.OP.)

Key selector and/or closing button (N.O. contact) – Closes the gate leaf.

Key selector and/or commands button (N.O. contact) – opens and closes the gate leaf, by pressing the button or turning the key on the selector, the gate leaf inverts its direction of motion or stops depending on the chosen selection made on the dip-switches (see selecting functions, dips 2 and 3).

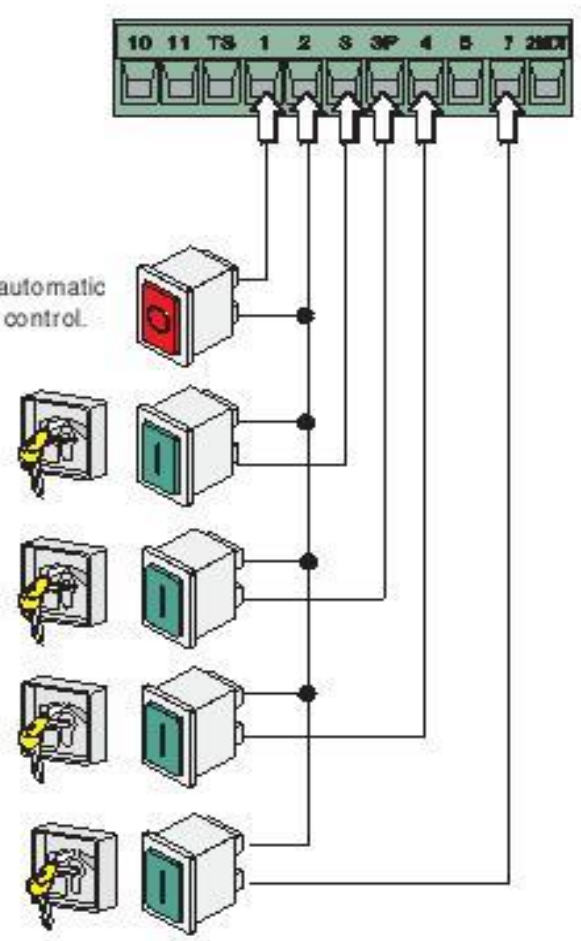

Connections to warning and illumination devices

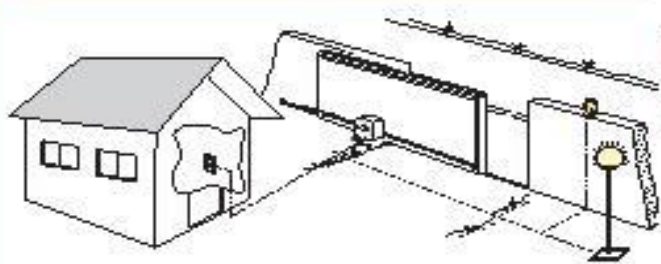

Courtesy lamp (Contact output: 230V – 60 W max.)
 – Auxiliary connection for suitably positioned external lamp to increase lighting of the steering area. It remains lit for a fixed time of 5 minutes and 30 seconds.
DIP 16 ON – DIP 17 OFF
 (not included in the BK800 version)

Phase lamp (Contact output: 230V – 60W max.)
 – Auxiliary connection for a suitably positioned external lamp, to increase lighting of the steering area. It stays on from the moment the gate leaf starts to open until it is fully closed (including the automatic closing time). If the automatic closing function is inserted, the light stays on only while gate is moving.
DIP 17 ON – DIP 16 OFF
 (not included in the BK800 version)

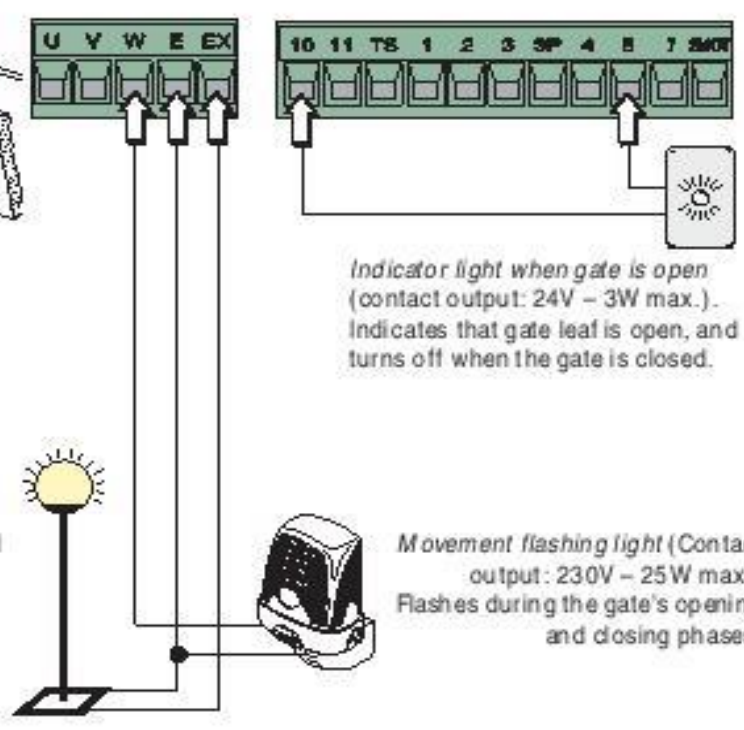

Indicator light when gate is open (contact output: 24V – 3W max.)
 Indicates that gate leaf is open, and turns off when the gate is closed.

Movement flashing light (Contact output: 230V – 25W max.)
 Flashes during the gate's opening and closing phases.

All the data and information contained herein is considered subject to change at any time and at our discretion

Connections to safety devices (DIR photocell)

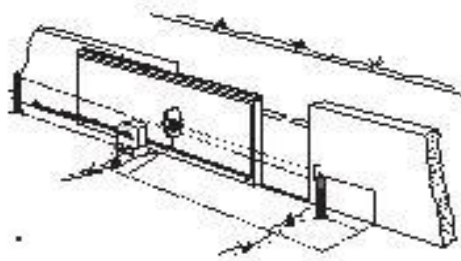

(N.C.) contact for "re-opening during closing"
 – Input for safety devices such as photocells, sensitive safety edges and other devices compliant with EN 12978 standards. When the gate leaf is closing, opening the contact triggers the inversion of the direction of movement until the gate leaf is fully open.

(N.C.) contact for "partial stop" – Input for safety devices such as photocells, sensitive safety edges and other devices compliant with EN 12978 standards. If in motion, the gate leaf stops, and automatic closing is consequently triggered. **DIP 8 OFF – DIP 9 ON.**

(N.C.) contact for "re-closing during opening phase"
 – Input for safety devices such as photocells, sensitive safety edges and other devices compliant with EN 12978 standards. When gate is opening, if the contact is opened it triggers an inversion of the direction until gate is fully closed. **DIP 8 OFF – DIP 9 OFF.**

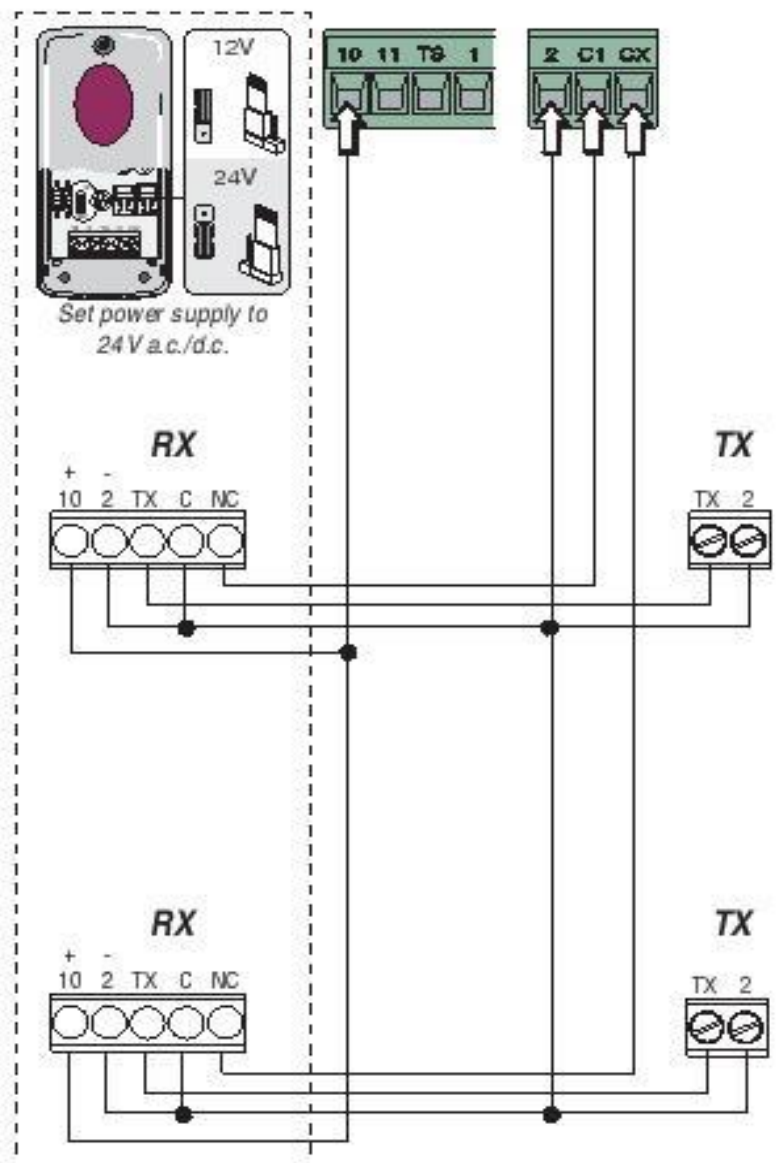

Set power supply to 24V a.c./d.c.

Connections for power source and accessories

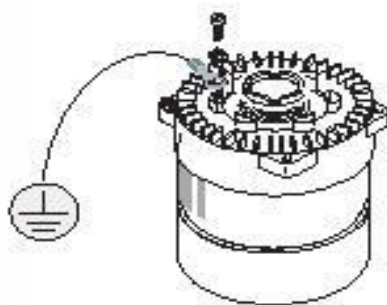

Eyelet cable terminal with screw and washer for ground connection

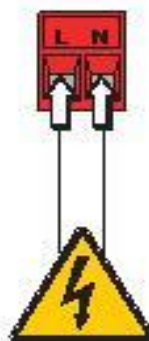

Electric power 120V – 230W (a.c.) – 50/60 Hz

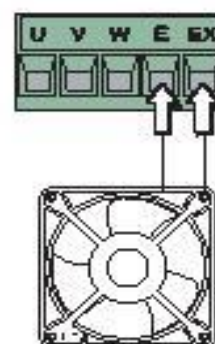

Fan (contact output: 230V – 25W) – Connection for the fan which cools the gear motor. Each time the gate leaf is opened, the fan stays on for a fixed time of 5 minutes and 30 seconds. **DIP 16 ON – DIP 17 OFF (only for the BK800 version)**

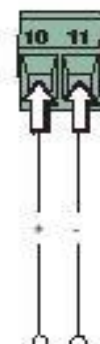

24V (d.c.) output to power accessories (20W max.)

6.4 Electrical connection for the check of the operating state of the photocells

(DIR)

(DOC)

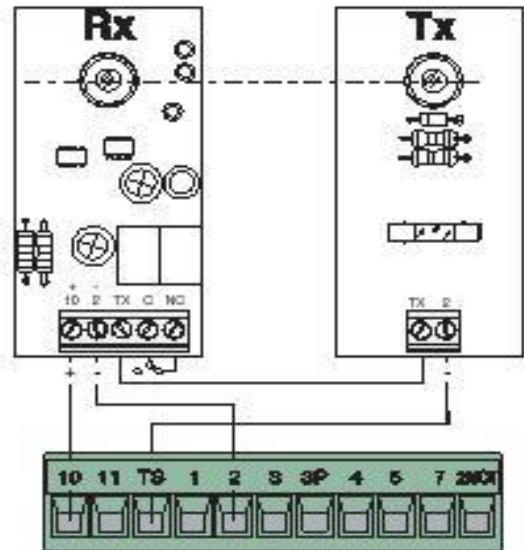
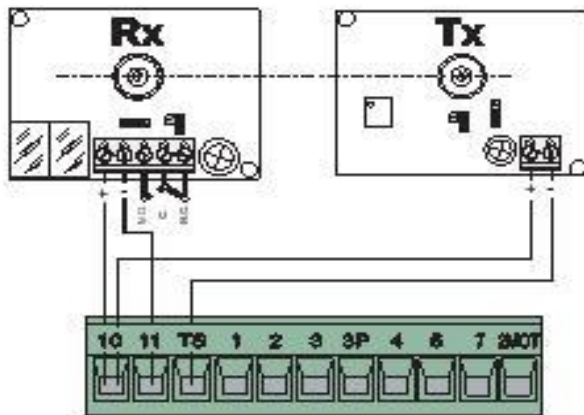

Each time an open or close command is given, the circuit board checks the efficiency of the safety devices (i.e. photocells). The flashing led indicator on the control panel indicates an anomaly of the photocells (Ref. to point 9, p. 8), consequently it cuts off any command from the remote control or push button.

Electrical connection to test the state of the safety check of the photocells:
 - the transmitter and receiver, must be connect as shown in the drawing;
 - select dip 13 to ON to activate the test function.

IMPORTANT:

When running the safety test function, exclude the N.C. contacts, if not used, by acting on their corresponding DIPs (see para. 6.7 selecting functions).

6.5 Motor torque limiter

To vary the motor torque, move the faston indicated by the black wire (connected to terminal CT) to one of the 4 positions:
 1 min ÷ 4 max.

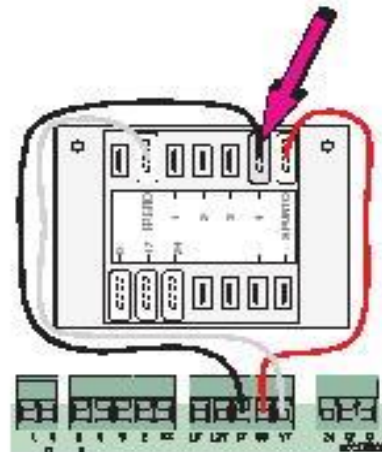

6.6 Adjustments



A.C.T. Trimmer = Automatic Closing Time. This adjusts the gate's stand-by time in the opening phase, a.k.a. "pause time". When the time elapses the gate automatically closes. The "pause time" can be adjusted from 1 second to 150 seconds.

PAR. OP. Trimmer = Partial opening. Adjusts the gates opening time. By pressing the partial opening button on 2-3P, the gate will open for a pre-set time of between 1 and 14 seconds.

With this function, the automatic closing time will vary as follows:

- when dip 12 is set to ON, after a partial opening, the closing time is independent of the A.C.T. Trimmer adjustment and of the setting of DIP 1, and is set to 8 seconds;
- when dip 12 is set to OFF, after a partial opening, the automatic closing time is adjustable only if dip 1 is set to the ON position.

6.7 Selecting functions (dip-switch)



- 1 ON - *Automatic Closing* – the automatic closing timer is automatically triggered at the end of the opening phase. The adjustable set time of operation, is in any case subordinate to the operation of any safety accessories and is excluded after a total "stop" phase or if the main power is cut off.
- 2 ON - *"Open-stop-close-stop"* function with button (2-7) and remote control (that has a radio frequency board inserted).
- 2 OFF - *"Open-close-inversion"* function with button (2-7) and remote control (that has a radio frequency board inserted).
- 3 ON - *"Open only"* remote control (that has a radio frequency board inserted).
- 4 ON - *"Maintained action" function* – Gate operation by keeping the opening button pressed on 2-3, and the closing button 2-4, (it excludes the remote control from operating).
- 5 ON - *Pre-flashing in opening and closing phase* – Following a command to open or close, the flashing device connected to W-E1, flashes for 5 seconds before gate movement begins.
- 6 ON - *Obstacle sensor* – When the motor is not running (i.e. the gate is closed, open or following a total stop command), it prevents any movement of the gate if the safety devices (e.g. the photocells) sense an obstacle in the way.
- 7 OFF - *Reopening during the closing phase* – When the photocells sense an obstacle as the arm is closing, they trigger an inversion of direction movement until full opening is achieved; insert the safety device into terminal (2-C1); if not used, set dip switch to ON.
- 8 OFF / 9 OFF - *Re-closing during opening phase* – When the photocells sense an obstacle in the way during the gate's opening phase, they trigger an inversion of movement direction until the gate is fully closed; insert safety device into terminal (2-CX);
- 8 OFF / 9 ON - *Partial stop* – The gate stops completely when moving consequently triggering the automatic closing, insert the safety device into terminal (2-CX); **(if the devices on 2-CX are not used, set dip switch 8 to the ON position)**
- 10 OFF - *Total stop* – This function stops the gate and consequently excludes any automatic closing phase; for movement to begin again press button or remote control. Insert the safety device into (1-2); if not used, set dip switch to the ON position.



- 11 OFF - *"Slave" function* deactivated, the board is exclusively piloted by the "master" (to be activated only for coupled connection, see p.15);
- 12 ON - *Partial opening function* (the automatic closing is fixed to 8");
- 12 OFF - *Partial opening function* (the automatic closing is adjustable through the trimmer, if inserted);
- 13 ON - *Functioning of the photocells' safety test* – Enables the control unit to test the efficiency of the safety devices (e.g. photocells) after each opening or closing command;
- 14 OFF - *"Master" function* deactivated, the board takes over all the control functions as concerns two coupled motors (to be activated only for coupled connection, p. 15);
- 15 ON - *"Spare" function* for programming the limit switch (only for the ZBKE series, p. 14);
- 16 ON / 17 OFF - *Courtesy lamp function* activated; (16 OFF deactivated)
- 17 ON / 16 OFF - *Phase lamp function* activated; (17 OFF deactivated)
- 18 Not connected
- 19 Not connected
- 20 Not connected

7 Programming of limit switches for ZBKE board

1) Close the engage door-panel and insert DIP switch 15 to the ON position, the led indicator of the radio code starts flashing.

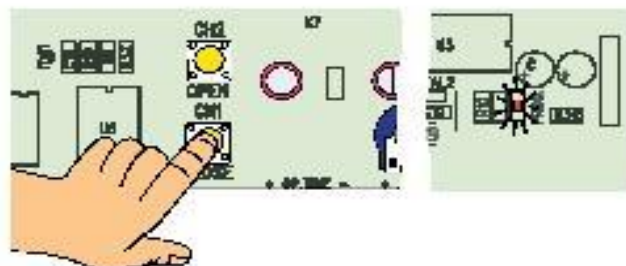
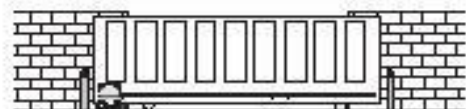
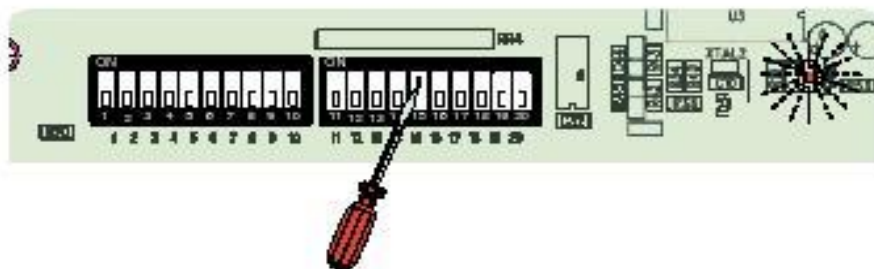

2) Manually close the gate leaf, press the "CLOSE" button, the led indicator keeps flashing as long as button is kept pressed.

3) Manually open the gate leaf, press the "OPEN" button, the led code indicator keeps flashing as long as the button is kept pressed.

N.B.: By pressing the "OPEN" button during this procedure, the led indicator does not turn on; invert the phases of the motor (U; V) and of the Encoder (+; -), see para. 6.3 electrical connections of the motor and encoder, p. 9.

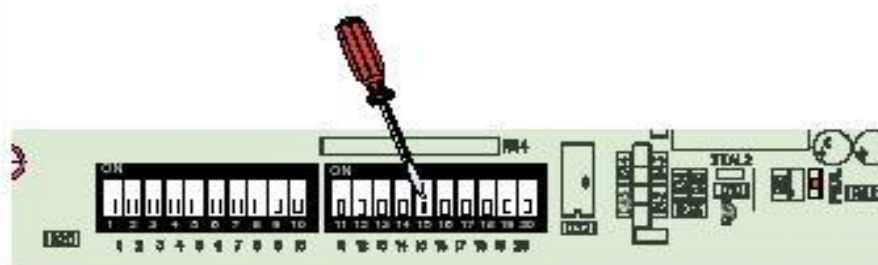
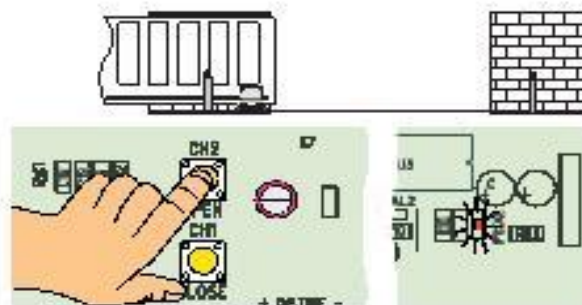

4) Re-set DIP switch 15 to the OFF position.

5) When the programming procedure is finished, open the door panel and block the gear motor with key B by turning it in the indicated direction and close the door panel.

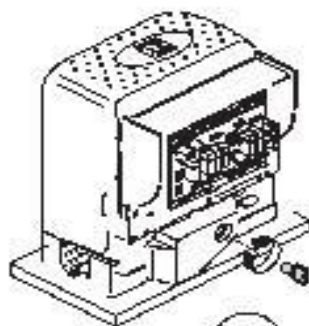

1

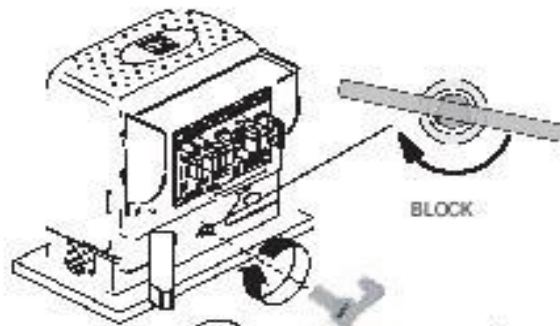

2

8 Connection of two coupled gear motors with single control

1) Coordinate the direction of gear motors "A" and "B", by changing the rotation of motor "B" (see connection for the gear motor and limit switches, p. 9).

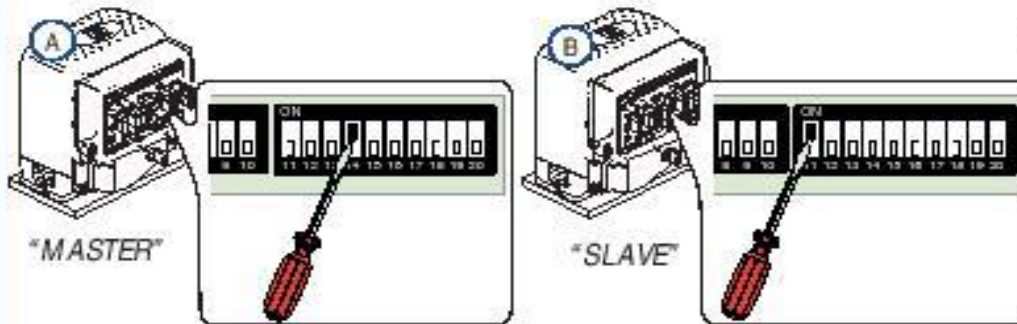
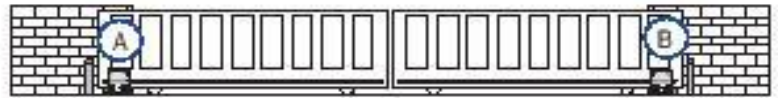

2) Establish which motor, "A" or "B" will be the master (or pilot), set dip switch 14 to the ON position on the control board. "Master" means the motor that controls both gates, while on the control board of the 2nd motor, position dip switch 11 to the ON position to place it into a "slave" state.

N.B.: Make sure that the radio-frequency board is inserted only into the Master board.

3) Wire the electrical connections and the normally used selections only on the MASTER terminal board:

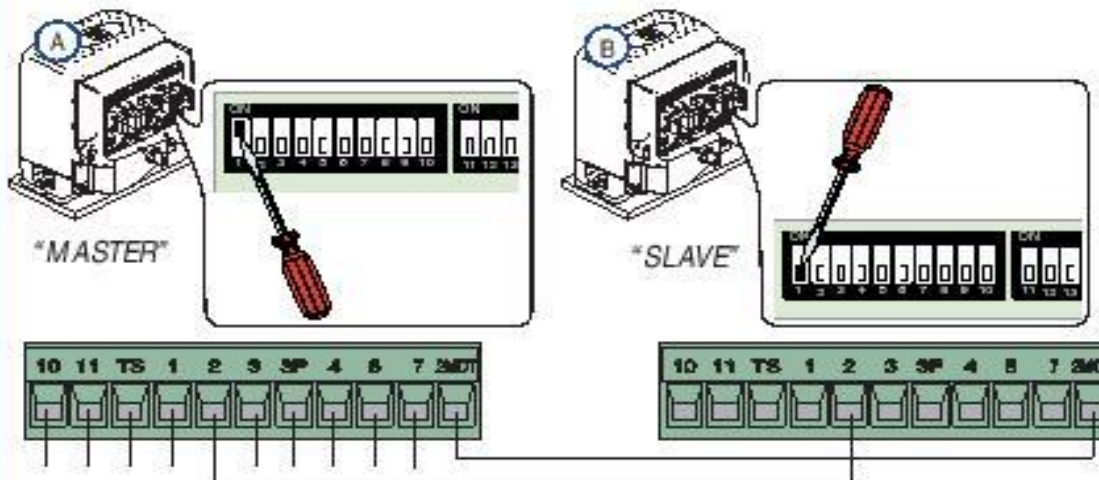
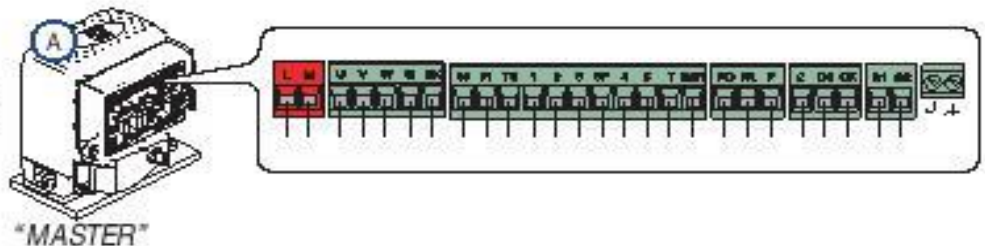

4) Wire the electrical connections between the terminal boards, as shown in the figure.

Note: make sure that the automatic closing is triggered by the master and deactivated in the slave.

5) Make sure that all the dip switches on the board of motor 2 are OFF, except for dip switch 11.
Important: adjust the limit switches of the motors so that the MASTER motor's gate leaf closes after that of the SLAVE.

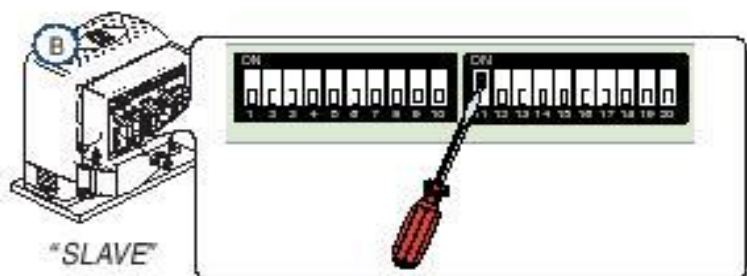

9 Installation procedure of the transmitter for remote control

Input for the remote control's antenna
 - For opening and closing of the gate leaf using the remote control. Connect the RG58 cable to the terminal of the antenna with "AF" radio-frequency inserted in the motherboard.

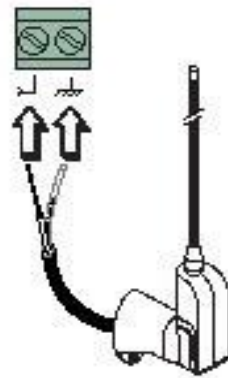

Possible second channel output from the radio receiver (contact N.O.) Contact output: 5A-24V (d.c.).

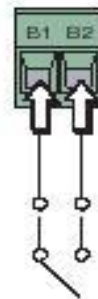

Read the three steps below before beginning installation procedures:

- prepare the radio board (paragraph 9.1);
- procedure for codifying the transmitter (paragraph 9.2);
- memorizing the code on the command board (paragraph 9.3).

9.1 Prepare the radio board AF

1) On AM transmitters operating at 433.92 MHz (TOP and TAM series), position the jumper connection on circuit card AF43S as shown on the sheet.

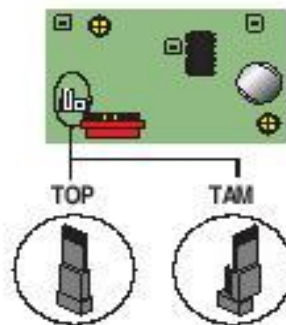

Frequency/MHz	Radio frequency board	Transmitter
FM 26.995	AF130	TFM
FM 30.900	AF150	TFM
AM 26.995	AF26	TOP
AM 30.900	AF30	TOP
AM 433.92	AF43S / AF43SM	TAM / TOP
AM 433.92	AF43SR	ATOMO
AM 40.685	AF40	TOUCH

2) The AF board must ALWAYS be inserted into the coupling (ref. point 5, page 8) when the power is off because the motherboard only recognises it when it is powered.

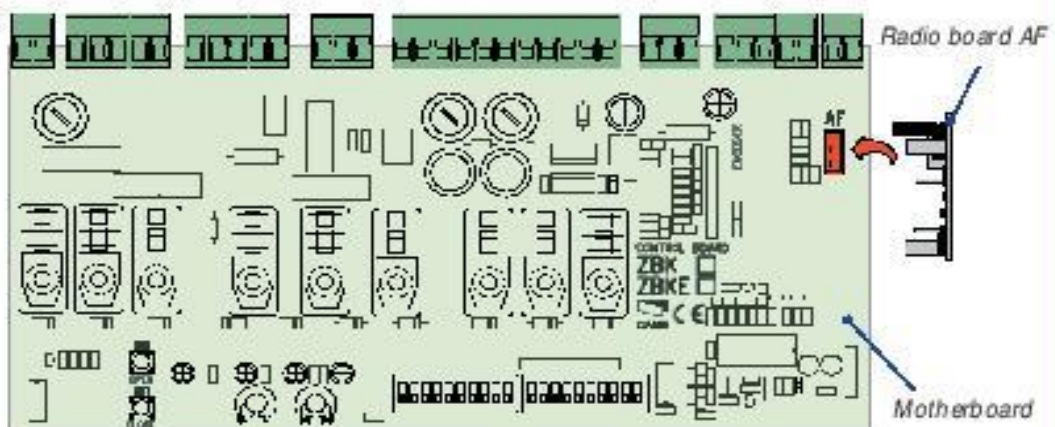
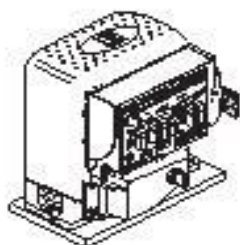

9.2 Procedure for codifying the transmitter

TOP SERIES

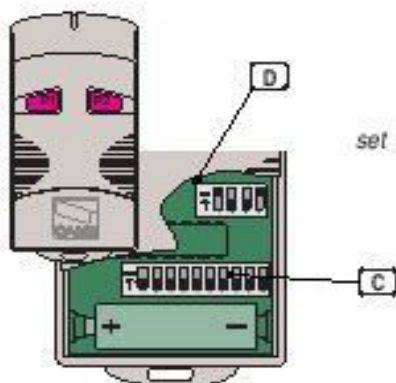

TOP T432M - T312M

set the code to dip-switch C and channel to D (P1=CH1 and P2=CH2, default setting)

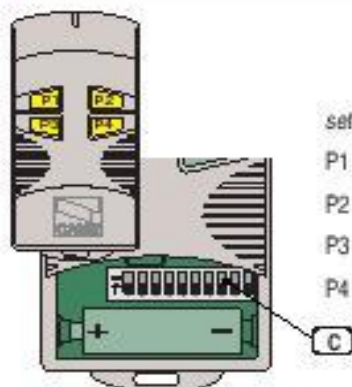
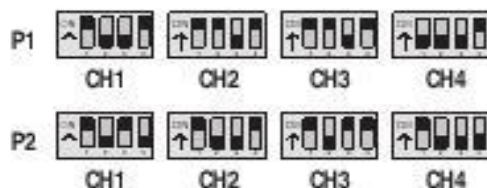

TOP T434M - T314M

set code only

- P1 = CH1
- P2 = CH2
- P3 = CH3
- P4 = CH4

TOP T432S - T432SA - T434MA - T432NA - T434NA

see instructions on pack



TAM T432 - T434 - T438 - TAM432SA

see instruction
sheet inside the
pack

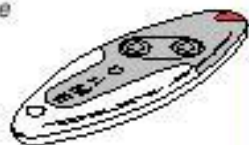

TFM T132 - T134 - T138 T152 - T154 - T158

see instruction sheet inside the
pack

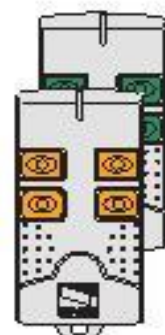

TOP QUARTZ SERIES

Standard encoding procedure T262M - T264M - T2622M - T302M - T304M - T3022M

1 assign a code (also on file)

P1	<input type="checkbox"/>	<input type="checkbox"/>	<input type="checkbox"/>	<input type="checkbox"/>	<input type="checkbox"/>	<input type="checkbox"/>	<input type="checkbox"/>	<input type="checkbox"/>	<input type="checkbox"/>	<input type="checkbox"/>	OFF
P2	<input type="checkbox"/>	<input type="checkbox"/>	<input type="checkbox"/>	<input type="checkbox"/>	<input type="checkbox"/>	<input type="checkbox"/>	<input type="checkbox"/>	<input type="checkbox"/>	<input type="checkbox"/>	<input type="checkbox"/>	ON
	1	2	3	4	5	6	7	8	9	10	

2 connect encoding jumper J

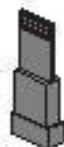

3 register code



Press P1 or P2 in sequence in order to register the code; at the tenth pulse, a double beep will confirm that registration has occurred

4 disinsertre jumper J

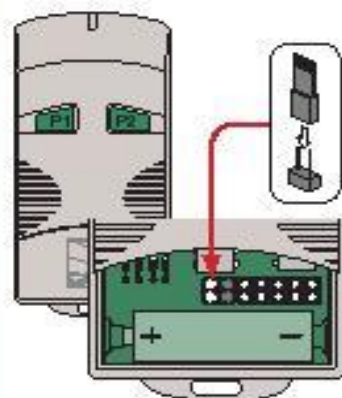

TOP
T262M - T302M

The first encoding operation must be carried out whilst keeping the jumpers positioned for channels 1 and 2 as per fig. A; see fig. B for any subsequent settings on different channels.

FIG. A

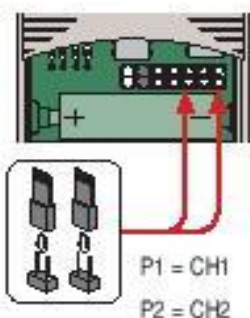
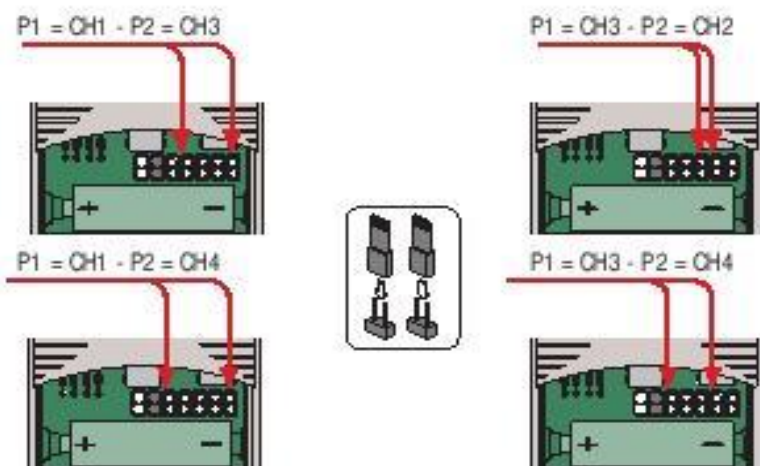
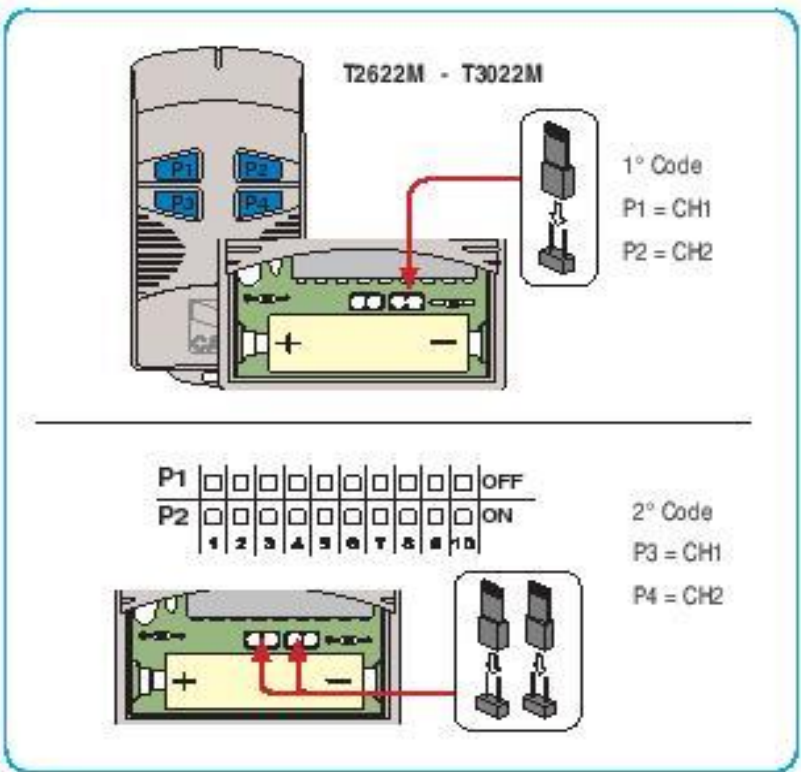
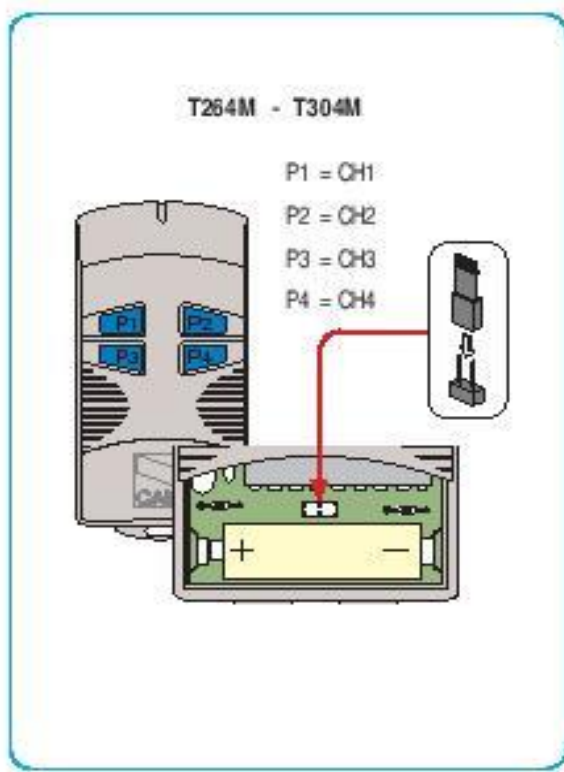
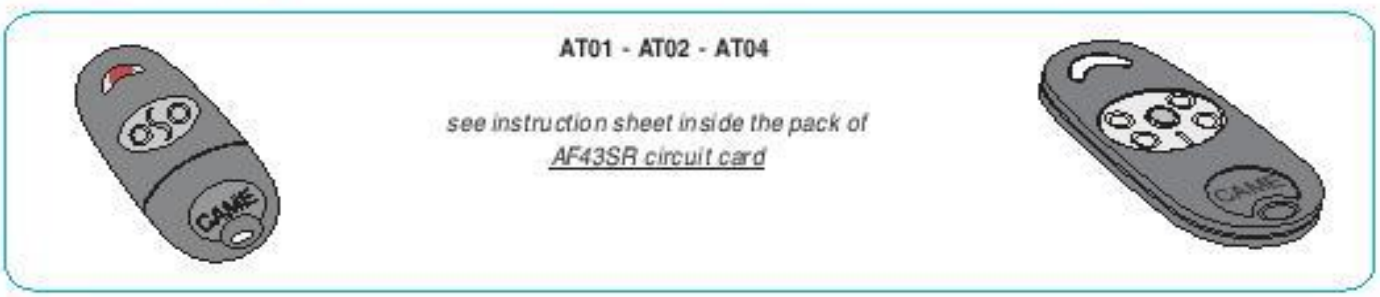

FIG. B





ATOMO SERIES



TOUCH SERIES



9.3 Memorizing the code on the command board



CH1 = Channel for direct commands to a function of the ratiomotor control unit ("open only" / "open-close-invert direction" commands or the "open-stop-close-stop" command, depending on dip-switch 2 - 3 settings).

1) Keep the "CH1" key pressed on the base card (ref. point 11, page 12), the signal LED will flash.

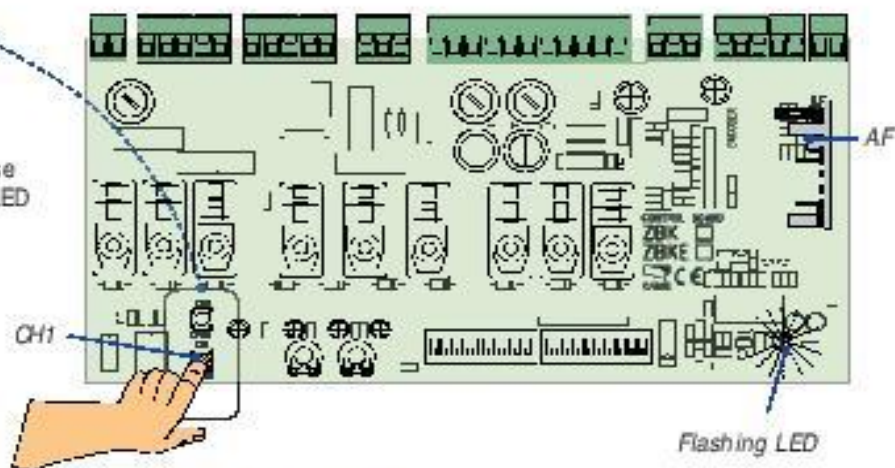

2) Press a transmitter key to send the code; the LED will remain lighted to signal memorization.

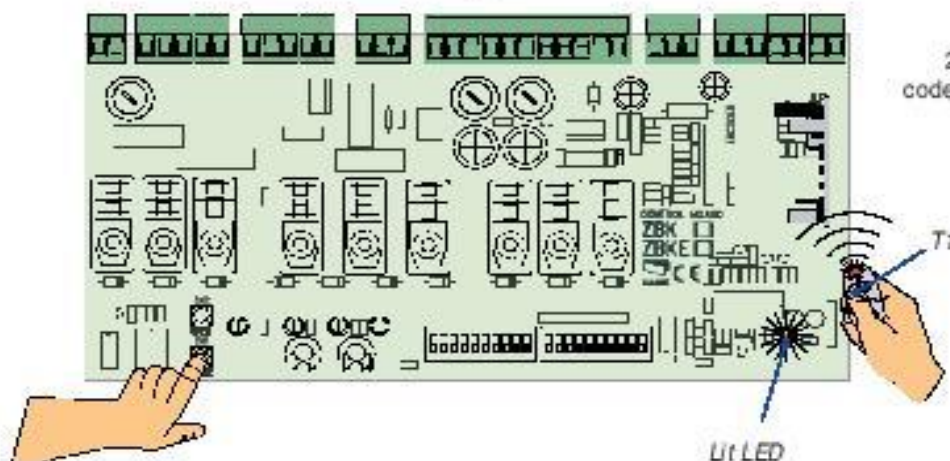

CH2 = Channel for direct commands to an auxiliary device or for the control of two paired motors, connected to B1-B2.

3) Repeat the procedure of parts 1 and 2 with the "CH2" key, associating it with another transmitter key.

N.B.: if the code needs to be changed, repeat the sequence described above.

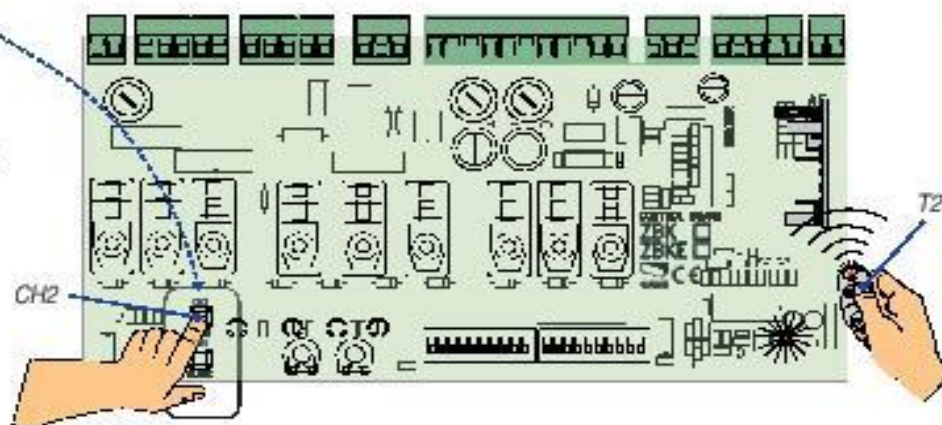

All the data and information contained herein is considered subject to change at any time and at our discretion

10 Maintenance

10.1 Periodic maintenance

 The unit does not require specific maintenance. Only as a precautionary measure and in case of intensive use, it is opportune to periodically (every six months) check that the electric cables are in good condition and that the bolts and nuts are tight, and oil the contact areas between the fixed and mobile sliding pieces.

All checks must be recorded (in a dedicated record-book).

10.2 Problem solving

THE GATE DOES NOT MOVE:

- check the 120V or 230V AC power on the terminals L-N;
- check the fuses;
- check the 24 V power on terminals 10-11;
- check the connection of the stop button; if not used, set the dip 10 to ON;
- check the safety device connection (partial stop); if unused, set dip switch 8 to ON
- check that the small access panel for blocking/release is closed.

THE GATE REMAINS IN THE OPEN POSITION:

- automatic closure disabled, see dip no.1;
- check all the command devices are working correctly;
- ensure that nothing is obstructing the safety devices;
- make sure all N.C. contacts are set to ON if not used.

11 Demolition and disposal

 In its premises, CAME CANCELLI AUTOMATICI S.p.A. implements an Environmental Management System certified in compliance with the UNI EN ISO 14001 standard to ensure environmental protection.

Please continue our efforts to protect the environment— which CAME considers one of the cardinal elements in the development of its operational and market strategies— simply by observing brief recommendations as regards disposal:

 **DISPOSAL OF PACKAGING** – The packaging components (cardboard, plastic, etc.) are all classifiable as solid urban waste products and may be disposed of easily, keeping in mind recycling possibilities.

Prior to disposal, it is always advisable to check specific regulations in force in the place of installation.

PLEASE DISPOSE OF PROPERLY!

 **PRODUCT DISPOSAL** – Our products are made up of various types of materials. Most of them (aluminium, plastics, iron, electrical wires, etc.) may be disposed of in normal garbage collection bins and can be recycled by disposing of in specific recyclable material collection bins and disposal in authorized centres. Other components (electrical boards, remote control batteries, etc.), however, may contain polluting substances. They should therefore be removed and given to qualified service companies for proper disposal.

Prior to disposal, it is always advisable to check specific regulations in force in the place of disposal.

PLEASE DISPOSE OF PROPERLY!

12 Manufacturer's warranty



MANUFACTURER'S DECLARATION

As per Enclosure 3 B of Machinery Directive 98/37/CE

Enclosed with the technical documentation (the original copy of the Declaration is available on request)

Date of the present declaration 07/12/2007

The representatives of

CAMECANCELLI Automatici S.p.A.
via Martiri della Libertà, 15
31030 Casson di Castel - Treviso - ITALY
(+39) 0422 4040 - fax (+39) 0422 4041
Internet: www.came.it - email: info@came.it

Hereby declare under their own responsibility that the products called ...

BK800 - BK1200/1210 - BK1800/1810 - BK2200/2210
BKE1200/1210 - BKE1800/1810 - BKE2200/2210

R001 - BSF - BRC5 - BRC10 - BRC15 - B4353
CGZ - CGZ5 - CGZ6 - CCT - CGIU

Also, they further declare and warrant that the products that are the subject of the present Declaration are manufactured in the respect of the following main harmonized provisions:

EN 592 serie 1 and 2	Machinery safety
EN 12453	Electrical safety, construction and other technical requirements
EN 12445	Electrical safety, construction and other technical requirements
EN 12578	System specific risk reduction measures (locking, etc.)
EN 60335 - 1	System or accessories risk reduction
EN 60204 - 1	Machinery safety
EN 61000 - 6 - 2	Electromagnetic Compatibility
EN 61000 - 4 - 4	Electromagnetic Compatibility
EN 61000 - 4 - 5	Electromagnetic Compatibility

IMPORTANT CAUTION

It is forbidden to market/use products that are the subject of this declaration before completing and incorporating them in total compliance with the provisions of Machinery Directive 98/37/CE.

Signature of the Representative

Machinery Directive 98/37/CE
Low Voltage Directive 73/23/EEC - 93/68/EEC
Electromagnetic Compatibility Directive 89/33/EEC - 92/31/EEC
R&TTE Directive 1999/5/CE

TECHNICAL MANAGER

Mr. Gianni Michalini

MANAGING DIRECTOR

Mr. Paolo Marzotto

CAME UNITED KINGDOM LTD
UNIT 3, ORCHARD BUSINESS PARK TOWN
STREET, SANDIACRE
NOTTINGHAM - NG10 5BP - U.K.
Tel 0044 115 9210430
Fax 0044 115 9210431

