

STArter STArter+

EN Original Installation and Operating Manual

Table of contents

General Information	3	Radio	19
Symbols	3	Functions	20
Safety instructions.....	3	DIP switches	20
Intended use	4	Obstacle detection (DIP 1, 2 + 3).....	20
Permitted gate wing dimensions	4	Automatic closing function	21
Technical data	4	Prewarning time (DIP 5).....	22
Dimensions	4	Fraba system (DIP 6).....	22
Preparations for assembly	6	Defined opening and closing (DIP 7)	22
Safety instructions.....	6	Partial opening (DIP 8).....	22
Tools required.....	6	Operation	23
Personal protective equipment	6	Safety instructions.....	23
Scope of supply.....	6	Opening the gate.....	23
Tips for installation	7	Closing the gate	23
General preparations	7	Pulse sequence of gate movement.....	23
Installation	8	Control unit reset.....	23
Safety instructions.....	8	Break-in protection due to automatic lock	23
Installation on ground.....	8	Emergency release	24
Foundation	8	Overload protection.....	24
Installing the console.....	9	Operation after a power failure.....	24
Console	9	Change the fuse.....	25
Installing operator on console	9	Maintenance and care	26
Installing the racks	9	Safety instructions.....	26
Connection	11	Regular testing	26
Earth.....	11	Disassembly.....	27
Mains connection	11	Disposal	27
Installation location.....	11	Troubleshooting	28
Set gate end position CLOSED.....	12	Tips on troubleshooting.....	28
Set gate end position OPEN	12	Troubleshooting	29
Connecting buttons or key switches.....	12	Connection diagram	30
What is button 2 for?.....	12		
Safety accessories	13		
Connecting photo cells.....	13		
Safety instructions.....	14		
Warning light	14		
24 V connection	14		
12 V connection	14		
Floating relay output.....	14		
Connecting external antenna	14		
TorMinal interface.....	14		
Special functions.....	14		
Additional accessories	14		
Commissioning	15		
General information.....	15		
Overview of the control system	15		
Safety instructions.....	15		
Programming the operator.....	15		
Resetting the control unit	16		
Adjusting the force tolerance.....	16		
Programming the handheld remote control.....	17		
Radio	18		
Safety instructions.....	18		
Display and button explanation	18		
External antenna	18		
Deleting the handheld transmitter from the radio receiver	18		
Deleting a channel from the radio receiver	19		
Deleting the radio receiver memory	19		
Teach-in by radio (HFL).....	19		

General Information

Symbols



ATTENTION SYMBOL:

Important safety instructions!
To ensure the safety of personnel it is important to follow all the instructions. Save these instructions!



IMPORTANT INFORMATION SYMBOL:

Information, useful advice!

1  Refers to a respective picture in the introduction or main text.

Safety instructions

General

- These installation and operating instructions must be read, understood and complied with by persons who install, use or perform maintenance on the operator.
- Keep this installation and operating manual accessible at all times.
- Installation, connection and initial commissioning of the operator may only be carried out by technically knowledgeable persons.
- Install the operator on correctly aligned gates only. An improperly aligned gate can cause serious injuries or damage the operator.
- The manufacturer assumes no liability for injuries, damage or breakdowns that occur due to non-compliance with the installation and operating instructions.
- Always ensure compliance with accident prevention regulations and current standards in each respective country.
- Take heed of and comply with the 'ASR A1.7 Technical Regulations for Workplaces' of the committee for workplaces (ASTA). (Applies to operators in Germany).
- Before any work on the operator disconnect it from the power supply and lock it to prevent reconnection.
- Only use OEM (Original Equipment Manufacturer) spare parts, accessories and mounting material.

Storage

- The operator must be stored in an enclosed, dry area at a room temperature of $-20 - +50$ °C.
- The operator should be stored horizontally.

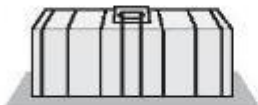
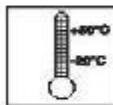

Operation

- The operator must be operated only if a non-hazardous force tolerance is set or safety is guaranteed by other safety equipment. The force tolerance must be set low enough to eliminate any danger of injury by the closing force (see 'Maintenance and care').
- **STArter:**
No active safety contact strip on the main closing edge necessary. Passive rubber profile edge sufficient.
- **STArter+:**
A active safety contact strip must be attached as a closing edge safety device.
- Never put your hand near a gate when it is moving or near moving parts.
- Do not drive through the gate until it is fully open.
- There is a risk of persons being crushed or cut by the mechanism or sharp edges of the gate.
- For automatic closing the main and auxiliary closing edges must be secured in accordance with the applicable directives and standards.
- Open and close the gate only if there are no children, persons, animals or objects within its area of movement.
- Regularly check the safety and protection functions and repair faults when they are detected. See Care and maintenance.

Radio remote control

- The remote control must only be used for devices and systems in which radio interference will not endanger people, animals or objects or the risk is reduced by other safety devices.
- The user must be informed that the remote control of equipment that presents a risk of accident may take place, if at all, only when there is direct visual contact with the equipment.
- The radio remote control may only be used if the door's movement can be watched and no persons or objects are within the range of movement.
- Store the handheld transmitter so that unintended operation, e.g., by children or animals, is impossible.
- The operator of the radio system is not protected from faults due to other telecommunications equipment or devices (e.g. radio-controlled systems that are licensed to operate in the same frequency range). If substantial interference occurs, please contact your appropriate telecommunications office which has radio interference measuring equipment (radiolocation).
- Do not operate the handheld transmitter in areas with sensitive radio communications or systems (e.g. airports, hospitals).

Type plate

- The type plate is attached to the inside of the base frame/housing. The type plate shows the exact type drawing and the date of manufacture (month/year) of the operator.

General Information

Intended use

- The operator is designed exclusively for opening and closing sliding gates (see EN 12433-1), referred to below as gates. Any other use does not constitute intended use. The manufacturer accepts no liability resulting from use other than intended use. The user bears the sole responsibility for any risk involved. It also voids the warranty.
- Gates automated with an operator must comply with all currently valid standards and directives: e.g. EN 12604, EN 12605.
- Maintain the safety clearances between the gate and surroundings as specified in EN 12604.
- The operator must be in good technical condition, and it must be used for its intended purpose with awareness of the hazards as described by the installation and operating manual.
- The gate must not have any rise or fall during opening or closing.
- Position the running rail to allow water to drain to prevent ice accumulation in winter.
- The gate must move freely in the guide and on the running rail to allow the operator to react sensitively and the gate to be switched off in emergency.
- The gate must have end stops in open and closed position, otherwise it may be pushed out of the guide in the event of an emergency release.
- Malfunctions which could affect safety must be corrected immediately.
- The gate must be stable and torsionally stiff, i.e. it must not bend or twist when being opened or closed.
- The operator cannot compensate for any defects in the gate or incorrect installation of the gate.
- Do not install the operator in potentially explosive areas.
- Do not operate the operator in rooms with corrosive atmospheres.

For the Declaration of Conformity for the radio see:

www.sommer.eu/mrl

Permitted gate wing dimensions

Data	STARter	STARter*
Min. travel path	Min. 1,400 mm	Min. 1,400 mm
Max. travel path	Max. 6,000 mm	Max. 8,000 mm
Weight	Max. 300 kg	Max. 400 kg
Gate inclination	0 %	0 %

Technical data

Data	STARter	STARter*
Rated voltage	220 ... 240 AC/V	220 ... 240 AC/V
Rated frequency	50/60 Hz	50/60 Hz
Operating temperature range	\downarrow -20 to \uparrow +50 °C	\downarrow -20 to \uparrow +50 °C
Protection code	IP54	IP54
Max. torque	11 Nm	11 Nm
Rated torque	3.3 Nm	3.3 Nm
Rated current consumption	0.6 A	0.6 A
Rated wattage	140 W	140 W
Max. speed	170 mm/s	240 mm/s
Power consumption, standby	2 W	2 W
Weight	8 kg	8 kg
Operating time	S3 30 %	S3 30 %

Workplace-related emission value < 75 dBA – operator only

Dimensions

All dimensions are in millimetres. The operator is locked

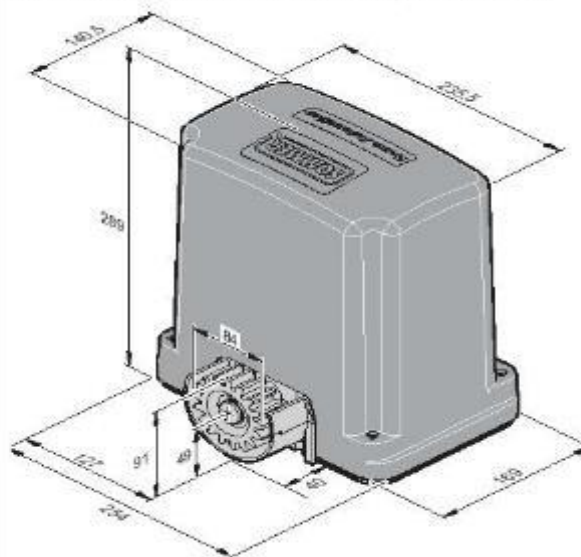

General Information

Declaration of Installation

for the installation of an incomplete machine in accordance
with the Machinery Directive 2006/42/EC, Appendix II, Section 1 B

SOMMER Antriebs- und Funktechnik GmbH

Hans-Böckler-Straße 21 - 27

73230 Kirchheim/Teck

Germany

hereby declares that the operator

STArter/STArter⁺

was designed, developed and manufactured in compliance with

- Machinery Directive 2006/42/EC
- Low Voltage Directive 2014/35/EU
- Directive on Electromagnetic Compatibility 2014/30/EU
- RoHS Directive 2011/65/EU.

The following norms were used:

- | | |
|---------------------------------|--|
| • EN ISO 13849-1, PL "C" Cat. 2 | Safety of machines – Safety-related parts of controls
– Part 1: General design guidelines |
| • EN 60335-1, where applicable | Safety of electrical appliances/operators for gates |
| • EN 61000-6-3 | Electromagnetic compatibility (EMC) – interference |
| • EN 61000-6-2 | Electromagnetic compatibility (EMC) – interference resistance |
| • EN 60335-2-103 | General safety requirements for household and similar electrical appliances
– Part 2: Special requirements for operators for gates, doors and windows |

The following requirements of Annex 1 of the Machinery Directive 2006/42/EC are met:

1.1.2, 1.1.3, 1.1.5, 1.2.1, 1.2.2, 1.2.3, 1.2.4, 1.2.6, 1.3.2, 1.3.4, 1.3.7, 1.5.1, 1.5.4, 1.5.6, 1.5.14, 1.6.1, 1.6.2, 1.6.3, 1.7.1, 1.7.3, 1.7.4

The special technical documentation was prepared in accordance with Annex VII Part B and will be submitted to regulators electronically on request.

The incomplete machine is intended for installation in a gate system only to form a complete machine as defined by the Machinery Directive 2006/42/EC. The gate system may only be put into operation after it has been established that the complete system complies with the regulations of the above EC Directive.

The undersigned is responsible for compilation of the technical documents.

Kirchheim, 20.04.2016



i.V. 

Jochen Lude
Responsible for documents

Preparations for assembly

Safety instructions



ATTENTION!

Follow all installation directions. Improper installation may cause serious injuries.

- The voltage of the power source must correspond with the voltage listed on the operator type plate.
- The contacts of all devices to be connected externally must be safely isolated from the mains voltage supply according to IEC 60364-4-41.
- Comply with the standard IEC 60364-4-41 when laying the leads of the external devices.
- The operator may be installed, connected and commissioned by competent personnel only.
- Do not move the gate, if there are any people, animals or objects in the area of movement.
- Keep children, disabled persons and animals away from the gate.
- Wear safety glasses when drilling the fastening holes.
- Cover the operator during drilling to prevent dirt from entering the operator unit.



ATTENTION!

The foundation must be solid and stable. Only install the operator on a correctly aligned gate. An incorrectly aligned gate could cause serious injury.

- Gates must be stable in themselves, since high traction and compression forces are encountered. Reinforce lighter gates made of plastic or aluminium if necessary before installation. Ask a specialist retailer for advice.
- Remove or disable gate locks.
- Use only approved fasteners (e.g. anchor fittings, bolts). The fasteners must match the material of the ground.
- Check the gate for smooth operation.

Tools required

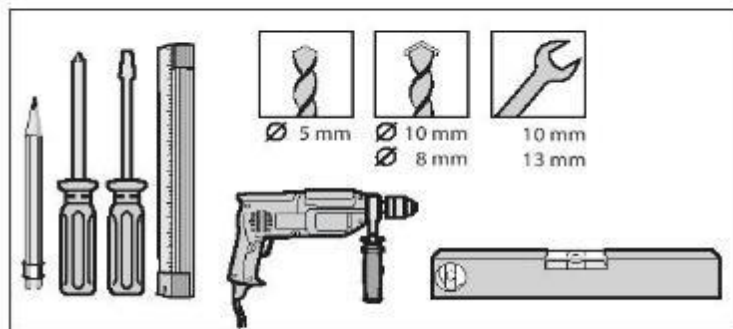

Personal protective equipment

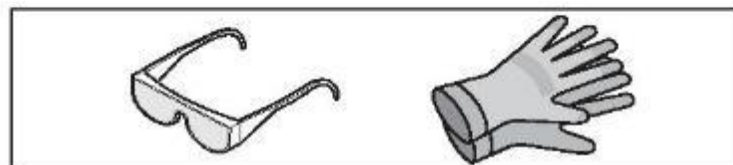

- Safety glasses (for drilling).
- Work gloves.

Scope of supply

- Check the package before installation to avoid unnecessary work and expense if a part is missing.
- The actual scope of supply may vary depending on the operator version.

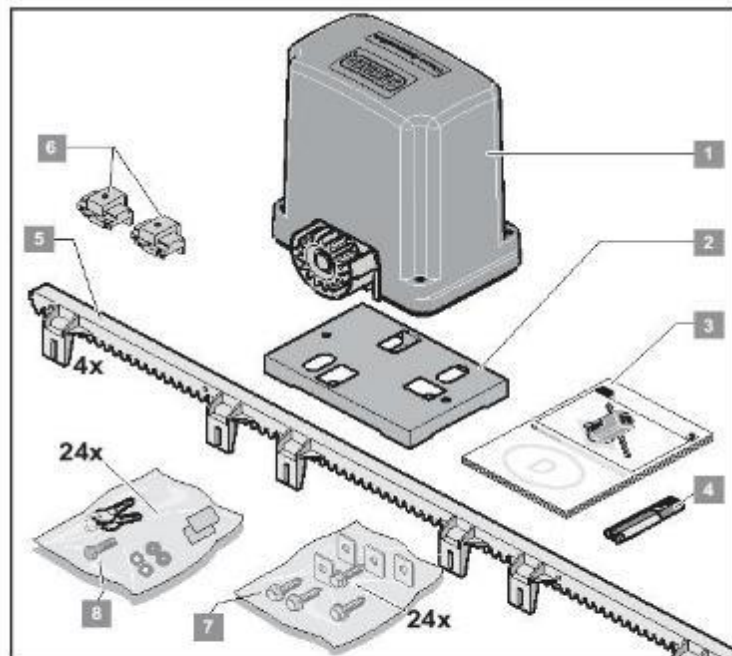

Complete set

Package (l x w x h)	1035 x 350 x 270 mm	
Weight	12 kg	
1.	1 pc.	Sliding gate operator with controller and radio receiver
2.	1 pc.	Console
3.	1 pc.	Installation and Operating Manual
4.	1 pc.	4-command handheld transmitter
5.	4 pcs.	1 m rack
6.	2 pcs.	Limit switch
7.	1 pc.	Auxiliary mounting plate x 4 pcs. Spring washer x 2 pcs. Screw x 2 pcs. U-washer x 2 pcs. Lock washer x 2 pcs. Key x 2 pcs.
8.	1 pc.	Installation bag (fasteners) Screw x 24 pcs. 24 pcs. Washer

Single operator

Package (l x w x h)	400 x 355 x 225 mm	
Weight	8 kg	
1.	1 pc.	Sliding gate operator with controller and radio receiver
2.	1 pc.	Console
3.	1 pc.	Installation and Operating Manual
4.	2 pcs.	Key for cover
8.	2 pcs.	Solenoid limit switch

Preparations for assembly

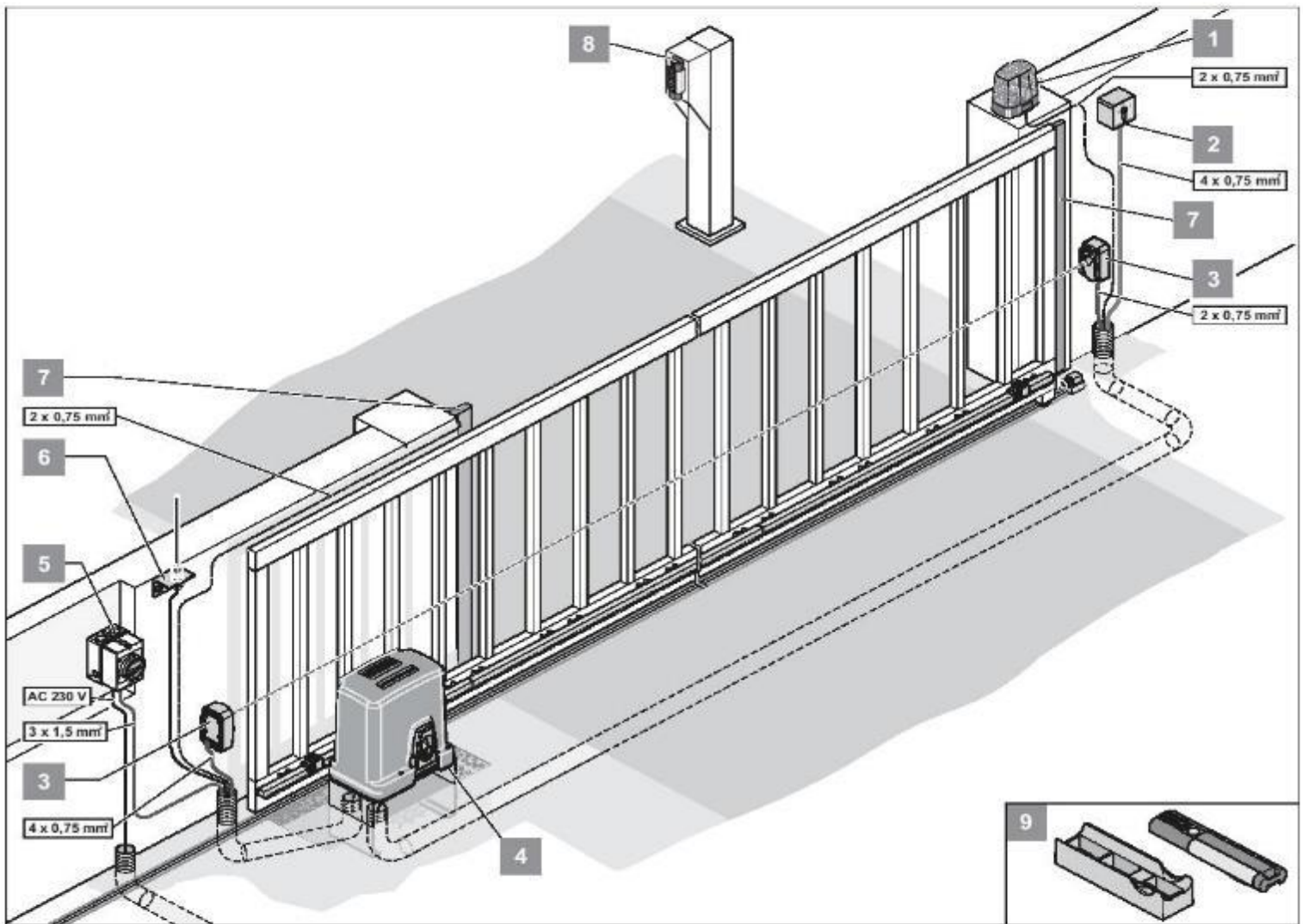

Tips for installation

- A safety device must always be connected as an NC contact. This ensures that safety is always guaranteed in the event of tripping or a fault.
- Determine the position of the accessories before installation together with the operator.



IMPORTANT INFORMATION!

Additional pulse transmitters are: handheld transmitters, Telecody, wireless indoor switches and key switches. In the case of the handheld transmitter, Telecody, or wireless indoor switches a connecting line to the operator is not required (contact your dealer).

1.	Warning light DC 24 V
2.	Key switch (1 or 2 contact)
3.	Photo cell (prescribed for automatic closing, see EN 12543)
4.	Console
5.	Main switch (lockable)
6.	Rod antenna (including 10 m cable)
7.	Safety contact strip (8.2 kohm, Fraba system)
8.	Telecody
9.	Car/wall holder for handheld transmitter

General preparations

- Remove or disable all locking devices (electric lock, bars, etc.) before installing the operator.
- The gate must have a stable structure and must be suitable.
- The gate must not show excessive lateral deviation throughout its range of movement.
- The system wheels and bottom track and the roller and top guide must operate without excessive friction.
- End stops must be installed at the "gate OPEN + gate CLOSED" positions to prevent derailing of the gate.
- Install empty ducts under the gate for the cables of the mains supply line and the accessories (light barrier, warning light, key switch, etc.).

Installation

Safety instructions

- The control unit must be connected to the power supply by an electrician only.
- Ensure that the operator is securely fastened to the ground and the racks on the gate to withstand the high forces generated when opening and closing the gate.
- If a button is used for opening or closing, it must be installed at a height of at least 1.6 m to prevent operation by children.
- The rack must not press on the pinion during operation, otherwise the operator will be damaged.
- Follow the standards for installation, e.g.: EN 12604, EN 12605.

Installation on ground



IMPORTANT INFORMATION!

Dispose of packaging according to local regulations.

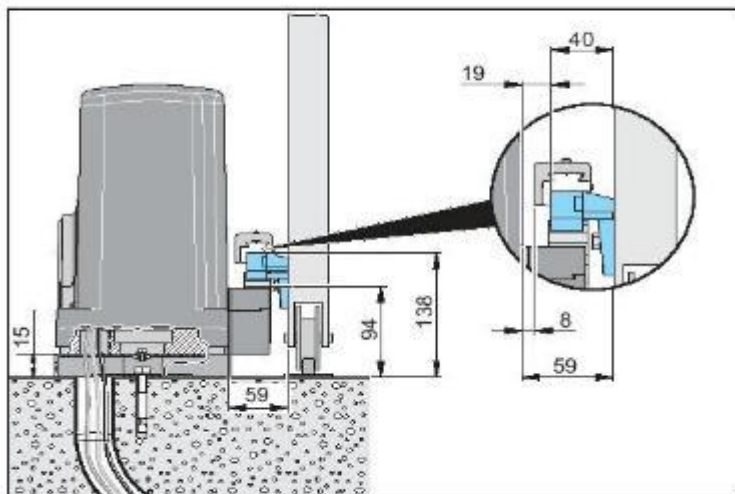

Foundation

- For free-standing gates install the operator centrally between the roller blocks.
- The foundation must extend below the frost line (approx. 800 mm in Germany).
- The foundation must be cured and horizontal.
- Foundation dimensions as shown.

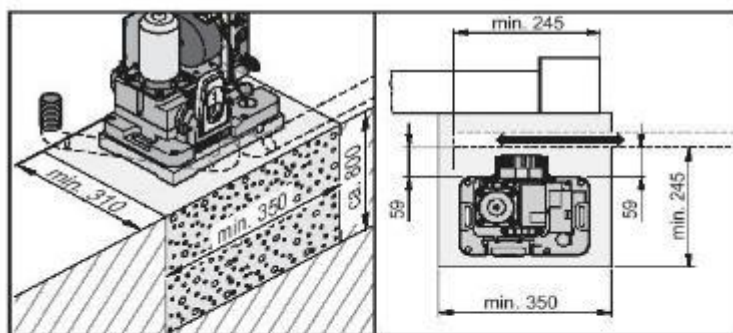
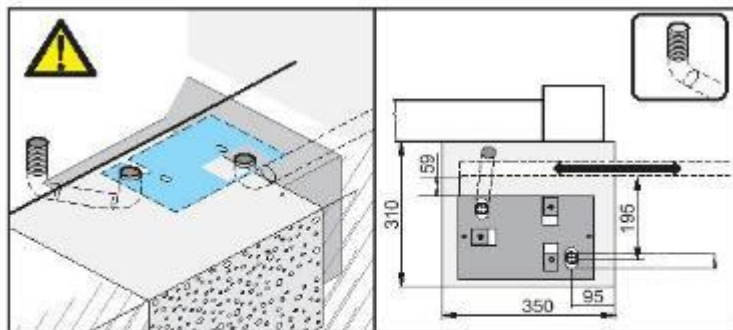

Installation

Installing the console

1. Check the scope of supply.
2. Measure and mark drill holes in foundation.
3. Make drill holes.
4. Insert anchor fittings.
5. Screw down console.

Console



IMPORTANT INFORMATION!

Always note the dimensions and angles, see "Installation location".

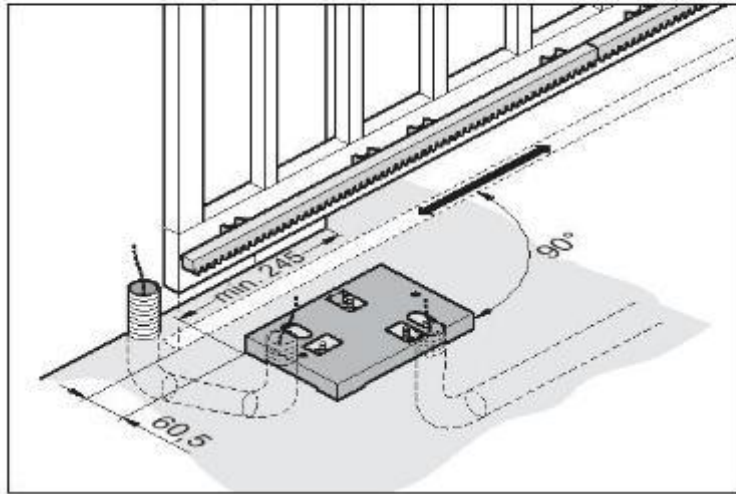

6. Note the dimensions of the console and cable ducts for the mains connection and accessories (e.g. photo cell) during excavation, see "Foundation".
7. Check the dimensions and the horizontal position of the console. Screw down or concrete in cable ducts and console.

Installing operator on console

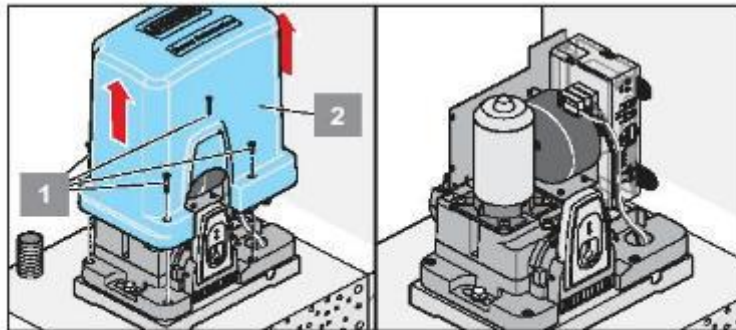

8. Unscrew the four screws (1) and remove cover (2).
9. Remove controller (3).
10. Screw operator to console. Use the mounting plates (30 x 20 x 1.5 mm) to set a distance of 1.5 mm in between operator and console. This allows optimum adjustment of the gear play.

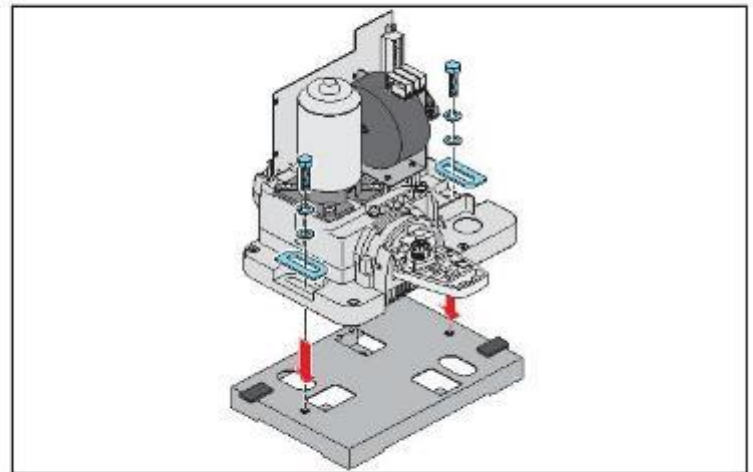

Releasing the operator

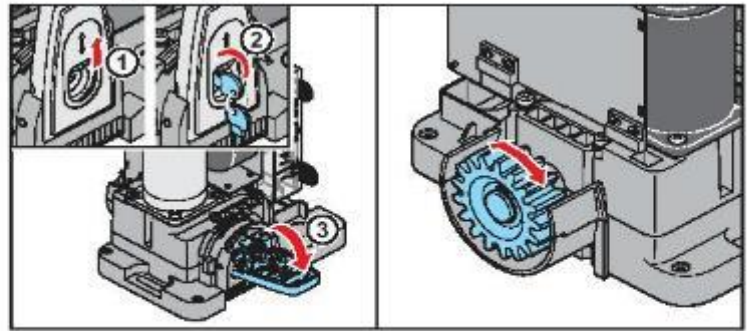

11. Lift protective cover (1).
12. Insert key and turn.
13. Lift cover to the outside.
14. Operator is released and the gate can be moved manually.

Installing the racks



ATTENTION!

Steel racks must have a minimum width of 12 mm. Narrower steel racks may damage the drive



IMPORTANT INFORMATION!

The complete kit contains four racks each 1 m long. Contact your dealer if you require more racks.

- The toothed rack must not exert any pressure on the pinion in any position of the gate, otherwise the gearing will get damaged.
- Always start installing the rack on the passage side of the gate.
- The holes must always be marked near the pinion.

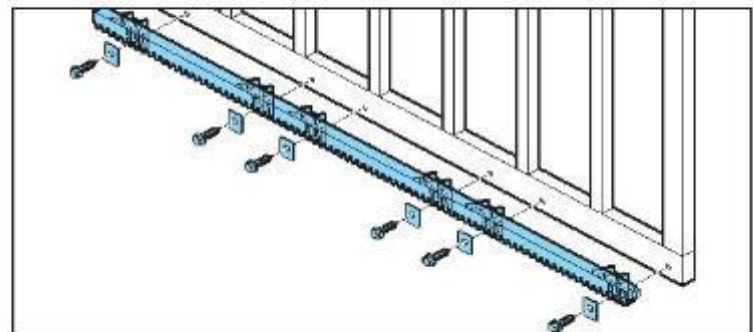

Installation

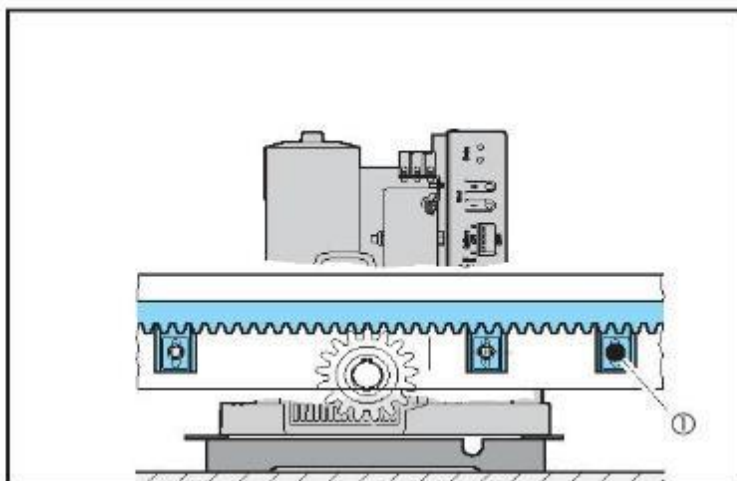
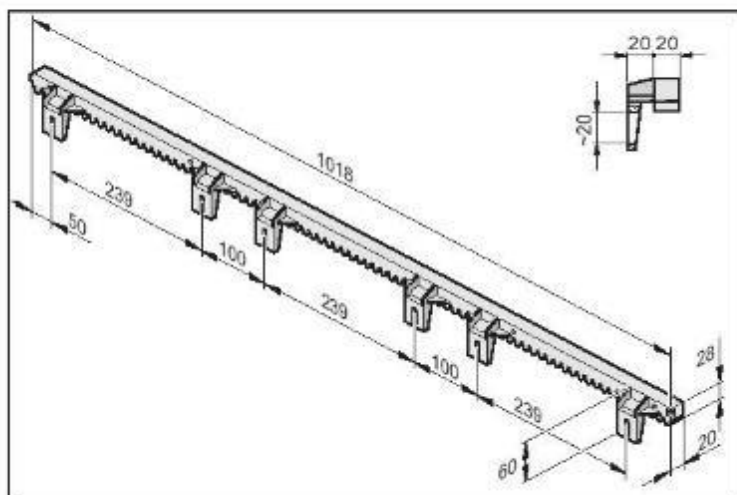

1. Before marking the first hole open the gate completely by hand.
2. Position the rack on the pinion and align it horizontally with a spirit level.
3. Mark the first hole, drill it and fasten.

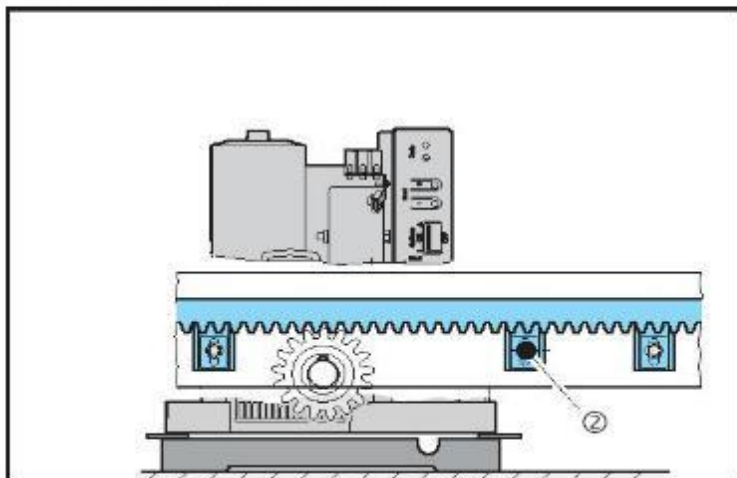

4. Push the gate in 'closed' direction until the next drilling point is positioned in accordance with the illustration and mark the holes again.
5. Repeat until all drill positions are marked.
6. Fasten rack.

Installing additional racks



TIP!

First mark the two outer holes and drill. Fasten temporarily and mark the remaining holes. Then remove the rack and drill the remaining holes. Then the rack can be finally bolted in position.

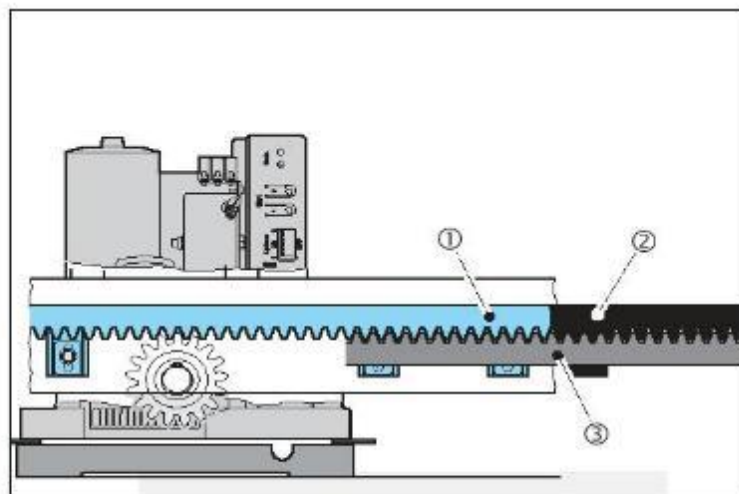

1. Position second rack (2) flush with the first rack (1) and hold another rack (3) against them from below so the teeth of the additional rack (3) mesh with the teeth of the two top racks (1 and 2). This will ensure that the second rack (2) is accurately fitted.
2. Mark and drill the holes for the second rack.
3. Attach rack.
4. If a third rack is required, use the same procedure as for the second rack.

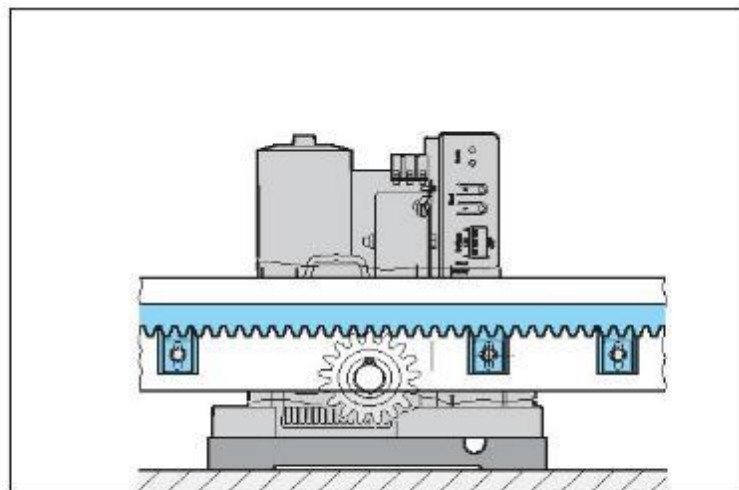

5. Remove the auxiliary mounting plates.

Connection

GND

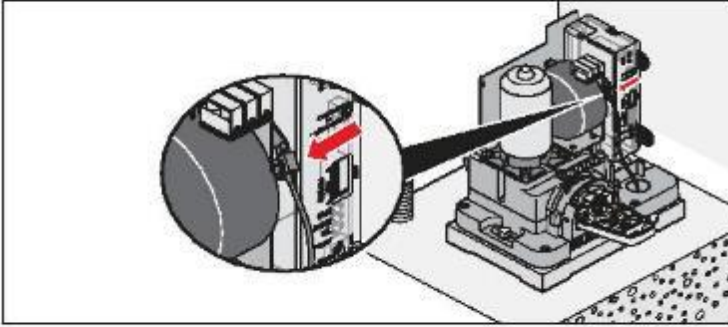

1. Connect the earth wire (factory-installed) to the earth clamp (see diagram).

Mains connection

- Permissible cable cross-sections: 2.5 mm² max.

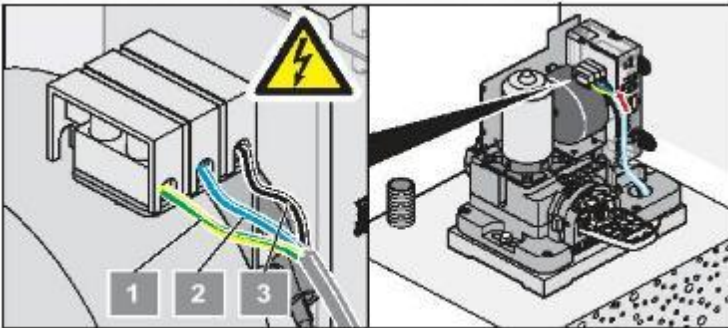

1.	PE	Protective earthing conductor
2.	N	Neutral wire
3.	L	Mains supply line AC 220 V–240 V

Installation location



IMPORTANT INFORMATION!

As delivered the operator is installed on the left and the gate opens to the left.

Operator left, calculating gate wing length

L = required gate wing length

A = available passage width

X = overlap (e.g.: gate wing – post)

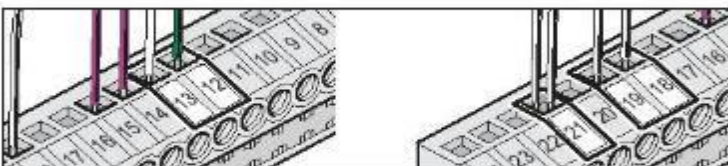

Terminal	Cable colour	Name
12	Green	Motor
13	White	Motor
18	White	Gate OPEN sensor
19	White	Gate CLOSED sensor
21	White	Gate OPEN + CLOSED sensor ground

Operator right, calculation of gate length

L = required gate wing length

A = available passage width

X = overlap (e.g.: gate wing – post)

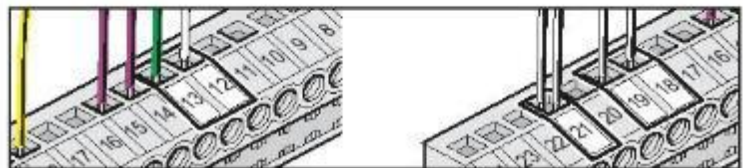
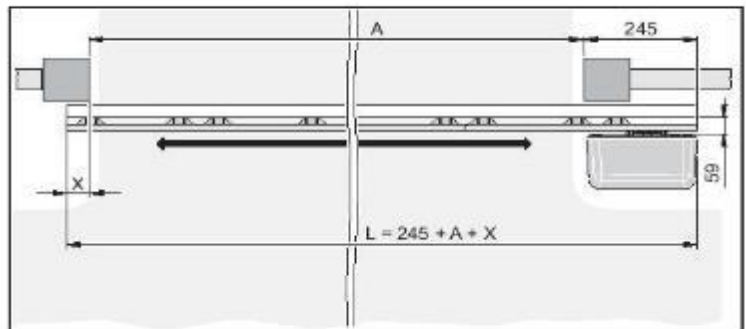

Terminal	Cable colour	Connection
12	White	Motor
13	Green	Motor
18	White	Gate OPEN sensor
19	White	Gate CLOSED sensor
21	White	Gate OPEN + CLOSED sensor ground



IMPORTANT INFORMATION!

For right-hand installation reverse motor connection 12 + 13 and sensor lines 18 + 19.



IMPORTANT INFORMATION!

For terminal diagram overview, see overleaf.



IMPORTANT INFORMATION!

For max. line lengths see terminal plan overleaf.

Connection

Set gate end position CLOSED

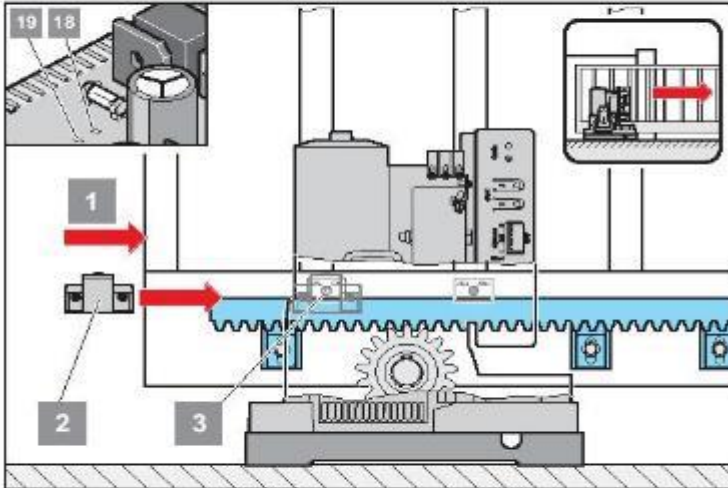

- Push the gate into gate end position CLOSED (1).
- Slide the limit switch magnet (2) to sensor (3) until the latter switches (LED on the control unit lights up).

Operator left: LED 18 -> gate CLOSED
Operator right: LED 19 -> gate CLOSED

- Tighten limit switch magnet 2.

Set gate end position OPEN

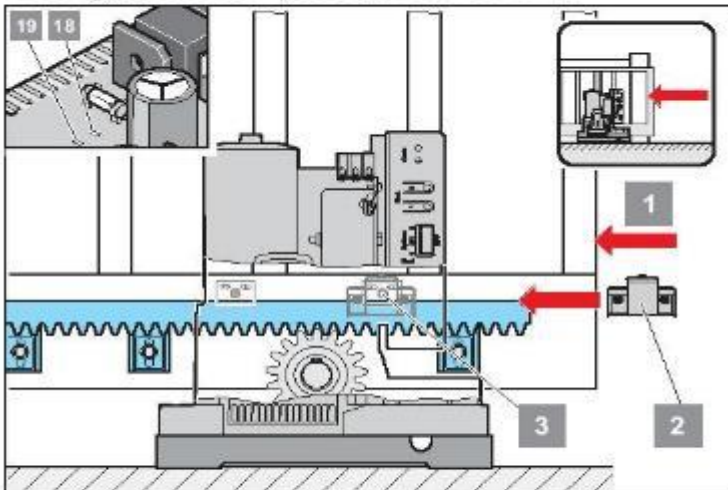

- Push the gate into gate end position CLOSED (1).
- Slide the limit switch magnet (2) to sensor (3) until the latter switches (LED on the control unit lights up).

Operator left: LED 19 -> gate OPEN
Operator right: LED 18 -> gate OPEN

- Tighten limit switch magnet 2

Note: Fine adjustment



Connecting buttons or key switches



ATTENTION!

When actuating the key switch the operator must keep clear of the movement zone of gate and must have a direct view of it.



IMPORTANT INFORMATION!

The button inputs are potential-free!

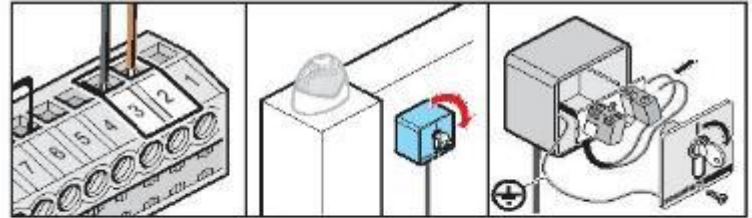

Button 1:

Terminals 2 + 3

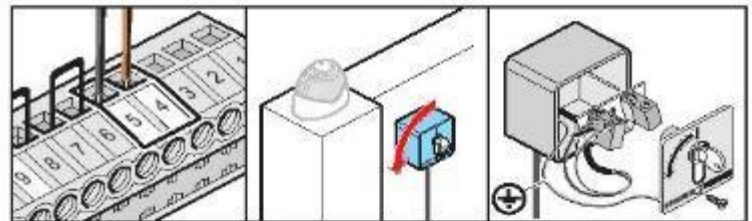

Button 2:

Terminals 4 + 5

What is button 2 for?

For settings see chapter "Functions and connections"

Defined opening and closing (2-channel mode)

Button 1 opens and button 2 closes the gate.

Partial opening

Button 1 always opens and closes the gate completely.

Button 2 only opens the gate partially and closes the gate.

Dead man's function (switch on with TorMinal only)

Button 1 opens the gate while the button is pressed.

Button 2 closes the gate while the button is pressed.

Safety accessories

Safety instructions



ATTENTION!

Before working on the gate or the operator always disconnect the control unit from the power supply and lock to prevent reactivation.

Connecting photo cells

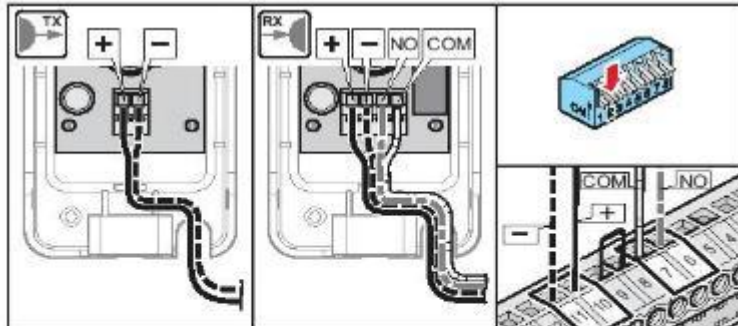

Safety input terminal 1 (Safety-1)

Terminals 6 + 7: Tested connection for floating contacts, only if DIP switch 2 OFF.

Voltage supply

Terminal 10: Regulated DC 24 V, max. 0.1 A
Terminal 11: Earth

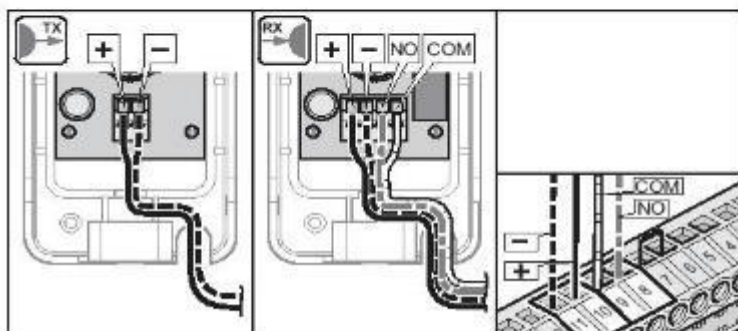

Safety input terminal 2 (Safety-2)

Terminals 8 + 9: Tested connection for floating contacts, reacts only with gate CLOSED

Voltage supply

Terminal 10: Regulated DC 24 V, max. 0.1 A
Terminal 11: Earth

STARter+:

Connect active safety contact strip (optional with STARter)



IMPORTANT INFORMATION!

For the STARter+ (optional for STARter) either an 8.2 kohm safety contact strip or an optoelectronic system can be connected, but not both at the same time.

Electrical safety contact strip (8.2 kohm)

Analysis 8.2 kohm. Connection without special analytical device, the controller does the evaluation.

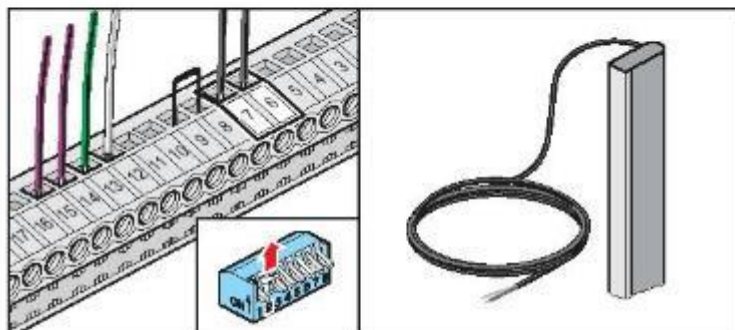

Terminal 6 + 7: Tested connection for an 8.2 kohm strip
DIP switch 2: ON

Optoelectronic safety contact strip

One strip can be connected without special analytical device, the controller does the evaluation. Connection of two strips with special analytical device only.

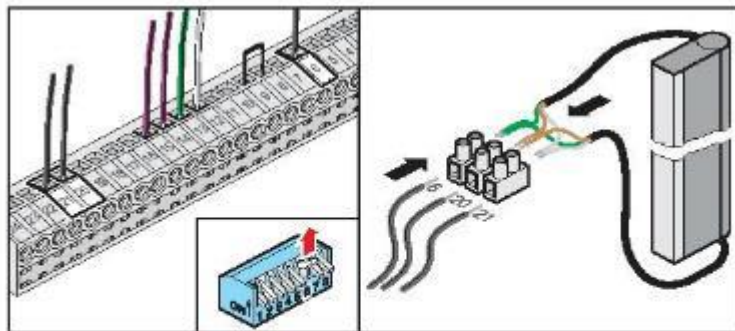

Terminal 6: Green cable from Fraba System
Terminal 20: Brown cable from Fraba system
Terminal 21: White cable from Fraba system
DIP switch 6: ON
DIP switch 2: OFF

Additional accessories

Safety instructions



ATTENTION!

Before working on the gate or the operator always disconnect the control unit from the power supply and lock to prevent reactivation.

Warning light

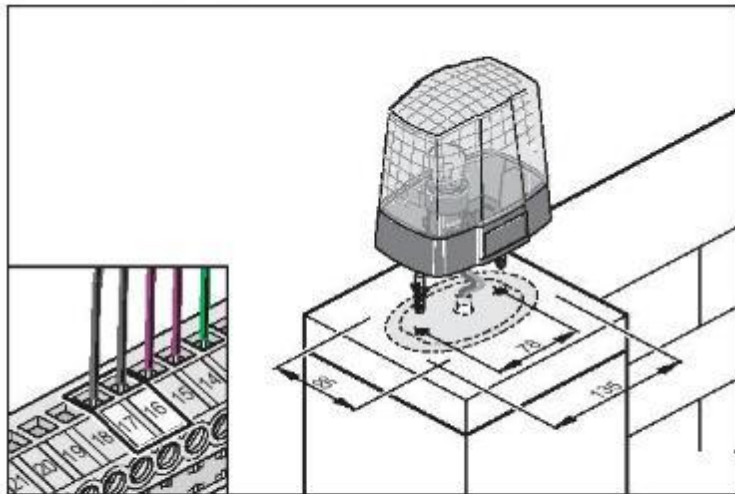

Terminal 16
Terminal 17

24 V connection

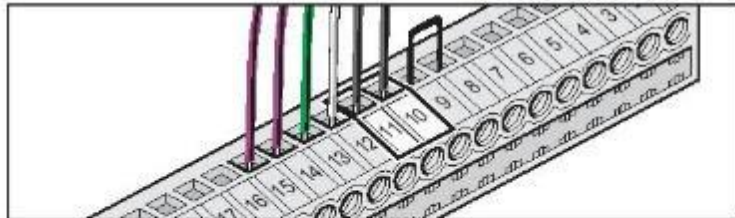

Terminal 10: Regulated DC 24 V, max. 0.1 A
Terminal 11: Earth

12 V connection

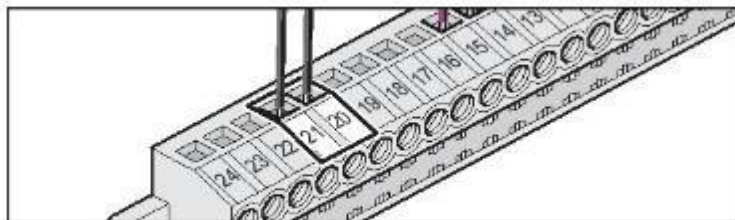

Terminal 20: DC 12 V, max. 0.1 A
Terminal 21: Earth

Floating relay output

Every time the operator is started, a pulse is pending at the relay output that can be used to switch on lights in a stairwell, for example.

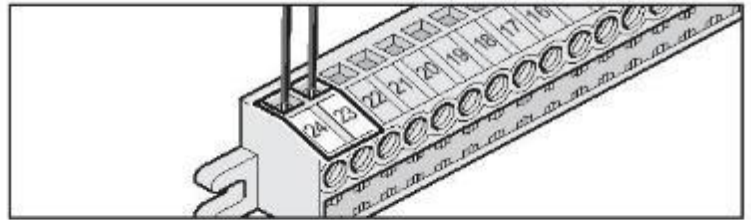

Terminals 23 + 24 Max. switching capacity: AC 230 V, max. 5 A
The "max. switching duration" can only be changed with the TorMinal.

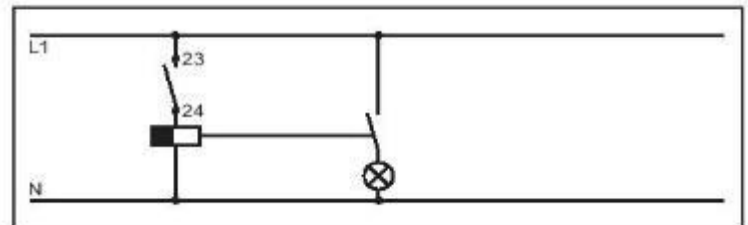

Example: automatic lights in stairwell

Connecting external antenna

See p. 18 Chapter "External antenna"

TorMinal interface

See TorMinal operating manual.

Special functions

Dead man operation

Service monitor

This and additional functions or settings require the TorMinal.

Commissioning

General information

- DIP switches set to "OFF" position on delivery.
- Do not apply external voltage to the connections of the control system, otherwise the control system is immediately destroyed.

Overview of the control system

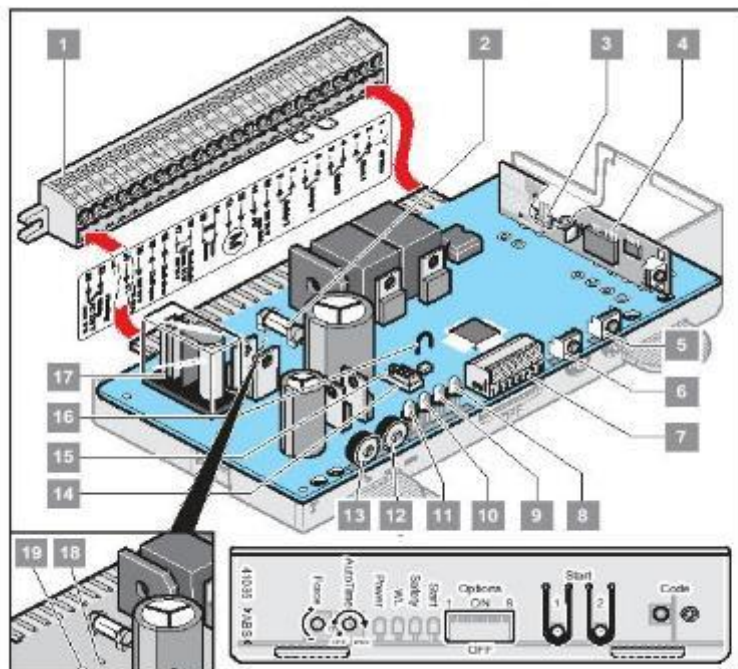

1.	Direct connector, 24-pole
2.	Fuse for warning light-1 connection, terminal 16 + 17
3.	Connection of the external antenna
4.	Radio receiver
5.	Button 2 (T2 *)
6.	Button 1 (T1 *)
7.	DIP switch 1-8
8.	Start (LED 4 *) Lights when a radio command is sent or a button is pressed.
9.	Safety (LED 3 *) Lights when a safety input is actuated.
10.	WL (LED 2 *) Flashes when the operator opens or closes the gate.
11.	Power (LED 1 *) Lights when mains power is on.
12.	Potentiometer (P2 *) for setting time of automatic closing
13.	Potentiometer (P1 *) for adjusting the power tolerance.
14.	Connection of TorMinal
15.	Protection against incorrect insertion for the connection of TorMinal
16.	Wire jumper, disconnecting switches off soft running.
17.	Relay contact, Terminals 23 + 24
18.	LED: Operator left: end position gate CLOSED Operator right: Door end position OPEN
19.	LED: Operator left: Door end position OPEN Operator right: Door end position CLOSED

* See the controller pcb for this label.

Safety instructions



IMPORTANT INFORMATION!

After installation of the operator the person responsible for installation of the drive must issue an EC Declaration of Conformity for the gate system in accordance with Machinery Directive 2006/42/EC and attach the CE symbol and a type plate. This is also required for private installations and also if the operator is retrofitted to a manually operated gate. This documentation and the Installation and Operating Instructions are retained by the operator.



ATTENTION!

The adjustment of the force tolerance is safety-relevant and must be performed by qualified personnel with the utmost care. If the adjustment of the spring unit is excessively high, people or animals could be injured and objects damaged. Select a force tolerance that is as low as possible so that obstacles are detected quickly and safely.

Programming the operator

The control unit has an automatic force setting. The control system memorizes the required force during the "OPEN" and "CLOSE" gate movements and stores it when the end position has been reached.

Locking the operator

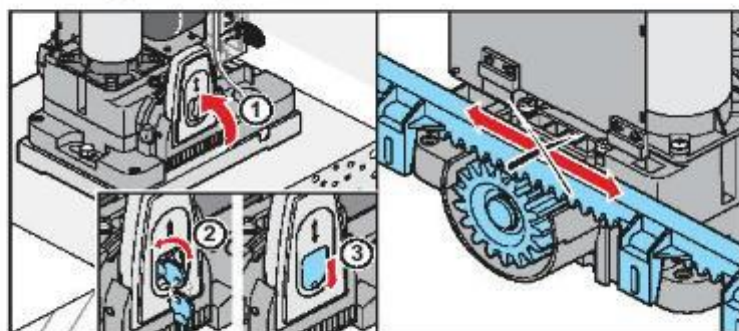

1. Traverse operator to centre position.
2. Lift lever (1) up and lock with key until the motor locks – loud click. Release lever (1).
3. Remove key and push dust cap down.



IMPORTANT INFORMATION!

Move gate back and forth by hand so the pinion meshes with the rack more easily and the motor can lock.

- ⇒ Operator is locked and the gate can only be moved with the motor
4. Plug in controller.
 5. Switch on main switch.
⇒ LED (power) on

Commissioning

Resetting the control unit

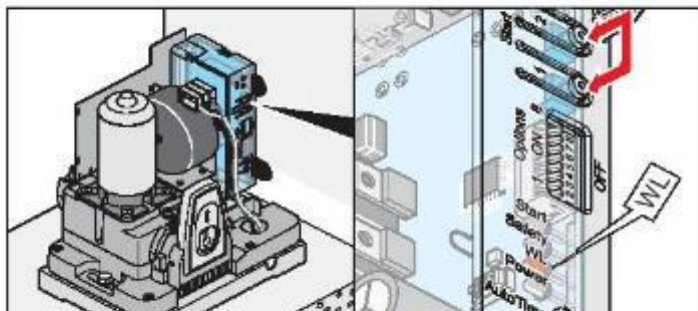

1. Press the buttons (1 + 2) until the "WL" LED extinguishes.
⇒ "WL" LED off – force values deleted.
2. Press the buttons (1+2).
3. Reset is complete.
⇒ "WL" LED flashes

Learn the force values:

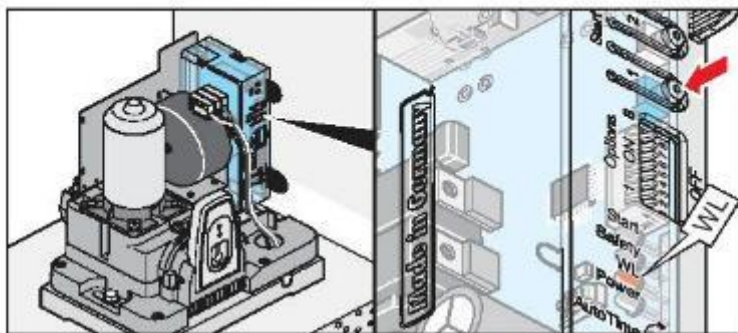

1. Press button (1).
⇒ Gate opens to end switch magnet (end position gate OPEN)
⇒ If the gate does not open, the motor may be incorrectly connected (see "Connection" page 11)
⇒ "WL" LED flashes.
2. Press button (1).
⇒ Gate closes to end switch magnet (end position gate CLOSED)
⇒ "WL" LED flashes.
3. Repeat Steps 1 and 2.
⇒ The "WL" LED switches on and off - force values have been learned.
4. Test gate OPEN and CLOSED end positions by opening and closing the gate. Adjust end positions if necessary until the gate opens and closes completely



IMPORTANT INFORMATION!

Soft running length with gate CLOSED min. 500 mm.

Adjusting the force tolerance

- Shut-off force = learned force + force tolerance (adjustable with the "Force" potentiometer)
- If the force is not sufficient for opening or closing the gate completely, increase the force tolerance by rotating the potentiometer clockwise.
- If the setting is changed while the gate is opening or closing, the control unit imports the setting next time the gate is opened.
- After setting the force tolerance it may be necessary to reset the end positions.

Checking the force tolerance



ATTENTION!

Rubber safety strips must be used on the main and auxiliary closing edges. No sliding gate without safety strips may be used!

- ⇒ Our program contains various safety strips, both active (triggers an immediate reversal of the gate at contact) and passive (takes up part of the inertial mass of the moving gate and causes a reversal of the operator by the force cut-off). This strip can be ordered from a SOMMER authorized dealer.

See care and maintenance/regular testing.

Setting the force tolerance to the automatically learned force. The potentiometer setting is imported again at every start.

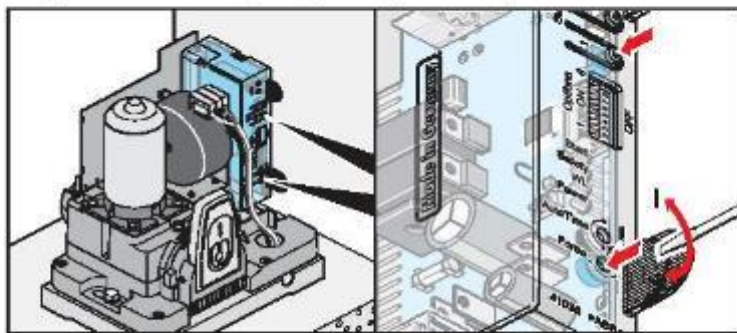

- Left stop of potentiometer (-) is the lowest force tolerance, right stop (+) is the highest tolerance.

Test run:

1. Close the gate.
2. Press button (1) once.
Gate opens to gate OPEN limit position.
3. Press button (1) once.
The door closes up to the limit position door CLOSED.
4. If one of the set gate end positions is not reached (gate OPEN or CLOSED), the force tolerance must be increased.
5. Turn "Force" potentiometer approx. 10 degrees clockwise.
6. Repeat test run until the gate reaches the gate OPEN and CLOSED end positions.

Commissioning

Programming the handheld remote control



IMPORTANT INFORMATION!

Before programming the handheld transmitter for the first time, always clear the radio receiver memory completely.

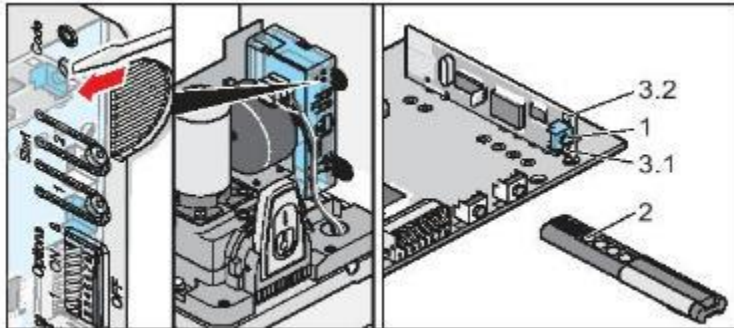

Deleting the radio receiver memory

1. Press and hold the teach-in button (1).
 - ⇒ After 5 seconds the LED (3.1 or 3.2) flashes – after another 10 seconds the LED (3.1 or 3.2) is steady.
 - ⇒ After a total of 25 seconds all LEDs are on (3.1 and 3.2).
2. Release the teach-in button (1).

Programming the handheld remote control

1. Press the learn button (1).
 - 1 x for channel 1; the LED (3.1) lights up.
 - 2 x for channel 2; the LED (3.2) lights up.
 - ⇒ If no code is sent within 10 seconds, the radio receiver switches to Normal mode.
2. Press the desired handheld transmitter button (2) until the LED (3.1/3.2) extinguishes, depending upon which channel has been selected.
 - ⇒ LED goes out – programming is finished.
 - ⇒ The handheld transmitter has transferred the radio code to the radio transmitter.
3. Repeat the above steps to program by teach-in any additional handheld transmitters. A maximum of 112 storage locations for each radio receiver are available.



IMPORTANT INFORMATION!

Press the learn button (1) until all LEDs are off to cancel the learn mode.

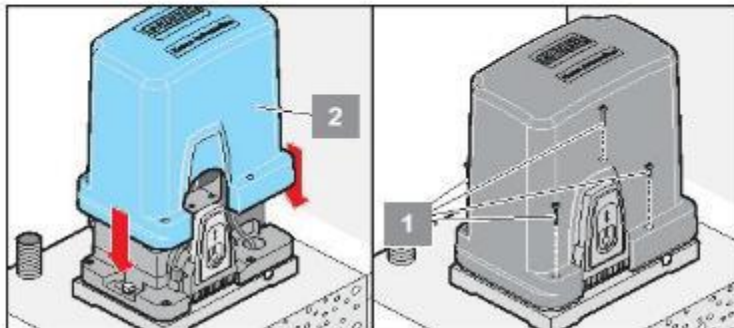

1. Position cover (2) and push down.
2. Fasten cover.
 - ⇒ Commissioning complete.

Radio

Safety instructions

- The local safety regulations for the system must be complied with to ensure safe operation. Information is available from electrical utility companies, VDE (Association for Electrical, Electronic & Information Technologies) and professional associations.
- The operator is not protected against interference caused by other telecommunications equipment or devices (e.g., wireless systems which are being operated properly in the same frequency range).
- Replace the handheld transmitter unit's batteries if you experience reception problems.

Display and button explanation

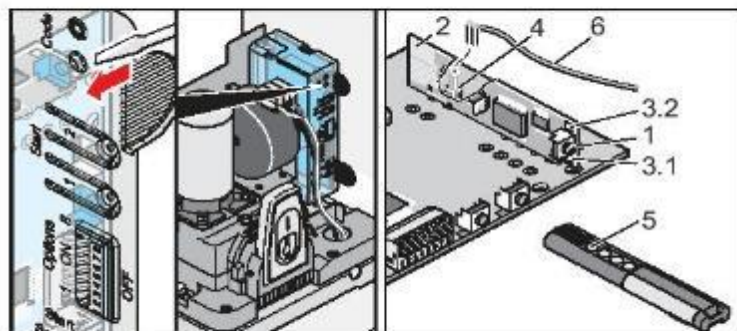

- | | |
|----|---|
| 1. | Sets the radio receiver to different operating modes:
Learn, delete, normal mode |
| 2. | internal antenna |



IMPORTANT INFORMATION!

Channel 2 (3.2) is only required for the "Defined opening and closing or partial opening" functions.

- | | |
|----|--|
| 3. | LEDs – show which channel has been selected.
3.1 LED radio channel 1
3.2 LED radio channel 2 |
| 4. | Connection for external antenna
An external antenna can be used if the range with the internal antenna is not sufficient. See p. 18 Chapter "External antenna." |
| 5. | Handheld transmitter button |
| 6. | External antenna |

External antenna

- If reception is inadequate with the radio receiver internal antenna, an external antenna can be connected.
- The antenna cable may not exert any mechanical force on the radio receiver; provide for stress relief.
- Define the installation location together with the operator.

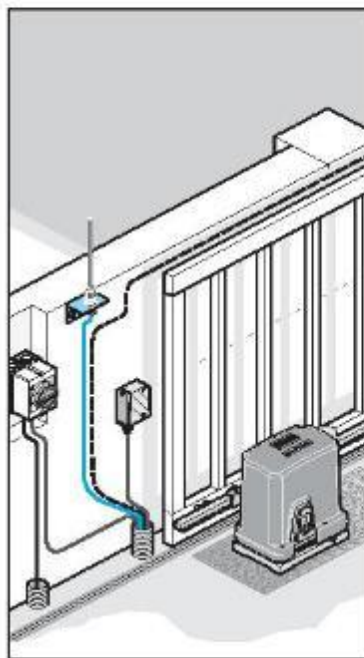

Programming the handheld transmitter



IMPORTANT INFORMATION!

Delete the memory of the radio receiver before the first teach-in of the handheld transmitter.

1. Press the learn button (1).
 - 1 x for channel 1; the LED (3.1) lights up.
 - 2 x for channel 2; the LED (3.2) lights up.
 - ⇒ If no code is sent within 10 seconds, the radio receiver switches to Normal mode.
2. Press the desired handheld transmitter button (5) until the LED (3.1/3.2) extinguishes, depending upon which channel has been selected.
 - ⇒ LED goes out - programming is finished.
 - ⇒ The handheld transmitter has transferred the radio code to the radio receiver.
3. Repeat the above steps to program by teach-in any additional handheld transmitters. A maximum of 112 storage locations for each radio receiver are available.

Cancelling the teach-in mode:

Press the Learn button (1) until no more LEDs are lit.

Deleting the handheld transmitter from the radio receiver

If a handheld transmitter is to be deleted from the radio receiver, **every** button and **every** short cut of the handheld transmitter must be deleted for security reasons!

1. Press the teach-in button (1) and keep it pressed for 5 seconds.
 - ⇒ An LED flashes (3.1 or 3.2).
2. Release the teach-in button (1).
 - ⇒ The radio receiver is in Deletion mode.
3. Press the transmitter button whose code should be deleted in the radio receiver.
 - ⇒ The LED goes out. The deletion procedure is ended.
4. Repeat the procedure for **all** buttons and shortcuts.

Deleting a channel from the radio receiver

1. Press and hold the teach-in button (1).
 - 1 x for channel 1; the LED (3.1) lights up.
 - 2 x for channel 2; the LED (3.2) lights up.
 - ⇒ After 5 seconds, the LED flashes (3.1 or 3.2).
 - ⇒ After another 10 seconds, the LED lights up steadily (3.1 or 3.2).
2. Release the teach-in button (1).
 - ⇒ The deletion procedure is ended.

Deleting the radio receiver memory

If a handheld transmitter is lost, all channels in the radio receiver must be deleted for security reasons. After that, relearn all handheld transmitters.

1. Press and hold the teach-in button (1).
 - ⇒ After 5 seconds, the LED flashes (3.1 or 3.2).
 - ⇒ After another 10 seconds, the LED lights up steadily (3.1 or 3.2).
 - ⇒ After a total of 25 seconds, all LEDs light up steadily (3.1 and 3.2).
2. Release the Learn button (1) – the deletion procedure is ended.

Teach-in by radio (HFL)

Prerequisites for teach-in by radio

At least one handheld transmitter has been programmed by teach-in via the radio receiver (see Teach-in of handheld receivers).

Restrictions

The following is not possible for teach-in by radio:

- The targeted teach-in of a selected handheld transmitter button on a radio channel
- Deletion of a handheld transmitter, radio channel or of the entire radio receiver (memory)
- Changing the programming of a handheld transmitter programmed by teach-in by radio (e.g. teach-in of another button)

Properties:

- Each handheld transmitter that has already been programmed by teach-in can put the radio receiver into teach-in mode by radio.



IMPORTANT INFORMATION!

Radio receivers that are within the range of the handheld transmitter are put into teach-in mode simultaneously.

- The key assignment of handheld transmitter (A) that put the radio receiver into teach-in mode by radio is used for the new handheld transmitter (B) that is to be programmed by teach-in. Example: Button 1 on channel 1 and button 2 on channel 2 has been programmed by teach-in by handheld transmitter (A).
- The new handheld transmitter (B) that has been programmed by teach-in has acquired the key assignment of handheld transmitter (A):
- Button 1 on channel 1 and button 2 on channel 2.

Procedure

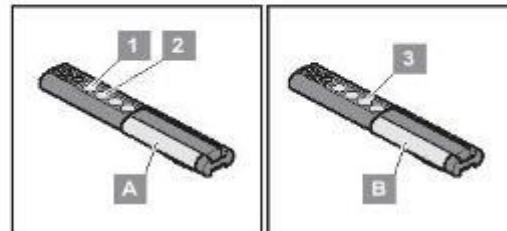

1. Press buttons 1 + 2 of a handheld transmitter programmed by teach-in (A) for 5 seconds until LED channel 1 lights up on the radio receiver.
 - ⇒ If no code is transmitted within another 10 seconds, the radio receiver switches over to normal mode.
 - ⇒ To interrupt teach-in mode: Press button (1), LED channel 1 goes out.
2. Release buttons 1 + 2 of the handheld transmitter (A).
3. Press any key, e.g. (3) on the new handheld transmitter button (B) to be programmed by teach-in.
4. LED channel 1 on the radio receiver flashes initially and then goes out.
 - ⇒ Handheld transmitter (B) has been programmed by teach-in.

Functions

DIP switches



NOTE

Before switching the DIP switches, disconnect the power supply to the control unit. DIP switches are read again when the controller is connected to the power supply again.

Factory setting: OFF

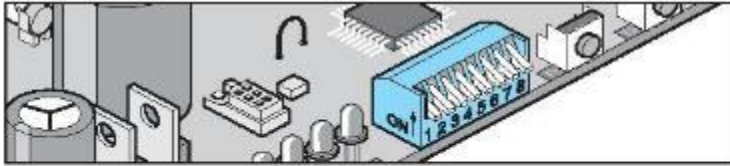

DIP	Position	Function/reaction
Safety connection 1, terminal 6 + 7; action of operator on gate open		
1.	OFF	No reaction by operator
	ON	Operator reversed
Safety connection 1, terminal 6 + 7; selection of function as NC contact or 8.2 kohm		
2.	OFF	NC contact (e.g. photo cell)
	ON	8.2 kohm
Safety connection 2, terminal 8 + 9; action of operator on gate close		
3.	OFF	Operator stops and opens the gate slightly, reversion
	ON	The operator stops and opens the gate completely.
Automatic closing: the gate closes 5 seconds after actuation of the photo cell (safety connection 1 or 2).		
4.	OFF	Deactivated
	ON	Activated
Prewarning time for warning light connection terminal 16 + 17		
5.	OFF	Prewarning time 0 sec.
	ON	Prewarning time 3 sec. – warning light flashes
Fraba system		
6.	OFF	Deactivated
	ON	Activated
Defined opening and closing		
7.	OFF	Pulse sequence with 1-channel mode button/radio channel 1 + 2 : OPEN - STOP - CLOSE - STOP - OPEN - STOP - CLOSE - etc.
	ON	Pulse sequence with 2-channel mode button/radio channel 1: OPEN - STOP - OPEN - STOP - OPEN etc. button/radio channel 2: CLOSED - STOP - CLOSED - STOP - CLOSED - etc.
Partial opening		
8.	OFF	Partial opening deactivated
	ON	Partial opening activated button/channel 1 = OPEN - STOP - CLOSED - etc. button/channel 2 = partial opening DIP switch 7 OFF

Obstacle detection (DIP 1, 2 + 3)

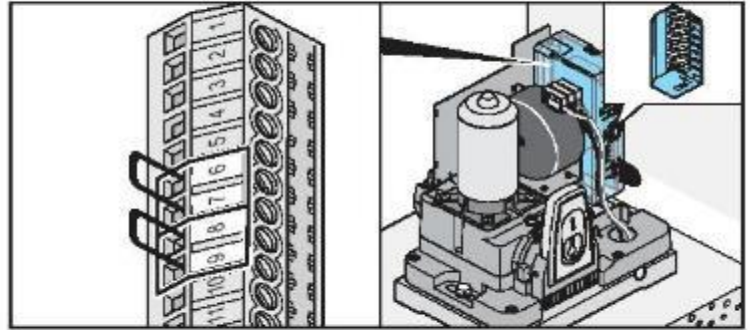

Obstacle when gate is opening

Force cut-off

Operator reversed

Safety input 1, terminal 6 + 7

If a safety input is interrupted (e.g. someone passes through the photo cell), the operator detects this and reacts according to the setting of DIP switch 1.

DIP switch 1:

OFF No reaction by operator

ON Operator reverses

DIP switch 2: Safety connection 1, terminals 6 + 7, function

OFF NC contact, e.g. for photo cell

ON 8.2 kohm (safety contact strip)

Safety input 2, terminals 8 + 9

No reaction by operator

Obstacle when gate is closing



IMPORTANT INFORMATION!

When automatic closing is activated the gate always opens completely.

Force cut-off

Operator reversed

Safety input 1, terminal 6 + 7

If a safety input is interrupted (e.g., someone passes through the photo cell), the operator detects this and reacts according to the setting of DIP switch 3.

DIP switch 3:

OFF Operator stops and opens the gate slightly, reversion.

ON The operator stops and opens the gate completely.

Safety input 2, terminals 8 + 9

DIP switch 3:

OFF Operator stops and opens the gate slightly, reversion.

ON The operator stops and opens the gate completely.

Functions

Automatic closing function



ATTENTION!

Risk of injury during automatic closing. Automatically closing gates may injure persons within the range of movement of the gate when closing. Always install a photo cell before activating the function. This is a legal requirement.



IMPORTANT INFORMATION!

When using the automatic close function, ensure compliance with standard EN 12453 (e.g. install photo cell 1). Connect an additional photo cell to safety connection 2. It reacts only when the gate is closing.



IMPORTANT INFORMATION!

Operation with automatic closing must comply with EN 12453.



IMPORTANT INFORMATION!

There are two types of automatic closing. Both allow the open holding time to be set from 1–120 seconds.

1. Semi-automatic closing function

2. Fully automatic closing function



IMPORTANT INFORMATION!

A warning light connected to warning light connection 1 (terminal 16 + 17) flashes during automatic closing.



IMPORTANT INFORMATION!

With the exception of some regions, the fully automatic closing function is set by default.

The type of automatic closing function can only be changed using TorMinal (see the current TorMinal instructions).

Fully automatic closing function

- All commands are ignored during opening
- When the gate OPEN end position or the programmed partial opening position is reached, the open holding time (OHT) starts
- If a pulse command is received (e.g. START button or radio channel 1), the OHT is restarted
- If an new partial opening command is received at the "partial opening" operator setting, the OHT is restarted

Semi-automatic closing function

- All commands from command transmitters are accepted
- When the gate OPEN end position or the programmed partial opening position is reached, the open holding time starts (referred to as OHT below)
- The gate closes on expiration of the OHT
- If a pulse command is received (e.g. START button or radio channel 1), the OHT is reduced
- The OHT is reduced if a partial opening command is received
- The OHT does not expire at an intermediate stop



IMPORTANT INFORMATION!

Partial opening and automatic closing
Use both functions together, first partial opening (DIP 8 ON) and then adjust automatic closing.

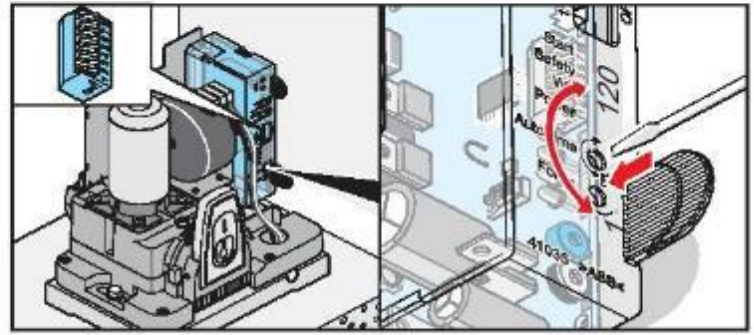

Switch open hold time on and off with potentiometer:

- Time can be set from 1–120 seconds
- Switch off -> left stop

Behaviour of operator when safety inputs 1 + 2 are triggered

When gate is opening:

Operator behaviour depending on setting of DIP switch 1.

When gate is closing:

operator always opens gate completely, regardless of the setting of DIP switch 3.

Variant 1: Automatic closing function

Automatic closing is activated when the gate OPEN end position is reached. The stay-open time set with the potentiometer starts at this point. If a command is sent during this period, the time is reset.

Settings:

- Set the potentiometer for the desired time (1–120 seconds)
- DIP switch 4, 7 + 8 OFF
- other DIP switches as desired

Variant 2: Automatic closing + photo cell (DIP 4)



IMPORTANT INFORMATION!

Install a switch in the photo cell supply line for manual interruption of automatic close.



IMPORTANT INFORMATION!

If a photo cell event occurs during the automatic closing function, the operator reverses completely.

However, as in type 1, the operator closes the gate 5 seconds after interruption of the photo cell.

- Photo cell at safety connection 2 (terminal 8 + 9)

Settings:

- Set the potentiometer for the desired time (1–120 seconds)
- DIP switch 7 + 8 OFF
- DIP switch 4 ON
- other DIP switches as desired

Variant 3: Automatic closing + safety contact strip + photo cell



IMPORTANT INFORMATION!

Install a switch in the photo cell supply line for manual interruption of automatic close.

However, as in type 1, the operator closes the gate 5 seconds after interruption of the photo cell.

- Safety contact strip at safety connection 1 (terminal 6 + 7)
- Photo cell at safety connection 2 (terminal 8 + 9)

Functions

Settings:

- Set the potentiometer for the desired time (1–120 seconds)
- DIP switch 7 + 8 OFF
- DIP switches 2, 4 ON
- Other DIP switches as desired

Prewarning time (DIP 5)

A warning light connected to warning light connection 1 (terminal 16 + 17) flashes for 3 seconds after pressing the button or the handheld transmitter before the operator starts.

The prewarning time is cancelled if a button or handheld transmitter is actuated again.

DIP switch 5

- OFF Deactivated
ON Activated, warning light 1 flashes for 3 seconds

Fraba system (DIP 6)

The function of safety connection 1 (terminal 6 + 7) can be switch to evaluation of the signal of a Fraba system here.

DIP switch 6

- OFF Deactivated
ON Activated

Defined opening and closing (DIP 7)



IMPORTANT INFORMATION!

A combination of defined opening/closing function and automatic closing function is possible.

Button/channel 1 open and button/channel 2 close the gate. The 2-channel mode can also be used with only 2 buttons or with handheld remote controls.

Requirement: DIP switch 8 OFF, 2 buttons connected or 2 handheld transmitter buttons programmed.

DIP switch 7

- OFF Deactivated
ON Activated

Partial opening (DIP 8)



IMPORTANT INFORMATION!

A combination of defined partial opening function and automatic closing function is possible.

Depending on the setting, this function partially opens the gate.

Example:

open the gate for persons to pass through. Partial opening can be used with two buttons or by radio (handheld transmitter, Telecody, etc.).

DIP switch 8

- OFF Deactivated
ON Activated, DIP switch 7 non-functional

Partial opening with 2 buttons

Install additional button and connect to terminals 4 + 5 as button 2.

Button 1 always opens the gate completely.

If the gate is partially opened with button 2, pressing button 1 opens the gate completely.

Button 2 performs the partial opening only if the gate is closed.

If the gate is to be completely opened with button 1 or partially opened with button 2, pressing button 2 again closes the gate.

Procedure

1. Close the gate.
2. DIP switch 8 ON: activates partial opening.



IMPORTANT INFORMATION!

Always leave DIP switch 8 set to ON, the OFF setting immediately deletes the set partial opening.

3. Press button 2 (open door from CLOSED end position).
 - ⇒ Door opens until button 2 is pressed again or the door reaches the "door OPEN" end position.
4. Press button 2 once the desired position is reached.
5. Close gate with button 2.
 - ⇒ Partial opening saved and pressing button 2 opens the gate to the saved position.
6. Set DIP switch 8 to OFF to delete the partial opening setting.

Operation

Safety instructions

- Keep children, disabled persons and animals away from the gate.
- Never reach into a moving gate or moving parts.
- Do not drive through the gate until it has been fully opened.
- There is a risk of persons being crushed or cut by the mechanism or sharp edges of the gate.

Opening the gate

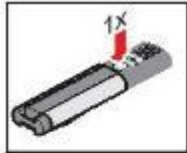

1. Press the pulse transmitter (1) or handheld transmitter button once.
 - If the button is pressed during the gate OPEN movement, the gate stops. Depending on DIP switch 7.
 - It closes when pressed again.

Closing the gate

1. Press button (1) or handheld transmitter button once.
 - If the button is pressed during the gate CLOSE movement, the gate stops. Depending on DIP switch 7.
 - It opens when pressed again.

Emergency release



ATTENTION

Before emergency release always disconnect the power supply to prevent unexpected movements of the gate. Otherwise unexpected movements of the gate may cause injury.



IMPORTANT INFORMATION!

It can be locked and released in any gate position.

Pulse sequence of gate movement

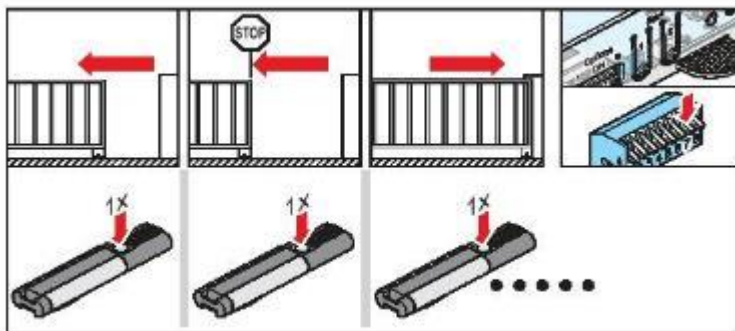

Standard setting for all operators

- DIP 7 OFF:
OPEN - STOP - CLOSE - STOP - OPEN - etc.

Set pulse sequence with DIP switch 7.

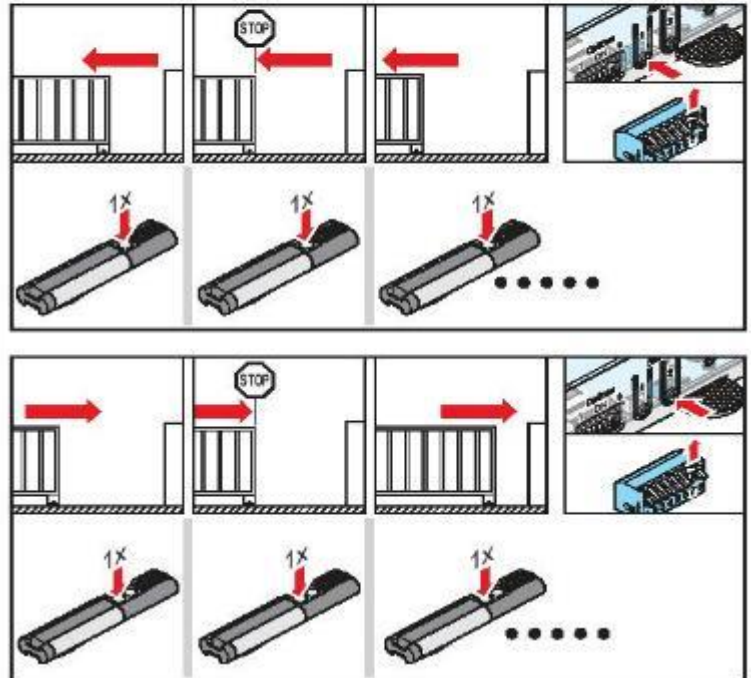

- DIP 7 ON:
Button 1: OPEN - STOP - OPEN - STOP - etc.
Button 2: CLOSED - STOP - CLOSED - STOP - CLOSED - etc.

Control unit reset

All saved values (e.g. runtime, opening force) are deleted; the operator learning process must be repeated.

Resetting the control unit

- see the TorMinal manual to change the maximum speed or shut-off force.
- if the operator learned incorrect values or the gate has been changed.

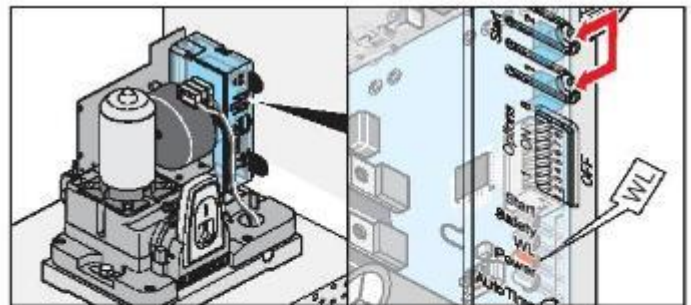

1. Press button (1 + 2) until the "WL" LED is off.
⇒ "WL" LED off – force values deleted.
2. Release button (1+2).

Break-in protection due to automatic lock

If an attempt is made to open the gate with force, the operator presses automatically against it via its motor capacity.

Operation

Emergency release

Releasing the operator

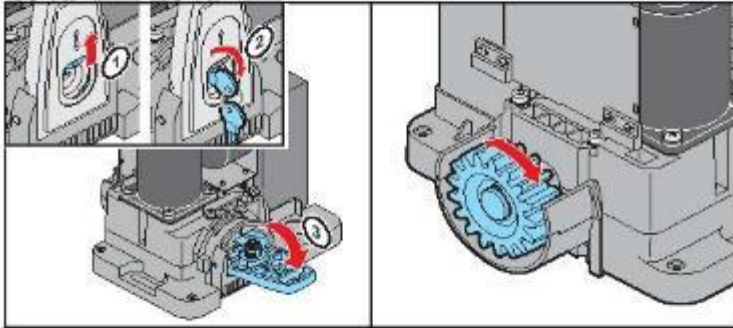

1. Switch off the power supply and secure it against reactivation.
2. Push dust cap (1) upwards.
3. Turn key (2).
4. Open flap.

Locking the operator

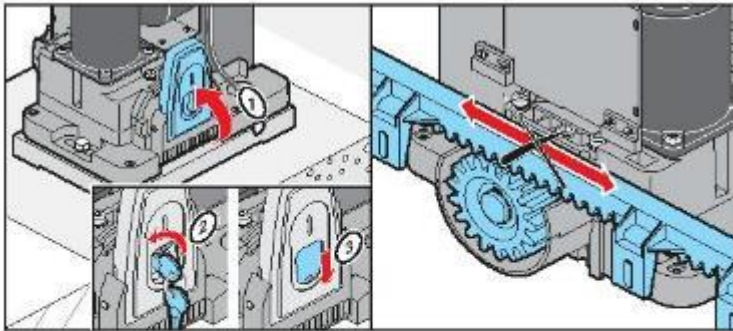

1. Traverse operator to centre position.
2. Lift lever (1) up and lock with key until the motor locks - loud click. Release lever (1).
3. Switch on power supply.



IMPORTANT INFORMATION!

Move gate back and forth by hand so the pinion meshes with the rack more easily and the motor can lock.

⇒ Operator is locked and the gate can only be moved with the motor.

Overload protection

If the operator is overloaded during opening or closing, the control unit detects it and stops the drive.

After about 20 seconds or a control unit reset, the control unit releases the overload protection again. The operator can now resume operation.

Operation after a power failure

The programmed force values are stored in the event of a power failure. The first movement of the operator after a power failure is always gate OPEN.

Stop by obstacle

1. Force cut-off

- when closing the gate -> operator reversed
- when opening the gate -> operator reversed

At the next command the operator moves in the opposite direction, see chapter "Pulse sequence of gate movement".

2. Safety input 1 triggered e.g.: safety contact strip actuated

When the safety input is triggered the operator reacts depending on the setting of the DIP switches. See chapter "Obstacle detection".

Factory settings:

- when closing the gate -> operator reversed
- when opening the gate -> operator reversed

At the next command the operator moves in the opposite direction, see chapter "Pulse sequence of gate movement".

3. Safety input 2 triggered e.g.: Photo cells interrupted

When the safety input is triggered the operator reacts depending on the setting of the DIP switches. See chapter "Obstacle detection".

Factory settings:

- when closing the gate -> operator reversed
- when opening the gate -> no reaction

At the next command the operator moves in the opposite direction, see chapter "Pulse sequence of gate movement".

Operation

Change the fuse

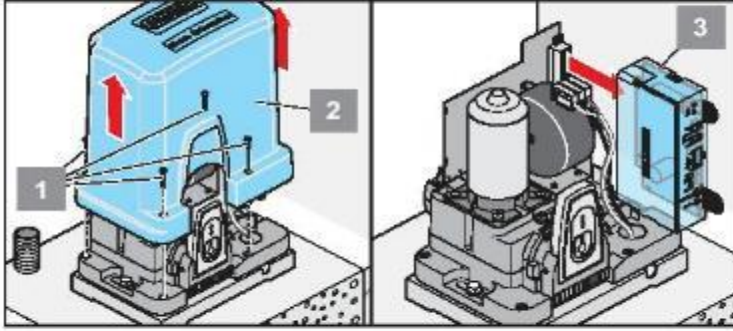

1. Interrupting power supply.
2. Unscrew screws (1).
3. Lift cover.
4. Remove controller (3).

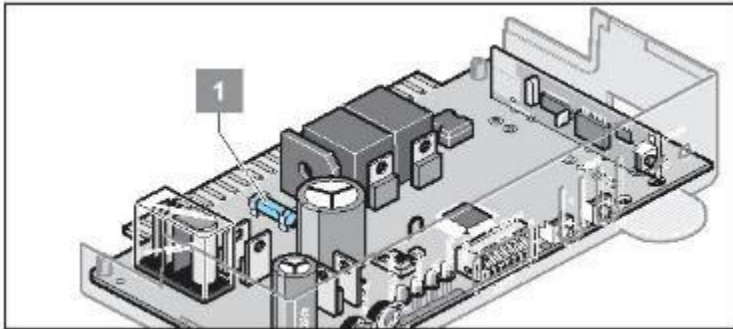
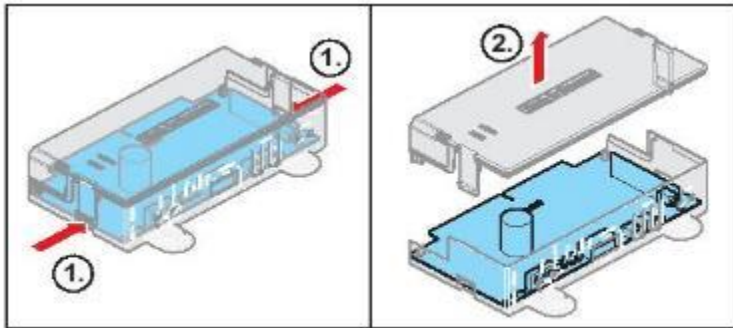

5. Open control unit housing and replace faulty fuse (1).
Fuse "1A – fast-acting" for warning light-1 connection, terminal 16 + 17.

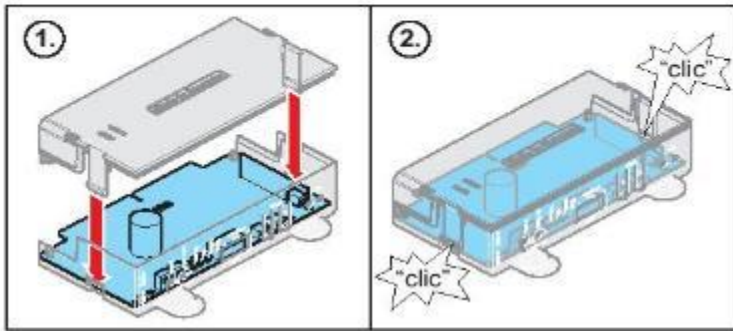

6. Close controller housing.

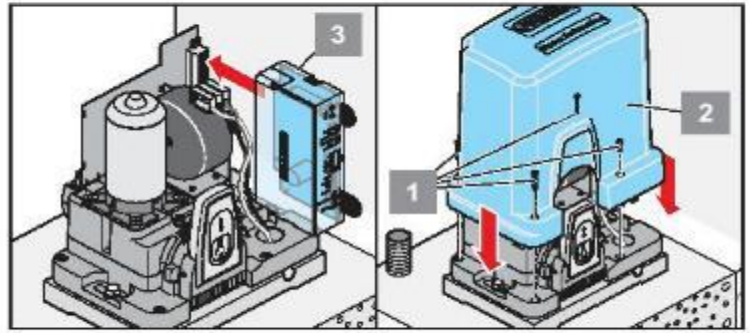

7. Install controller (3).
8. Position cover (2) and fasten.
9. Switch on power supply.

Maintenance and care

Safety instructions



DANGER!

Never use a water hose or high-pressure cleaner to spray down the operator or the control unit housing.

- Before any work on the gate or operator disconnect it from the power supply and lock it to prevent reconnection.
- Do not use acids or alkalis for cleaning.
- Wipe the operator clean with a dry cloth as required.
- Never reach into a moving gate or moving parts.
- Crush and shear hazards at the closing edges and the mechanical systems of the gate.
- Check all fastening screws and bolts of the operator for tight seating and retighten them where necessary.
- Check the gate in accordance with the manufacturer's instructions.

Regular testing

- Check that the safety devices function correctly regularly no less than every 6 months. See EN 12453:2000.
- Check that pressure-sensitive safety devices (e.g. safety contact strip) are operating correctly every 4 weeks (see EN 60335-2-95:11-2005).

Testing	Behaviour	yes or no	Possible cause	Remedy
Force cut-off Try to stop the gate wing while it is closing with a 50 mm wide object.	Does operator reverse when it contacts the object?	Yes	• The force cut-off is functioning.	
		No	• Force tolerance too high, adjust with TorMinal. • Gate incorrectly adjusted.	• Reduce the force tolerance until the test is successful. First open and close the gate completely twice under supervision. See TorMinal owner's manual. • Adjust the gate, call a technician!
Emergency release Proceed as described in the 'Emergency release' section.	The gate must be easily opened and closed by hand. (Gate is balanced)	Yes	• Everything is OK!	
		No	• Emergency release defective. • Gate jams.	• Repair emergency release. • Check the gate, see maintenance instructions for the gate.
STArter+: Safety contact strip, (optional for STArter, if present) Open and close the gate and actuate the strip at the same time.	Adjust the behaviour of the gate, as set with DIP switch 1, 2 or 3. Safety LED lights continuously.	Yes	• Everything is OK!	
		No	• Cable breakage, terminal loose. • DIP switch adjusted. • Strip defective.	• Check the wiring; retighten the terminals. • Setting the DIP switches. • Decommission the system and lock it to prevent reactivation. Then, contact customer service.
Photo relay, if present Open and close the door while interrupting the photo cell.	Adjust the behaviour of the gate, as set with DIP switch 1, 2, or 3. Safety LED lights continuously.	Yes	• Everything is OK!	
		No	• Cable breakage, terminal loose. • DIP switch adjusted. • Photo relay dirty. • Photo cell maladjusted (holder bent). • Photo cell defective.	• Check the wiring; retighten the terminals. • Setting the DIP switches. • Clean the photo cell. • Adjust photo cell. • Decommission the system and lock it to prevent reactivation. Then, contact customer service.

Disassembly



IMPORTANT!

Observe the safety notices!

The sequence is identical to that described in the "Installation" section, but in reverse order. Ignore the setting instructions.

Disposal

Observe applicable national regulations.

Warranty and customer service

The warranty complies with statutory requirements. The contact person for warranties is the specialist retailer. The warranty is only valid in the country in which the operator was purchased.

Batteries, fuses and bulbs are excluded from the warranty.

If you require after-sales service, spare parts or accessories, please contact your specialist retailer.

We have tried to make the Installation and Operating Instructions as easy as possible to follow. If you have any suggestions as to how we could improve them or if you think more information is needed, please send your suggestions to us:

Fax: +49 (0) 7021/8001-403

E-mail: doku@sommer.eu

Troubleshooting

Tips on troubleshooting



IMPORTANT!

Many malfunctions can be resolved by a control unit reset (delete force values), then reprogram the operator.

If you cannot find the malfunction in the table and eliminate it, take the following action:

- Disconnect connected accessories (e.g. photo cells) and reconnect the jumper for a safety connection.
- Set all DIP switches to the factory setting.
- Set potentiometer to the factory setting (centre position).
- If settings have been changed using TorMinal, perform the control unit reset with TorMinal.
- Check all connections on the direct connectors and terminal strip and retighten if necessary.

If this does not help, contact your specialist dealer for assistance or consult our website at <http://www.sommer.eu>.

Malfunction	Possible cause	Corrective action
Gate does not open or close.	• No mains voltage, LED power light off.	Check the supply line fuse. Switch on main switch.
	• Controller not installed.	Install controller.
	• Fuse for power circuit tripped, power LED off.	Replace circuit breaker. Check circuit with a different consumer device (e.g. electric drill).
	• Controller incorrectly installed.	Plug controller correctly into terminal strip.
	• Automatic closing function activated.	The gate closes automatically after the set time has expired. Switch off automatic closing, turn potentiometer completely anticlockwise.
	• Photo cell interrupted, Safety LED on.	Remove interruption.
	• Safety contact strip (8.2 kohm) Defective or DIP switch 2 OFF. • Safety LED lights continuously.	Replace safety contact strip or set DIP switch 2 to "ON".
	• Optoelectronic safety contact strip switched on but photo cell or safety contact strip (8.2 kohm) connected, safety LED on	Switch off the optoelectronic safety strip; set DIP switch 6 to OFF.
Gate does not open or close when a handheld transmitter or Telecody is actuated.	• The battery is flat; the LED on the handheld transmitter does not light.	Replace battery with new one.
	• The handheld transmitter or Telecody has not been learned on the radio receiver.	Program the handheld remote control or Telecody.
	• Incorrect radio frequency.	Check frequency.
	• The command is constantly pending because the button of the handheld remote control is stuck. Start LED and LED on handheld transmitter on.	Release key or replace handheld transmitter or Telecody.
Gate does not open or close when actuated with a button (e.g. key switch).	• Button not connected or defective. Start LED does not come on when button is pressed	Connect button or replace it.
	• A constant signal is pending – water in the button housing; Start LED on.	Replace button and protect against moisture.
Gate stops while closing, moves about 10 cm in the opposite direction, and stops.	• Force cut-off actuated by an obstacle.	Remove obstacle, open gate completely.
	• Incorrect force values programmed or force tolerance set too low.	Delete force values and reprogram. Only if this does not help increase the force tolerance.
	• End switch magnet incorrectly adjusted, gate travels to block.	Adjust end switch magnet, see chapter "Adjusting gate CLOSE + OPEN end positions".
	• Gate incorrectly adjusted or defective.	Have gate adjusted or repaired by a technician.
Gate stops while opening, moves about 10 cm in the opposite direction and stops.	• Force cut-off actuated by an obstacle.	Remove obstacle. Move gate completely to gate close with button.
	• Incorrect force values programmed or force tolerance too low.	Delete force values and reprogram. Only if this does not help increase the force tolerance. Possible only with TorMinal, see TorMinal manual.
	• Limit switch magnet incorrectly adjusted.	Adjust end switch magnet, see chapter "Adjusting gate CLOSE + OPEN end positions".

Troubleshooting

Malfunction	Possible cause	Corrective action
Gate stops while opening.	<ul style="list-style-type: none"> Connected photo cell interrupted and DIP switch 1 ON. 	Eliminate interruption or turn DIP switch 1 to OFF.
Operator does not close the gate.	<ul style="list-style-type: none"> Photo cell power supply interrupted. 	Check connection. Replace fuse.
	<ul style="list-style-type: none"> Operator has been disconnected from mains power supply. 	The operator always opens the gate completely upon first command after the power supply has been restored.
Operator opens gate, then no further reaction more on a command with button or transmitter.	<ul style="list-style-type: none"> Safety input triggered (e.g. photo cell defective), safety LED on. 	<ul style="list-style-type: none"> Remove object from light barrier. Repair photo cells. Control unit not properly plugged in.
Connected warning light doesn't light up.	<ul style="list-style-type: none"> Defective fuse. 	Replace fuse; see chapter "Maintenance and care".
	<ul style="list-style-type: none"> Defective light bulb. 	Replace bulb.
Speed varies during opening and closing.	<ul style="list-style-type: none"> Operator starts and slows down before reaching the limit position. 	Completely normal, operator starts at maximum speed. The operator reduces speed before reaching the other limit position (soft running).
Gate can only be operated with the buttons, e.g. key button, held down – the internal lights flash during this process (dead man's operation).	<ul style="list-style-type: none"> Dead man button mode switched on. 	Deactivate dead man function; see the TorMinal manual.
Start LED lights up continuously.	<ul style="list-style-type: none"> Continuous signal at button connection 1 or 2. 	Check connected button (key switch if connected).
	<ul style="list-style-type: none"> Continuous signal from radio receiver, LED 3.1 or 3.2 on radio receiver on. Radio signal is being received; button of handheld remote control might be defective or an external signal is being received. 	<ul style="list-style-type: none"> Remove the battery from the handheld transmitter. Wait until the external signal falls off.
Only radio receiver!		
All LEDs flashing.	<ul style="list-style-type: none"> All memory locations occupied, max. 112. 	<ul style="list-style-type: none"> Delete any transmitters that are no longer needed. Install additional radio receivers.
LED 3.1 or 3.2 lights up continuously.	<ul style="list-style-type: none"> The radio signal is being received; the button of a handheld remote control may be defective or an external signal present. 	<ul style="list-style-type: none"> Remove the battery from the handheld transmitter. Wait until the external signal falls off.
LED 3.1 or 3.2 lights up.	<ul style="list-style-type: none"> The radio receiver is in the Learning mode and awaiting a radio code from a handheld remote control. 	Press the desired handheld transmitter button.

Connection diagram

