

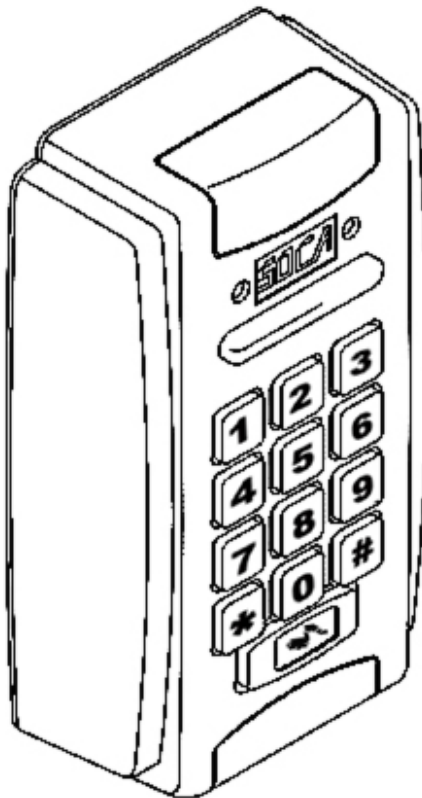

ST-320

**WATER-PROOF PROXIMITY ACCESS
CONTROL SYSTEM OPERATION AND
INSTALLATION MANUAL**



SOCA TECHNOLOGY CO., LTD.

2000 November

CONTENTS

I. SPECIAL FEATURES.....	2
II. FRONT PANEL AND TYPES OF CARDS.....	2
III. INSTALLATION PROCEDURES.....	4
IV. SETTING MODE AND FUNCTIONS.....	5
1. Registration of card (Add one card).....	5
2. Deletion and loss of card (Delete one card).....	6
3. Change of 8 sets of user's passwords.....	6
4. Door lock time setting (shunt time).....	7
5. Setting identification modes.....	7
6. Batch registration (add series cards).....	8
7. Anti-tamper output setting.....	8
8. Changing system password (command).....	9
9. Deletion of 8 sets of user's passwords.....	9
10. Deletion of batch registration (Delete all cards).....	10
11. Door opening (using system password).....	10
12. The Duress Code Setting.....	10
V. INSTALLATION OF PROXIMITY READER.....	11
1. Connections.....	11
2. Installation of electric lock and exit push button.....	12
3. Installation of door sensor, external relay and siren.....	13
VI. PRECAUTIONS.....	14
VII. TROUBLESHOOTING.....	15

ST-320 Mode Setting

I. SPECIAL FEATURES:

1. One set stand alone design.
2. After installation of proximity reader and is connected to power source, red power indicator on the front panel will light up.
3. 4 types of door opening modes:
 - (1) Enter 4-digit door opening password, identification code is 1.
 - (2) Proximity card door access, identification code is 2.
 - (3) Proximity card plus 4-digit door opening password (8 sets of 4-digit door opening passwords), identification code is 3.
 - (4) Proximity card or 4-digit door opening password, identification code is 4.
4. When entering into the system setting mode, 4-digit system password should be entered in order to enter into system setting modes.

System code is being set at 4567 on production. In order to enter into the system to set up mode, press *# first then enter password and press # again when completed.(Example: *# 4 5 6 7 #).
5. All proximity card or proximity key tag must be registered before use.
6. Proximity card or proximity key tag has 8-digit number code. The card number required for setting is the last 6 digits.
7. 8 sets of door opening passwords.
8. Maximum storage capacity of 2,000 cards.
9. Data memory feature in case of power failure.

II. FRONT PANEL AND TYPES OF PROXIMITY CARD:

FRONT PANEL

1. Indicator lights :
 - (1) KEY light (green) : Green flashing light on when buttons pressed.
 - (2) Status light (green) : Green light on when entering.
2. Bar indicator light :
 - (1) OK light (green bar indicator light): Door open indicator light.
 - (2) Power light (red bar indicator light): System standby.
3. Ten enter keys, two functional keys: “#”, “*”.
 - # key: Confirmation key.
 - * key: Clear or escape key.

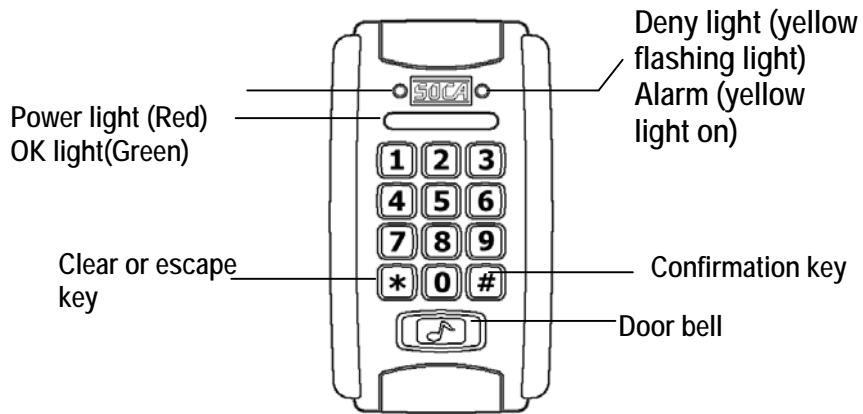

Types of proximity cards

The following 3 types of cards are required to register before use.



SC-10 : Thin card , thickness 0.8 mm,
ISO standard card dimension.
Read range 10 cm. It can be printed
directly from card printer.

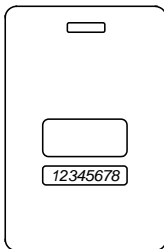

SC-20 : Thick card , thickness 1.8 mm,
ISO standard card dimension.
Read range 10 cm. It can be printed
directly from card printer.

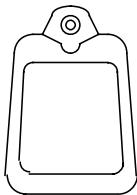

SC-30 : Key tag, read range 6cm.
dimension 5.5L X 7.5H X 3.2W (mm).
Ultrasonic connection, water-proof,
shock- proof.

III. INSTALLATION PROCEDURES

Refer to appendix
(Mounting of reader unit.)

3

Users could install either 6-pin or
8-pin connector to see fit. Please refer
to item 5 in installation guide on page.

IV. SETTING MODES AND FUNCTIONS :

To enter into the system setting mode, first press * #, then enter system password and press # subsequently to enter into system

setting mode. When entered into system setting mode, the STATUS light (green) on the panel will be on with a beep sound.

Users should enter any functional selections within 20 seconds. The reader will automatically terminate the system setting mode function after 20 seconds.

1. Add one card : To register user's card and utilize proximity to register.

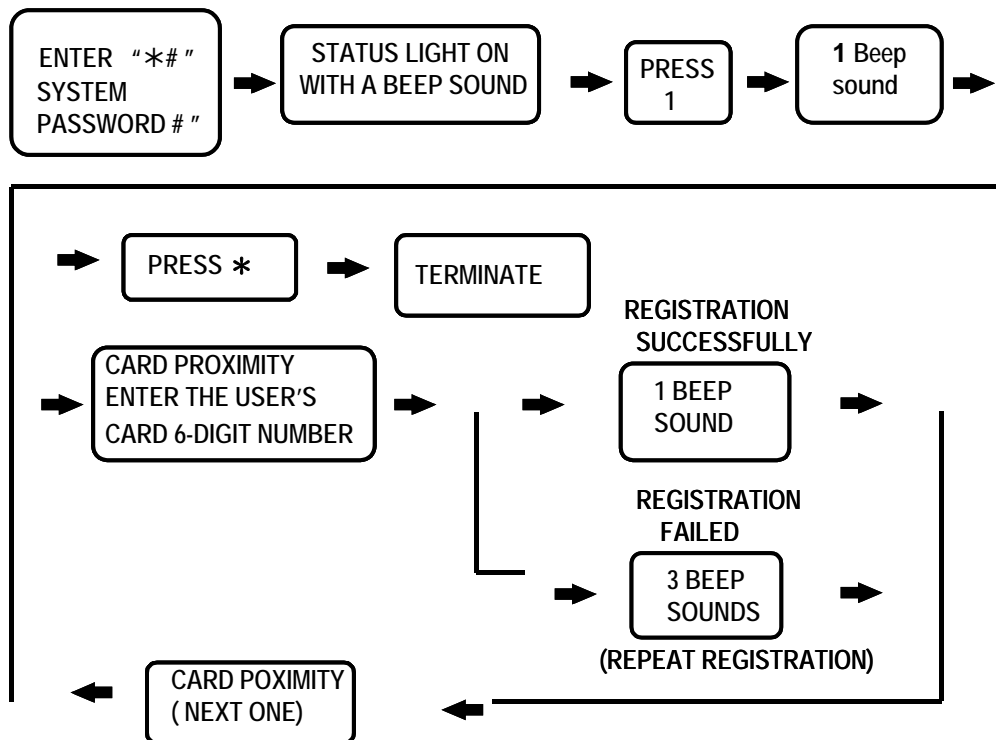

On the above operation, if "*" is being pressed, the card registration activities will be terminated.

2. Delete card : Deletion of user's card (such as loss of card), card number is the 6-digit code indicated on the proximity card.

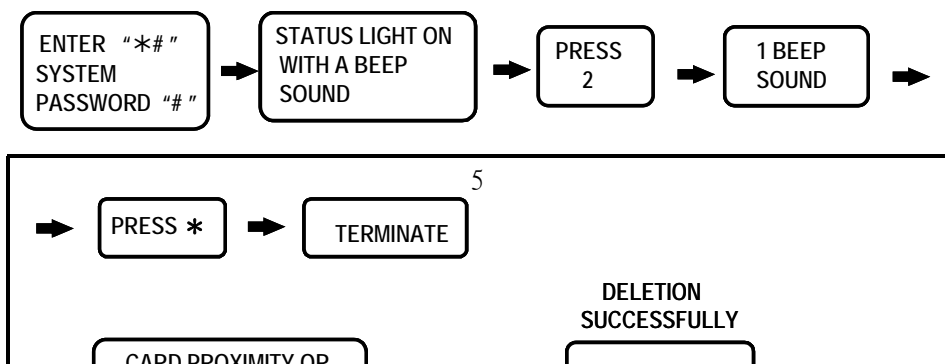

On the above operation if “*” is being pressed, the setting modes will be terminated, provided that there isn’t any key being entered. Any key-in being done prior to this operation will be deleted.

3. Change of 8 sets of user’s password:

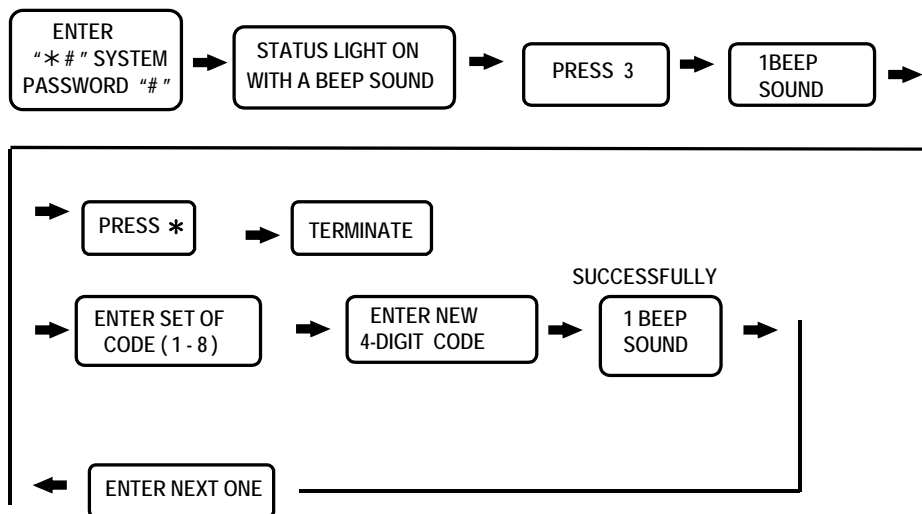

4. Door lock time setting : This setting is to determine its unlock time. Time can be set from 01-99 seconds.

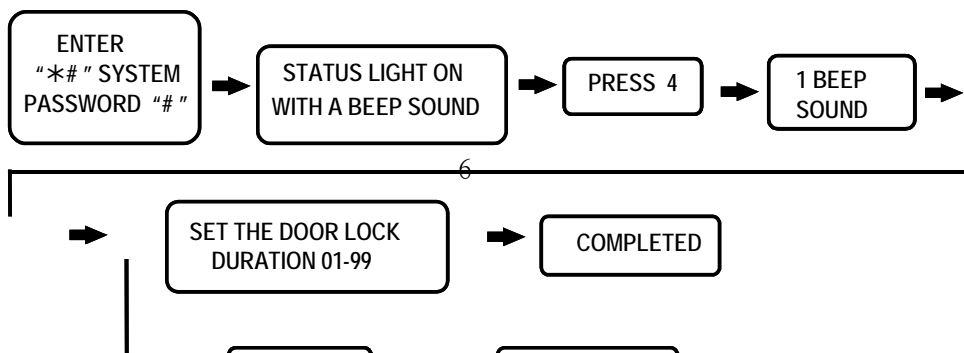

5. Setting identification modes:

There are 4 sets of door-opening modes. Users could only set one of the identification modes for access control. Its identification mode has been preset to proximity card door-opening.

- (1) Door opening based on 4-digit password (There are a total of 8 sets of user's password), mode number is 1.
- (2) Proximity card door opening, that is door will open when the card is sensed, mode number is 2.
- (3) Proximity card and enter 4-digit password door opening, mode number is 3.
- (4) Proximity card or enter 4-digit password door opening, mode number is 4.

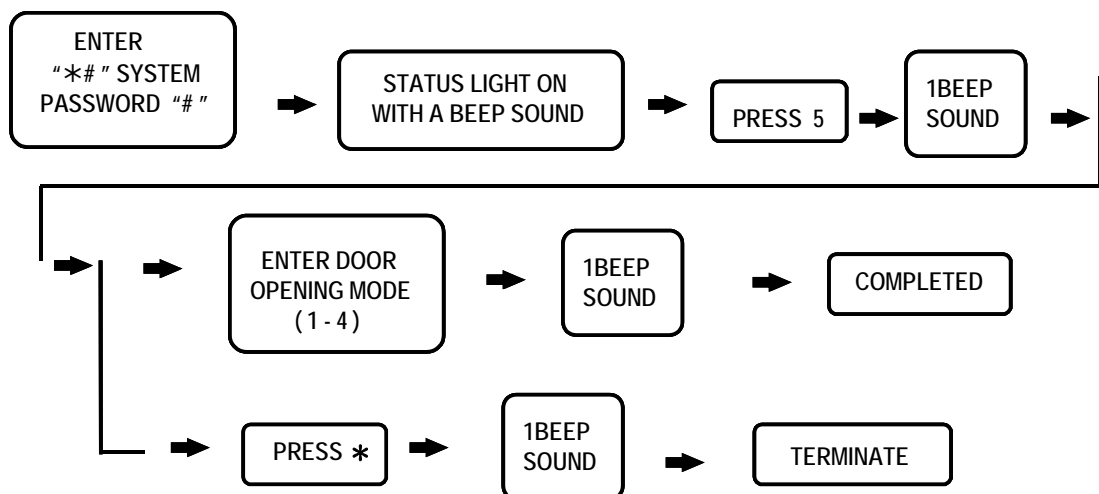

6. Batch registration : To be used for registering multiple cards and cards in series. Enter 6- digit card number, then enter amount of cards, in 4-digit manner (must be in full 4 digits, such as 100 pcs. , enter 0100). This system can also apply to single card entry.

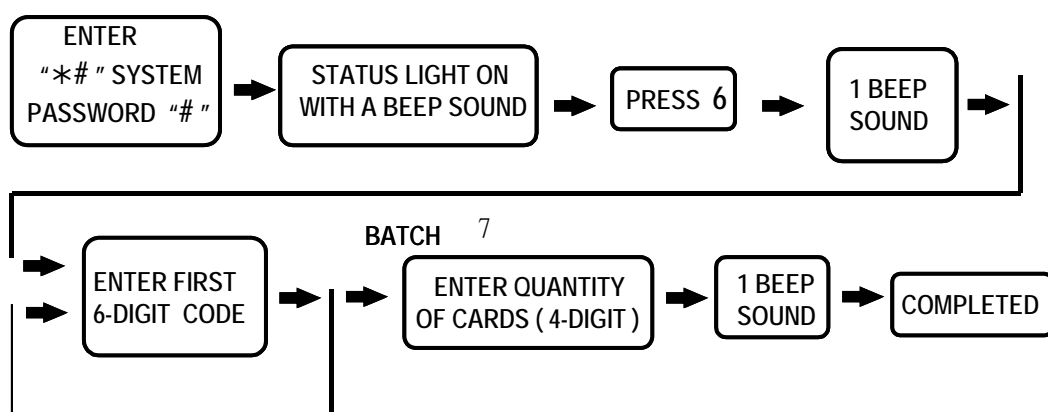

7. Anti-tamper output setting : This reader has an anti-tamper output connecting point. There are two detection sources:
 (1) Damage to the proximity reader(tamper switch).
 (2) Damage to the door (must add detection wiring such as reed switch).

This function can be set whether door detection point is applied to activate the anti-tamper output:

- (1) 0 : ON
- (2) 1 : OFF

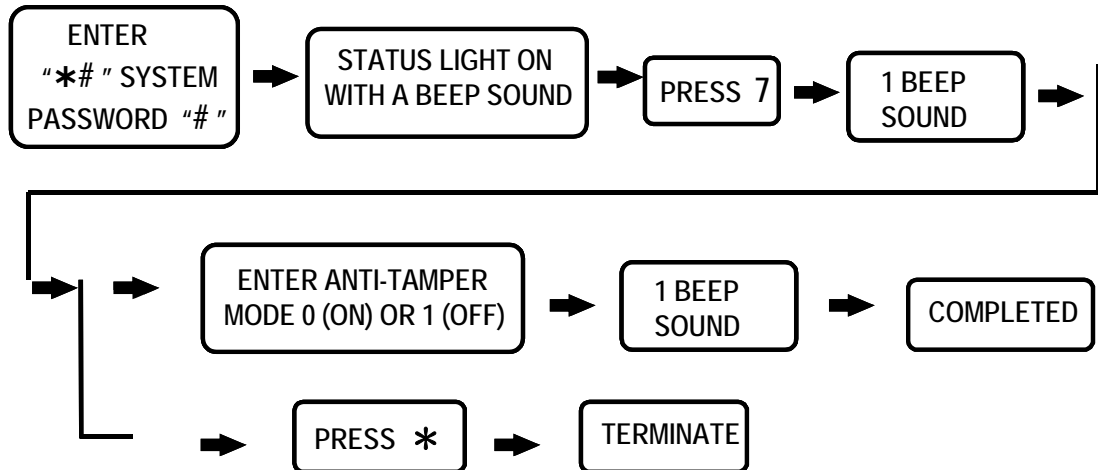

8. Change system password : To change system password, this reader's password is being preset at 4567. Please note that this password is necessary to enter into the system setting mode.

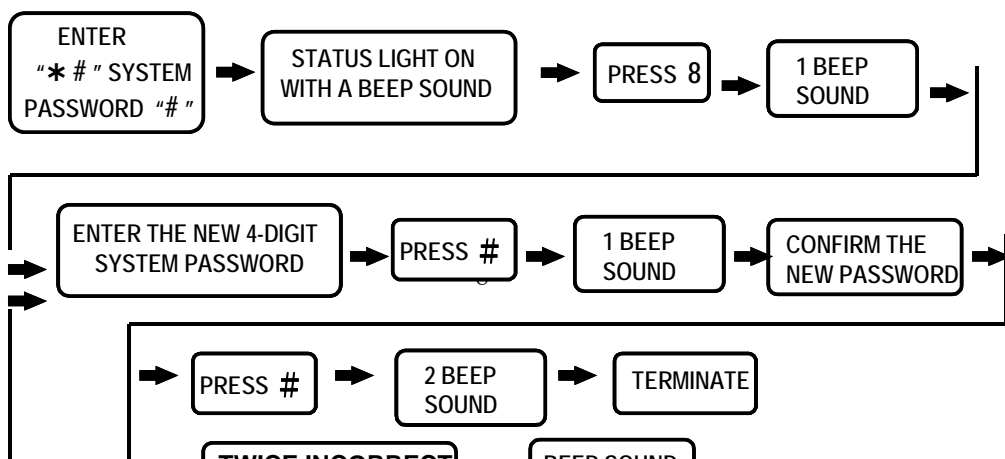

System password has been preset at 4567. Users should enter new 4-digit system password twice to complete change of system password.

9. Deletion of 8 sets of user’s password : Please note that this function will delete all the 8 set of user’s passwords and cannot be retrieved.

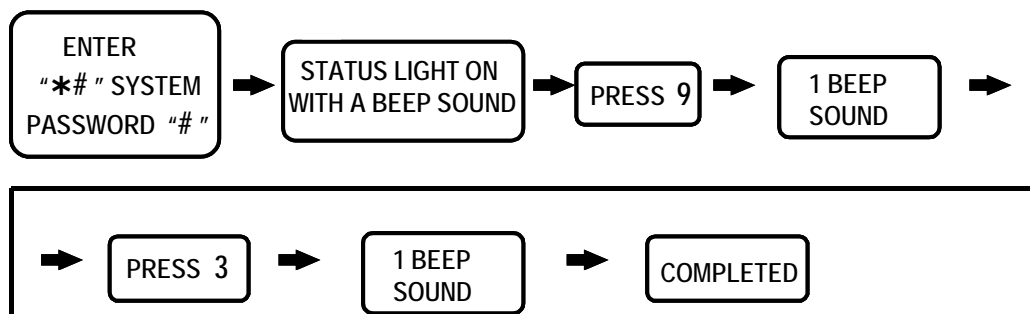

10. Delete all cards : Please note that this function will delete all registered card and cannot be retrieved.

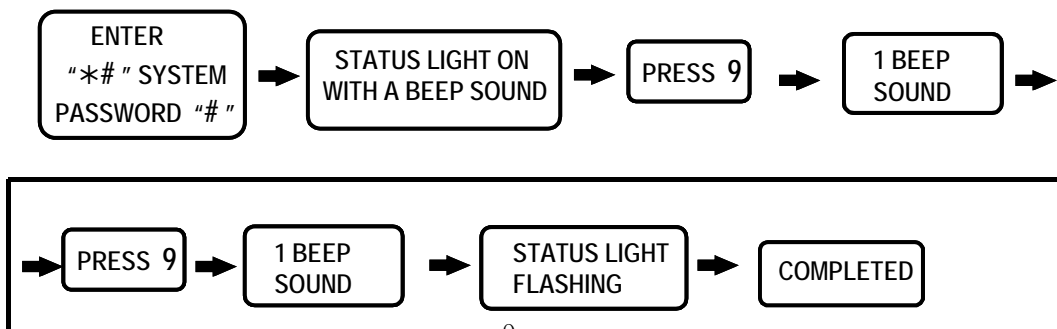

11. Door opening (using system password) :

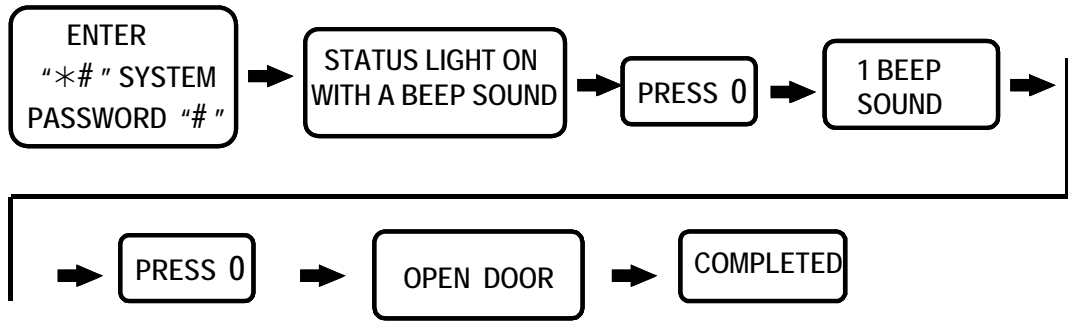

12. The duress code setting:

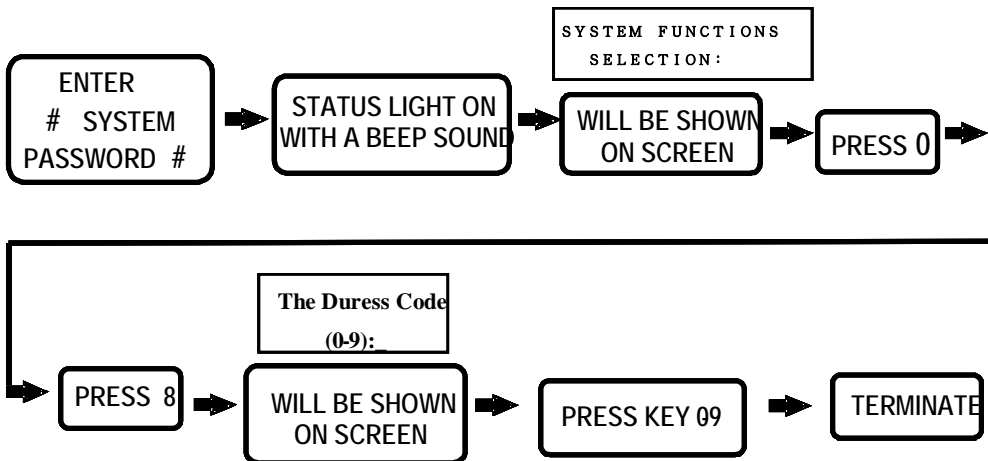

V. INSTALLATION OF PROXIMITY READER :

1. Reader connections :

ST-320 Wiring diagram

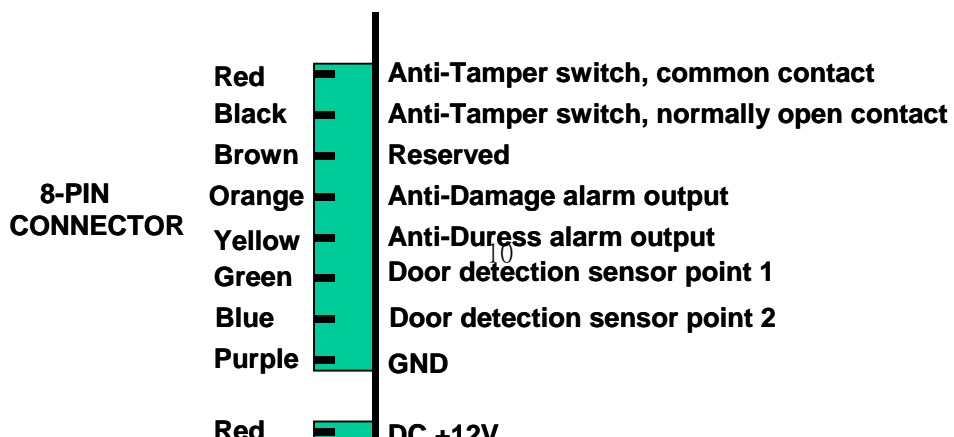

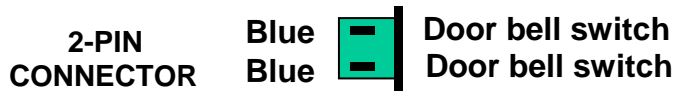

- * Door open relay contact rating DC12V/ 3A
- * Tamper switch contact rating DC24V / 0.5A
- * Door bell switch contact rating AC125V /3A

2. Installation of electric lock and exit push button:

A. Electric lock (fail secure type) and reader .

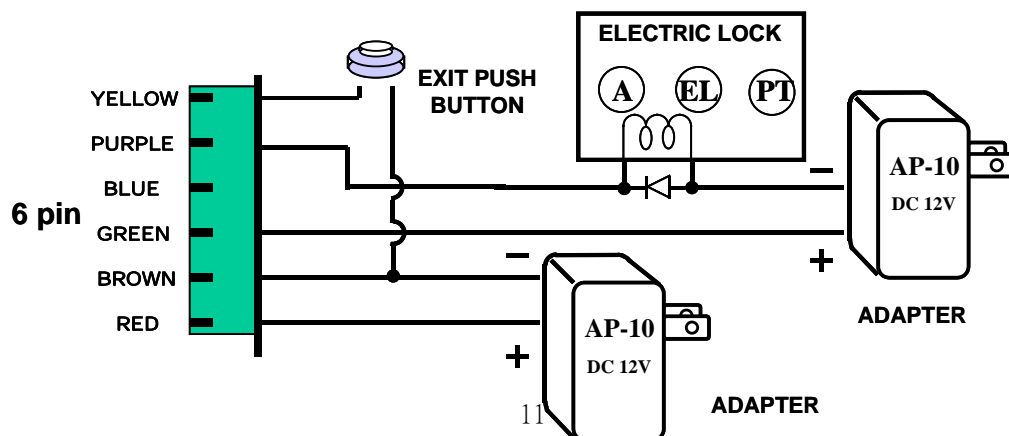

B. Electric lock (fail safe type) and reader .

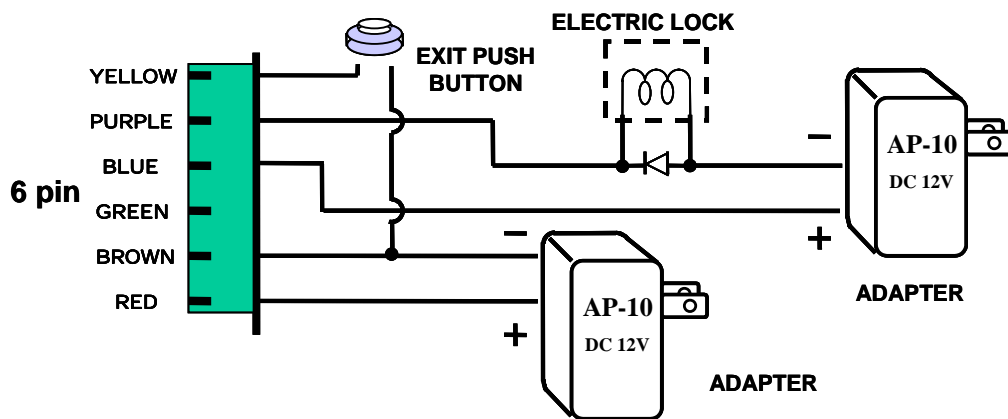

Note: (1)fail-secure type lock : Connect to 6-pin connector, blue and green points.

(2)fail-safe type lock : Connect to 6-pin connector, purple and green points.

(3)exit push button can only be used by dry- contact

3. Installation of door sensor, external relay and siren :

A.Installation of reed switch (normal close), external relay(anti-damage)

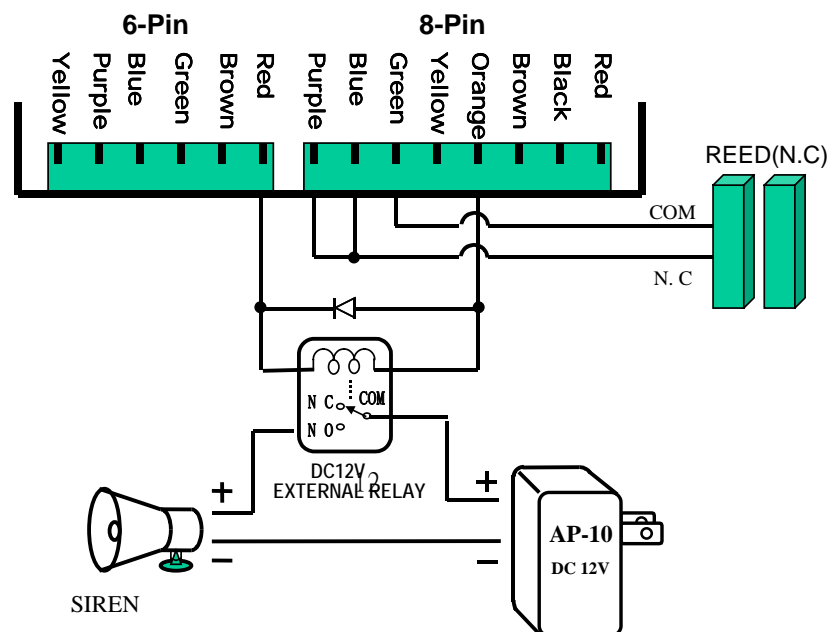

B.Installation of reed switch (normal open), external relay(anti-duress)

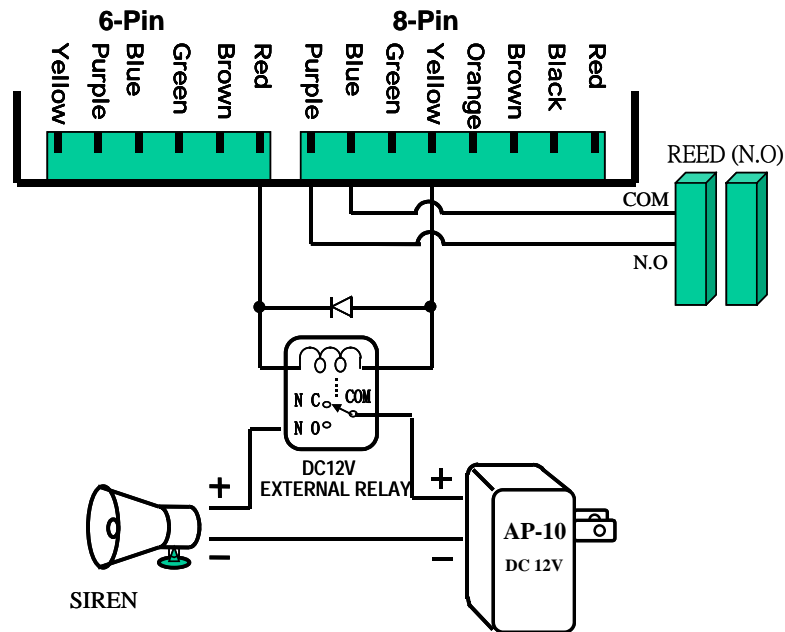

- Note :** (1) Proximity reader provides two external relay connecting points which are :
- A. Anti-damage (tamper switch and door sensor) alarm output connecting point (8P orange connecting point).
 - B. Duress alarm output connecting point (8P yellow connecting point).
- (2) If door sensor detecting (such as reed switch) points are applied, please set ALARM to ON mode.
For setting method, please refer to setting mode functional selection item 7 in the manual.
3. For installation, please link power supply wire and control wire through the base panel first and then fix the base panel onto the wall.
 4. Install the proximity reader on the base panel (power supply wire and control wire must first be inserted and the wires must be arranged correctly), and then use the enclosed key wrench and screws to mount it up.
 5. Power supply: DC 12V 500~800mA.

6. Power consumption, standby 90mA, active 110mA.

7. Dimensions: 125mm (L) X 33mm (W) X 70mm (H).

- * DO NOT SHARE THE SAME POWER SUPPLY OF BOTH ELECTRIC LOCK AND PROXIMITY READER TOGETHER. USERS SHOULD PROVIDE SEPARATE POWER SUPPLY FOR BOTH OF THEM.

VI. PRECAUTIONS :

1. Before installation, please check the voltage and polarity of the power supply in order to avoid wrong connection causing damage to the reader.
2. Please do not share the power supply together with the electric lock and the proximity reader .
3. Please do not install metal product or monitor near this equipment in order to avoid distance proximity.
4. Please do not conduct any repairment or any modification to the system, unless by qualified personnel
5. Warranty period for the reader is 1 year.

VII. TROUBLESHOOTING

1. Card sensed but the door lock doesn't work.

Solution: (1) Please check if the power supply is on the proximity reader and the electric lock.

(2) If (1) is checked, please check the electric lock power supply and whether the connecting points are correct.

(3) Continuous proximity. Please remove the card from the reader and try again.

(4) Please check whether the door opening mode is correct.

3. System password is entered but cannot enter into various functional selection of the setting mode.

Solution : Incomplete input of system password, please check whether the following format has been entered:

#XXXX# (XXXX represents system password), or first press “” then enter valid system password *#XXXX#.

4. How to use the duress code setting?

Solution : (1) Users should change door opening mode to 4-digit password door opening(mode code 1), or proximity card or 4-digit password door opening(mode code 4) in order to enable duress code setting.

(2)After the door opening mode is set (please refer to item 5 of the setting mode functional selection on how to set door opening mode), press “*# The Duress code + 4-digits door opening password #”, then the duress alarm output function will execute.

5. How to terminate anti-damage activation or duress alarm activity?

Solution : Enter into system setting mode or open the door.

6. What is the operation of the door sensor detection (reed switch)?

Solution : If the door sensor detection function is being set at ON (for detail, refer to item 7 of the setting mode functional selection in the manual) and if the door is not closed within 30 seconds, then the anti-damage output function will be activated.

Appendix

Mounting of reader unit:

STEP1:

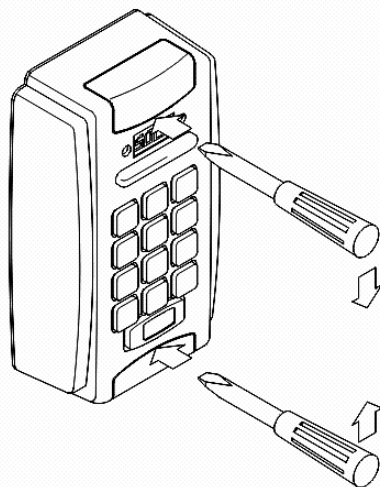

Use screwdriver to dismantle or open the covers of screws at the top and bottom of the reader unit.

STEP2:

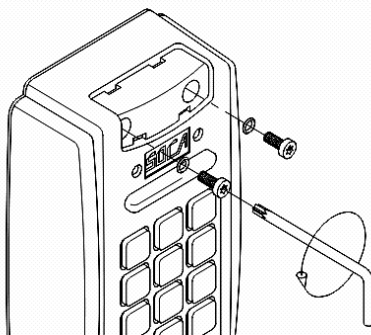

Use enclosed special L-shape spanner to unscrew and remove the special screws anti-clockwise (direction). Please make sure all four O-rings are

STEP3:

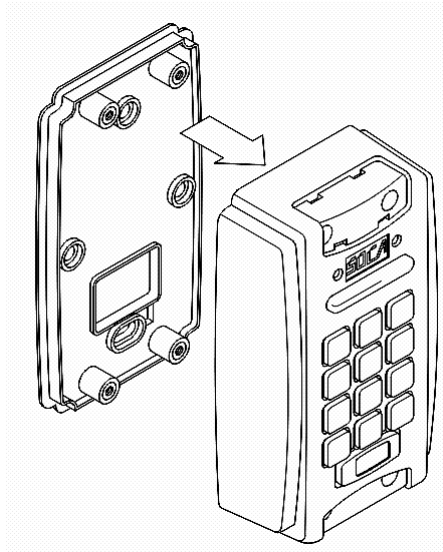

Separate front cover from the base cover.

STEP4:

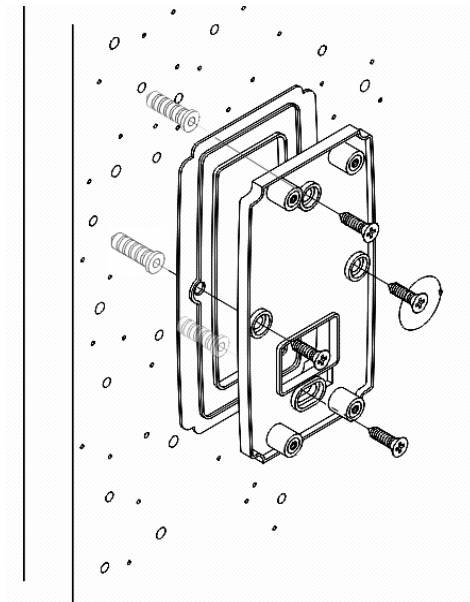

Screw water proof pad with base cover tightly onto the wall.

STEP5:

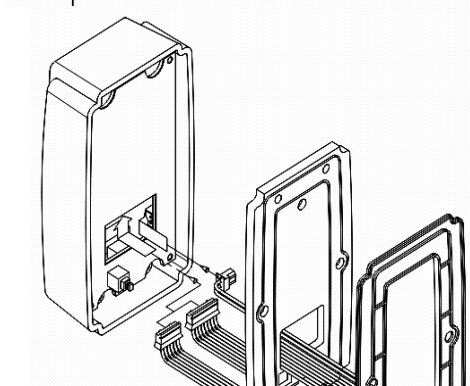

Link connectors through water proof pad and base cover to connect to the reader unit.

STEP6:

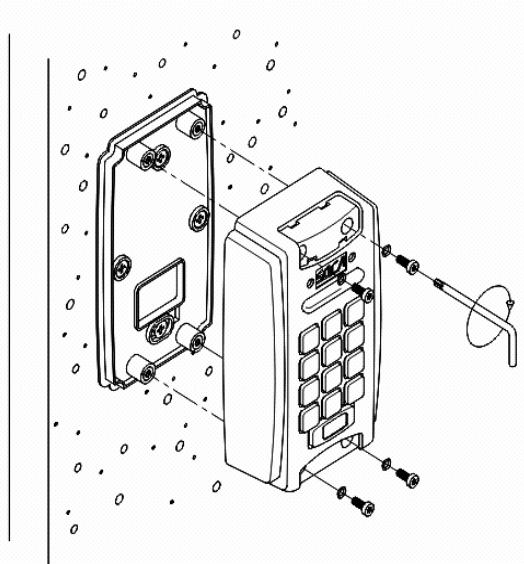

Screw the front cover with base cover tightly with four screws (make sure all four O-rings are fitted to the screws)

STEP7:

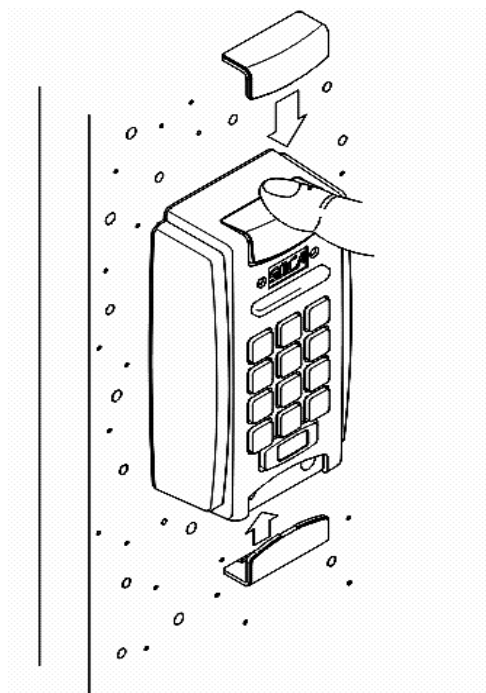

Press the screws covers(top and bottom) firmly.

ATTENTION: (When mounting onto rough wall)
Use appropriate size of flat acrylic or wood piece (Do not use metal piece) to mount onto rough wall with silicon glue. Screw or fit the base cover onto it.

