



## Motorised swing doors

### User manual

(translation of the original instructions)

IP2225EN

# Contents

	<b>Description</b>	<b>Page</b>
1.	General precautions for safe use	17
2.	Responsibility for the product	19
3.	Environmental requisites	19
4.	Operating mode	20
4.1	Safety devices	20
4.2	Emergency exit	20
5.	Technical specifications	20
6.	Operating mode of DAB swing doors	21
7.	Operating mode of SPRINT swing doors	22
8.	Regular safety checks	23
9.	Periodic safety checks to be carried out by qualified personnel	24
10.	Cleaning	24
11.	General accessories	24
12.	Troubleshooting	25

All the rights concerning this material are the exclusive property of Entrematic Group AB. Although the contents of this publication have been drawn up with the greatest care, Entrematic Group AB cannot be held responsible in any way for any damage caused by mistakes or omissions. We reserve the right to make changes without prior notice. Copying, scanning and changing in any way are expressly forbidden unless authorised in writing by Entrematic Group AB.

# 1. General precautions for safe use



- Failure to observe the information in the User Manual may lead to personal injury or damage to the equipment. These instructions must be kept and forwarded to all possible future users of the system.
- The automatic door must only be used for the purpose for which it was designed. Any other use should be considered improper and therefore dangerous. The manufacturer cannot be held responsible for any damage caused by improper, incorrect or unreasonable use.
- Do not use the automation if it needs repairing or adjusting. Disconnect the power supply when carrying out cleaning or maintenance tasks.
- This product must not be used by people (including children) with reduced physical, sensorial or mental abilities, or lack of experience or knowledge, unless they are given proper surveillance and instructions for operating the device by a person responsible for their safety.
- Any cleaning or maintenance intervention by the user must be carried out directly by, or under the supervision of, a person in charge.
- Do not allow children to play or stay near the automatic door. Keep remote controls and/or any other control devices out of the reach of children in order to avoid possible involuntary activation of the automatic door.

## TECHNICAL SPECIFICATIONS OF THE MOTORISED DOOR AND ITS INSTALLATION

**Manufacturer / Installer:**

\_\_\_\_\_  
Name, address, reference person

**Customer / User:**

\_\_\_\_\_  
Name, address, reference person

**Order number:**

\_\_\_\_\_  
Number and date of the customer order

**Model and description:**

\_\_\_\_\_  
Type of door

**Dimensions and weight:**

\_\_\_\_\_  
Dimensions of the passage opening, dimensions and weight of the door wings

**Serial number:**

\_\_\_\_\_  
Unique door identification number (serial number)

**Location:**

\_\_\_\_\_  
Installation address

### LIST OF COMPONENTS INSTALLED

The technical characteristics and performance of the components listed below are shown in the relative installation manuals and/or on the label on the component itself.

**Motor / Drive unit**

\_\_\_\_\_  
Model, type, serial number

**Control panel:**

\_\_\_\_\_  
Model, type, serial number

**Safety devices:**

\_\_\_\_\_  
Model, type, serial number

**Command devices:**

\_\_\_\_\_  
Model, type, serial number

**Radio devices:**

\_\_\_\_\_  
Model, type, serial number

**Other:**

\_\_\_\_\_  
Model, type, serial number

\_\_\_\_\_  
Model, type, serial number

\_\_\_\_\_  
Model, type, serial number

Entrematic produces technologically advanced automatic doors, using carefully tested materials and components to ensure a high quality product.

Like any other technical product, an automatic door needs regular maintenance and servicing in compliance with the relevant safety standards.

## 2. Responsibility for the product

In compliance with the European directives, the following aspects are the responsibility of the system owner or user.

To ensure the system works efficiently and correctly, the manufacturer's indications must be complied with and only qualified personnel must perform routine maintenance on the automatic door.

In particular, regular checks are recommended in order to verify that the safety devices are operating correctly.

In the event of a fault or a malfunction of the automatic door, disconnect the power supply and contact qualified personnel. Do not attempt to repair or intervene directly. Failure to comply with the above may cause a dangerous situation.

It is important to keep a record of all inspection, maintenance and assistance interventions.

## 3. Environmental requisites

Entrematic Group products contain electronic components and may be equipped with batteries containing materials that are harmful for the environment.

Disconnect the power supply before removing the electronic components and battery. Local regulations concerning the disposal of worn products and packaging must be respected. Correct product disposal helps prevent potential harmful consequences for the environment and human health.



To correctly dispose of electrical and electronic equipment, batteries and accumulators, owners/users must take the product to special "recycling centres" set up by the municipal authorities.

## 4. Operating mode

The automatic system for Entrematic swing doors works electronically.

The motor, the control unit, any batteries are all assembled inside a specific aluminium box.

When an opening pulse (for instance from a movement sensor) is received by the control unit, the motor starts up and conveys the movement to the arm that opens the door .

Closure is automatic once the "opening time" has lapsed and the control unit has received no opening or stop command.

In some cases, closure can be forced via a manual command.

The operating modes are various: Low Energy, Push and Go, Power assist, etc.

The user can choose the type of door operation by means of the function selector switch.

### 4.1 Safety devices

To ensure safe transit during closing operations, the door reverses its movement direction if it meets an obstacle. At the following operation, the door resumes the interrupted movement at low speed to verify that the obstacle has been removed.

If an obstacle is detected during the opening operation, the door wings stop immediately and then close after a set delay time.

It is possible to monitor the area of the door movement with motion sensors in order to detect any obstacles.

### 4.2 Emergency exit

The automations for the swing doors can be installed in escape routes.

## 5. Technical specifications





<b>Manufacturer:</b>	Entrematic Group AB			
<b>Address:</b>	Lodjursgatan 10, SE-261 44 Landskrona, Sweden			
<b>Type:</b>	SPRINT PN SPRINT P SPRINT V	SPRINT LN SPRINT L SPRINT LV	DAB105	DAB205
<b>Power supply:</b>	230V~ 50/60 Hz	24V (external fuse)	100-240 V~ +10 /-15% 50/60 Hz	100-240 V~ +10 /-15% 50/60 Hz
<b>Power consumption:</b>	max 120W	max 120W	max 75W	max 300W
<b>Protection class:</b>	IP30	IP30	IP20	IP20
<b>Certifications:</b>	Certifications of third parties, supplied by accredited certification bodies and valid for usage safety. Refer to the Conformity Declaration.			

## 6. Operating mode of DAB swing doors

### 6.1 ON/OFF/HOLD OPEN function selector switch button on the automation





Position	Function	Description
	ON	For two-way door operation.
	OFF	For one-way operation (inner side) of the door.
	HOLD OPEN	Door open. Permanent opening command.

### 6.2 COM400MKB - COM400MHB function selector switch (optional) on automation

Position	Function	Description
	TWO-WAY	For two-way door operation. The electric lock, if present, is open.
	DOOR CLOSED	The door closes and remains closed and blocked (if electric lock is present). The door can be opened with a key-operated switch (if present).
	DOOR OPEN	The door opens and remains open.
	ONE-WAY	For one-way door operation. The door is only locked when an electro-mechanical blocking device is present. The door can only be opened with an internal motion sensor and with a key-operated switch (if present).

## 7. Operating mode of SPRINT swing doors







### 7.1 Function selector switch button for SPRINT V - LV -VJ on automation

Position	Function	Description
		Door open. Permanent opening command.
		Door closed. The opening sensors commands are excluded. The door can be push-opened if the Push and Go function is enabled. The door closes and remains closed if the electric lock is present.
		For two-way door operation.

### 7.2 ON/OFF button for SPRINT P - L - PN - LN - PNJ

Position	Function	Description
	ON	Automation on.
	OFF	Automation off.

### 7.3 COMH-COMK function selector switch

Position	Function	Description
	DOOR OPEN	After an opening command, the door opens and remains open.
	TOTAL ONE-WAY OPENING	For one-way operation from the inner (or outer) side of the door.
	TOTAL TWO-WAY OPENING	For two-way door operation.
	/	NOT ACTIVE
	DOOR CLOSED	The opening sensors commands are excluded. The door can be push-opened if the Push and Go function is enabled. The door closes and remains closed if the electric lock is present.
	NIGHT-TIME CLOSING	With the door closed, it carries out an immediate STOP and stops in its current position.







## 8. Regular safety checks

To meet the national/international requisites and avoid any risk of personal injury or device malfunctioning, the following check-list is supplied.

Do not use when repairs or adjustments need to be carried out.



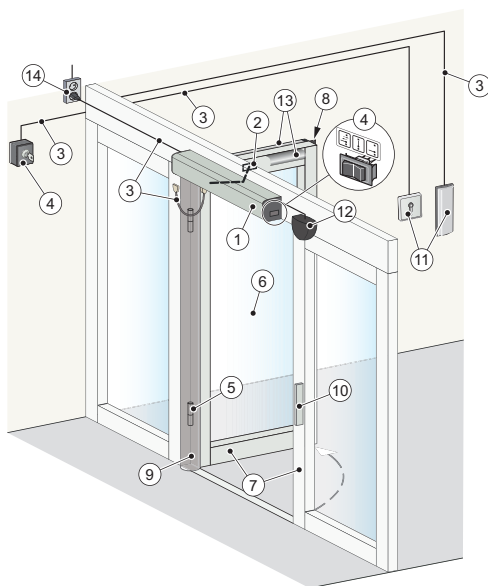

Disconnect the power supply [14] when carrying out cleaning or maintenance tasks.

Activity	In the event of problems
Visually check the conditions of: <ul style="list-style-type: none"> <li>• the automation [1]</li> <li>• arm system [2]</li> <li>• any cables [3] at view</li> <li>• programs selectors [4]</li> <li>• hinges [5]</li> <li>• door wing [6]</li> <li>• any protections for the fingers [9]</li> </ul>	
Put mains power supply [14] to the automation and verify: <ul style="list-style-type: none"> <li>• that the door works correctly.</li> <li>• that the lock (if present) works correctly.</li> </ul>	 
Activate the manual opening commands [11] and check that the door opens correctly during the transit. Proceed with the verification of the automatic opening commands [12].	
Check the intervention of the motion sensors (safety) [13], if present.	



 = adopt suitable measures.  = contact the ENTREMATIC customer service.

## 9. Periodic safety checks to be carried out by qualified personnel

Emergency exit doors	Set the function selector switch to the TWO-WAY mode. Manually push the door in the escape direction and make sure that objects and other obstacles are not hindering the door opening. And make sure that the escape routes are free.	 
Fire barriers	Close the door after pushing it, making sure that there are no obstructions at the closure and at the door locking (if required by the regulations).	 

## 10. Cleaning

To remove dust and dirt from the system, use a soft cloth or sponge.

It can also be used a delicate detergent.

To keep the surface in good condition, clean it at least once every four months.

Do not treat doors and frames with alkaline or abrasive products. they may damage the aluminium and glass.

## 11. General accessories

The automation for swing doors can be equipped with the following accessories:

- Function selector switches.
- Electric lock.
- Key-operated switch.
- Elbow button.
- Opening and safety sensors.
- Movement sensors.
- End stop.
- Badge.
- Digital keypad.

## 12. Troubleshooting

What is the problem?	Solutions
<b>The door does not open</b>	
The motor is not working	Modify the setting of the programs selector. (See paragraphs 6 and 7).
	Check that there are no objects in the detection area, in case a sensor is installed.
	Check the switch and the network fuse in the building.
The motor is working, but the door/the doors does/do not open	Unlock the electric lock.
	Check that there are no objects hindering the normal operation of the door.
<b>The door does not close</b>	
	Modify the setting of the function selector switch. (See paragraphs 6 and 7).
	Check that there are no objects in the detection area, in case a sensor is installed.
	Check that there are no objects hindering the normal operation of the door.
The door opens and closes continuously	Check that there are no moving objects at a distance of 1-1.5 m from the door, in case an opening sensor is installed.

If the problem persists, contact the ENTREMATIC customer Technical Service.

The installation manuals for automations of swing doors are available in:

<http://www.ditecentrematic.it/download>

---

# ENTRE/MATIC



**Entrematic Group AB**  
Lodjursgatan 10  
SE-261 44, Landskrona  
Sweden  
[www.ditecentrematic.com](http://www.ditecentrematic.com)

